

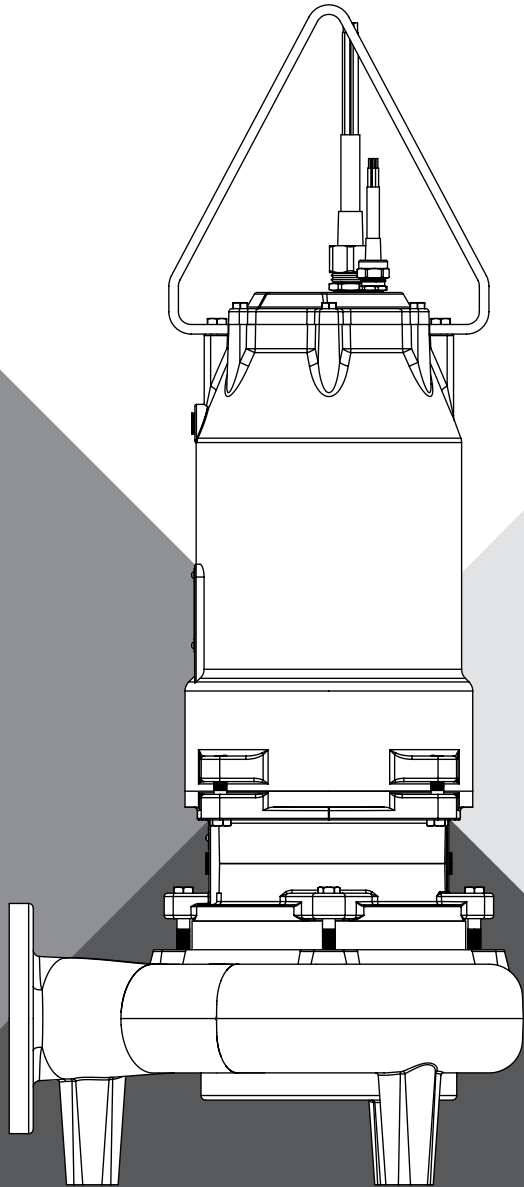

SUBMERSIBLE SOLIDS HANDLING PUMP

C4S(X*)P ♦ H3H(X*)P ♦ H4H(X*)P ♦ S4M(X*)P
S4P(X*)P ♦ S4HV(X*)P ♦ S4MV(X*)P

*Used in Hazardous Locations Class I, Division I, Groups C & D): FM



INSTALLATION AND OPERATION MANUAL

pentair.com

TABLE OF CONTENTS:

SECTION.....	PAGE
General Information.....	3-4
Pump Installation.....	5
Pump Operation & Maintenance	6-7
Parts List.....	8
Hydraulic Ends Part List.....	9
Motor Parts Group	10
Impeller Parts List	10-11
Wiring Diagrams.....	12
Warranty.....	13

GENERAL INFORMATION

READ AND FOLLOW SAFETY INSTRUCTIONS!

 This is the safety alert symbol. When you see this symbol on your pump or in this manual, look for one of the following signal words and be alert to the potential for personal injury:

 **DANGER** warns about hazards that will cause serious personal injury, death or major property damage if ignored.

 **WARNING** warns about hazards that can cause serious personal injury, death or major property damage if ignored.

 **CAUTION** warns about hazards that will or can cause minor personal injury or property damage if ignored.

NOTICE: indicates special instructions which are important but not related to hazards.

- Carefully read and follow all safety instructions in this manual and on pump.
- Keep safety labels in good condition.
- Replace missing or damaged safety labels.
- Make workshops childproof; use padlocks and master switches; remove keys.

 **WARNING** Read carefully the product installation & operation instructions. Failure to follow the instructions and warnings in the manual may result in serious or fatal injury and/or property damage, and will void the product warranty. This product must be installed by a qualified professional. Follow all applicable local and state codes and regulations. In the absence of such codes, follow the current editions of the National Plumbing Code and National Electrical Code (NEC), as applicable.

 **WARNING** This product is used in conjunction with a system containing a tank under pressure, which may over time corrode, weaken and burst or explode, causing serious or fatal personal injury, leaking or flooding and/or property damage. To minimize risk, a licensed professional must install and periodically inspect and service the product and system. A drip pan connected to an adequate drain must be installed if leaking or flooding may cause property damage. Do not locate system in an area where leaking may cause property damage.

 **WARNING** This control is capable of running pumps to pressures that may exceed the limitations of system components. Never set the operating pressure higher than that of the safe system capacity.

 **WARNING** This control can be adjusted to a narrow pressure differential. An improperly sized tank can cause the pump to cycle and lead to pump damage. This may require a larger pressure tank than is normally used.

CALIFORNIA PROPOSITION 65 WARNING

 **WARNING** This product and related accessories contain chemicals known to the State of California to cause cancer, birth defects or other reproductive harm.

ELECTRICAL SAFETY

 **DANGER ELECTROCUTION HAZARD:** Must be installed by a qualified professional. First disconnect all electrical power before attempting service. For your safety, the installation and operation instructions must be followed to minimize the risk of electric shock, property damage or personal injury.

GENERAL SAFETY

 **CAUTION** Do not touch an operating motor. Modern motors can operate at high temperatures. To avoid burns when servicing pump, allow it to cool for 20 minutes after shutdown before handling.

- Do not allow pump or any system component to freeze. To do so will void the warranty. See "Warranty" on Page 10.
- Pump only water with this pump.
- Periodically inspect pump and system components.
- Wear safety glasses at all times when working on pumps.
- Keep work area clean, uncluttered and properly lighted. Store all unused tools and equipment.
- Keep visitors at a safe distance from the work areas.

 **WARNING** Pump body may explode if used as a booster pump unless a relief valve capable of passing full pump flow at 75 psi is installed.

 **WARNING** A water test must be taken before installation of any water treatment equipment. The water quality can significantly influence the life of your system. You should test for corrosive elements, acidity, total solids and other relevant contaminants, including chlorine and treat your water appropriately to ensure satisfactory performance and prevent premature failure.

 **WARNING** Use only lead-free solder and flux for all sweat-solder connections, as required by state and federal codes.

 **WARNING EXPLOSION OR RUPTURE HAZARD:** A relief valve must be installed to prevent pressure in excess of local code requirement or maximum working pressure designated in the product manual, whichever is less. Do not expose system to freezing temperatures or temperatures in excess of 120°F (49°C). Failure to properly size the system or follow instructions in the manual may result in excessive strain on the system and may lead to product failure, leakage, flooding and/or property damage.

GENERAL INFORMATION

This manual contains important information for the safe use of this product. Read completely and do not throw away.

Reasonable care and safe methods should be practiced. Check local codes and requirements before installation.

UNPACKING PUMP

When unpacking unit, check for damage. Claims for damage must be made at the receiving end through the delivery carrier. Damage cannot be processed from the factory.

⚠ WARNING Before handling these pumps and controls, always disconnect the power first. Do not smoke or use sparkable electrical devices or flames in a septic (gaseous) or possible septic sump.

PUMPS IN STORAGE OR NOT OPERATING

Pumps with silicon/carbide seals must have impellers manually rotated (6 revolutions) after setting non-operational for 3 months or longer and prior to electrical start-up.

Pumps with tungsten carbide seals must have impellers manually rotated (6 revolutions) after setting non-operational for 3 weeks or longer and prior to electrical start-up.

SEAL FAILURE PROBES

All hazardous location submersible pumps have two factory installed moisture detectors (seal failure probes). They are in a normally open series circuit in the seal chamber. Under normal operating conditions, the circuit remains open. If the lower seal leaks and moisture enters this chamber, the moisture would settle to the bottom of the chamber and will complete the circuit between the moisture detectors.

This circuit must be connected to a sensing unit and signaling device. This is supplied in a Hydromatic® built control panel. Failure to install such a device negates all warranties by Hydromatic.

HEAT SENSORS

All motors in this family have heat sensors on or embedded in the motor winding to detect excessive heat. This prevents damage to the motor. If sensor trips due to excessive winding temperature,

the starter in the panel breaks power to the pump.

Once the sensor resets, the starter is automatically reset for FM for continued operation of the pump. This circuitry is supplied in a Hydromatic control panel. **The sensors are set to trip at 130°C.** Failure to install such circuitry would negate FM approvals and all warranties by Hydromatic.

POWER CORDS

The power cord and heat sensor seal failure cord are potted into the cord cap. The cords must not be spliced.

Each cable has a green lead. This is the ground wire and must be grounded properly per NEC and/or local codes. Cords should be inspected for abnormal wear and replaced accordingly.

OVERLOAD HEATERS

If the Hydromatic electrical panel is not used, starters with 3 leg overload relay must be supplied on 3 phase pumps. Each leg is to have an identical heater sized in accordance with the nameplate amps on the motor housing. The amp draw on these submersible motors is slightly higher than a corresponding horsepower surface motor, so heaters must be sized by the nameplate rating.

Capacitor start single phase pumps have a run and start winding that draws different currents. To adequately protect these windings with the appropriate heaters, consult the factory.

The red lead is always the start winding of a pump using single phase.

INSTALLING SUMP LEVEL CONTROLS FLOAT CONTROLS

In either simplex, duplex or triplex systems, the lower or turn-off control is to be set to maintain a minimum level in the sump. This level shall be no more than 3-1/4" from the top of the motor housing down to the surface of the sewage.

The second or turn-on control is set above the lower turn-off control. The exact distance between the two floats must be a compromise between a frequent pumping cycle (10 starts per hour max.) to control septicity, solids and a slower cycle for energy economy. This distance should be determined by the engineer or consulting engineer, depending on the conditions of the application.

PUMP INSTALLATION

INSTALLING PUMP IN SUMP

Before installing the pump in the sump, lay it on its side and rotate impeller. Impeller may be slightly stuck due to factory test water. The impeller should turn freely. **DO NOT** connect the power until after this test.

Clean all debris from sump and connect pump to piping. A check valve must be installed on each pump and a gate or plug valve in each pump discharge is highly recommended. This valve should be installed on the discharge side of the check valve so if it becomes necessary to service the check valve, the line pressure can be cut off. Single pump systems are sometimes installed without a check valve where it is desirable to self-drain the discharge line to prevent freezing. This can be done only with short discharge lines; otherwise water will return to the sump and cause short cycling of the pump.

MAKING ELECTRICAL CONNECTIONS

All electrical wiring must be in accordance with local codes, and only competent electricians should make the installations. Complete wiring diagrams are glued to the inside cover of the panel. It is VERY IMPORTANT to check all wires for grounds with an ohmmeter or Megger(r) after the connections are made **as one grounded wire can cause considerable trouble.**

IMPORTANT: If equipment is not properly wired and protected as recommended, the warranty is void.

CAUTION The 230 volt 3 phase pump has a dual marked nameplate. For ordinary location pumps, voltage may be rewired by qualified personnel. For hazardous location pumps, voltage may be rewired by the manufacturer or a Class I, Div I equipment qualified electrician. Once the voltage is changed, the factory cord tag indicating 230 volt 3 phase must be removed.

For record keeping purposes, we suggest the pump be marked externally with the new voltage and qualified personnel that performed the change. Pumps shipped from the factory as 460 volt 3 phase cannot be rewired to any other voltage.

TO RE-WIRE THE PUMP FROM 230V TO 460V 3 PHASE

Only a 230V pump from the factory is considered dual voltage, a cord label clearly states the factory wound voltage.

1. Remove all six (#7) cap screws then raise the cord cap assembly enough to slip a prying instrument on opposite sides between the cord cap casting and the motor housing. Take care to not damage the o-ring or the machined surfaces of the castings. Doing so could void FM agency certifications.
2. While prying evenly on both sides; separate the cord cap casting from the motor housing, the assembly is airtight and will have a vacuum effect when disassembling.
3. Once separated, the cord cap can be inverted and rotated to the outside of the pump assembly, and a bolt can be re-used to secure the upside down cord cap to the motor housing for ease of rewiring.

Refer to the wiring diagram within this manual for wiring details. Once all electrical connections are finished and secure (a crimped electrical connector is best to prevent issues due to vibration if required), the cord cap should be re-attached reversing the steps above. Ensure the o-ring is in place and perform a hi-pot test for safety once everything is complete.

HEAT SENSORS AND SEAL FAILURE CONNECTIONS

Be sure heat sensor wires are connected in series with the starter coil. Connections are provided on the terminal strip.

NUMBER OF CONDUCTORS REQUIRED BETWEEN CONTROL PANEL AND NEMA 4 JUNCTION BOX

Power lines and control wires can be carried in conduit or can be underground buried cable

System Type	Number of Control Wire	Number of Power Line	Number of Ground Wires #8	Heat Sensor & Seal Failure	
				Number of Sensor Wires	Number of Ground Wires
Simplex	4	3	1	3	1
Simplex with Alarm	6	3	1	3	1
Duplex	6	6	2	6	2
Duplex with Alarm	8	6	2	6	2

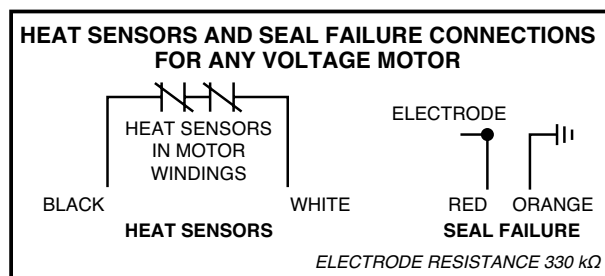
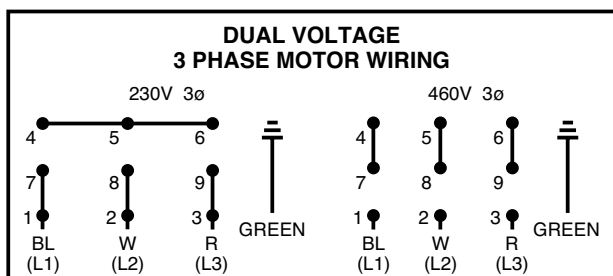

PUMP OPERATIONS & MAINTENANCE

PUMP OPERATIONS STARTING SYSTEM

1. Double check all wire connections.
2. Turn pumps to Off position on H-O-A switches.
3. Turn on breakers.
4. When using single phase pumps, make sure red pump lead is connected to capacitor circuit. Connect amprobe to pump power cord and turn pump on. The pump will show high amp draw momentarily, then as pump comes off start wirings, amps will drop to normal nameplate amps.
5. When using three phase pumps (230/460/575), turn the H-O-A switch to Hand position on one pump and notice operation. If pump is noisy and vibrates, rotation is wrong. To change rotation, interchange any two line leads to pump. Do not interchange main incoming lines. Check rotation of all pumps in this same manner.
6. Now set both H-O-A switches to Auto position and allow water to rise in sump until one pump starts. Allow pump to operate until the level drops to turn-off point.
7. Allow sump level to rise to start other pump(s). Notice run lights in panel. Pumps should alternate on each successive cycle of operation.
8. Turn both H-O-A switches to Off position and allow sump to fill to the override control level(s).
9. Turn switches to Auto position, and pumps should start and operate together until level drops to turn-off point.
10. Repeat this operation and cycle several times before leaving the job.
11. Check voltage when pumps are operating and check the amp draw of each pump. Check amps on each wire as sometimes a high leg will exist. For excessive voltage on one leg, the electric utility company should be consulted.

PUMP MAINTENANCE

As the motors are oil filled, no lubrication or other maintenance is required.

If the heat sensor and seal failure are hooked up properly, no attention is necessary as long as the seal failure indicator light does not come on. To ensure continuity of the seal sensor leads, a test light is provided on intrinsically safe Hydromatic panels as standard equipment.

Pump should be checked every quarter for corrosion and wear.

▲ WARNING Before handling these pumps and controls, always disconnect the power first. Do not smoke, use flames or devices that can produce electrical discharge or sparks in a septic (gaseous) or possible septic sump.

FIELD SERVICE ON HYDROMATIC ORDINARY LOCATION PUMPS

Ordinary location submersible motors that are out of warranty can be serviced in the field by any reliable motor service shop.

Any pump that is in warranty must be returned to the factory for service or repaired at an authorized Pentair Hydromatic service center. Charges will not be allowed if (in warranty) pump is not taken to an authorized Pentair Hydromatic service center. When field service is performed on a pump, these instructions should be carefully followed.

FIELD SERVICE ON HYDROMATIC HAZARDOUS LOCATION PUMPS

Hydromatic hazardous location pumps must be returned to the factory for electrical and motor service. Any repair not at an authorized service center will void the Factory Mutual (FM) listing. This will ensure the integrity of the hazardous location rating of the pump and comply with our warranty requirements.

The quick disconnect cords, upper and lower seal, volute and impeller components may be repaired or replaced by an authorized Hydromatic service facility without compromising the hazardous location rating to the pump.

Any time a seal is disturbed, it must be replaced.

Check the pump for proper rotation before returning to service.

ADJUST CUTTER CLEARANCE ON CHOPPER PUMP

▲ WARNING Disconnect power before adjusting chopper clearance; always keep fingers and hands away from chopper parts.

1. First install the chopper plate (Item D) into the volute. It may be helpful to install 1/2-20 studs into the chopper plate to line up the holes with the corresponding volute holes. You may have to tap the plate all the way down with a rubber hammer.
2. Remove the studs and replace with four 1/2-20 x 1 (Item A) in long socket head screws from beneath the volute, do not tighten.
3. Install motor with impeller mounted, tighten motor housing bolts to the volute
4. Install the chopper retainer ring (Item B) and tighten the four 3/8 -16 x 1" long (Item C) socket head cap screws to force the chopper plate up against the impeller and chopper blade
5. Next back off these 3/8-16 (Item C) bolts one quarter of a turn. This should give you .015 clearances.
6. Tighten the outer four 1/2 -20 screws (Item A) to 75-85 Ft-lbs.
7. Measure the clearance with a feeler gage it should be between .010 and .015.
8. Spin impeller with a hex wrench on the Impeller hub screw or use a wooden pry bar to spin impeller to make sure there is no rub.
9. If you hear or feel a rub readjust the clearance by loosening the inner 3/8-16" screws evenly and tightening the 1/2-20 screws.

TROUBLESHOOTING

Pump Troubleshooting

Below is a list of common problems and the probable causes:
Pump will not start.

1. No power to the motor. Check for blown fuse or open circuit breaker.
2. Selector switch may be in the Off position.
3. Control circuit transformer fuse may be blown.
4. Overload heater on starter may be tripped. Push to reset.

Pump will not start and overload heaters trip.

1. Turn off power and check motor leads with Megger or ohmmeter for possible ground.
2. Check resistance of motor windings. All 3 phases should show the same reading.
3. If no grounds exist and the motor windings check OK, remove pump from sump and check for clogged or blocked impeller.

Pump operates with selector switch in Hand position but will not operate in Auto position.

1. This indicates trouble in the float level control or the alternator relay.
2. Check control panel for trouble.

Pump runs but will not shut off.

1. Pump may be air locked. Turn pump off and let set for several minutes, then restart.
2. Lower float control may be hung-up in the closed position. Check in sump to be sure control is free.
3. Selector switch may be in the Hand position.

Pump does not deliver proper capacity.

1. Discharge gate valve may be partially closed or partially clogged.
2. Check valve may be partially clogged. Raise level up and down to clear.
3. Pump may be running in wrong direction. Low speed pumps can operate in reverse direction without much noise or vibration.
4. Discharge head may be too high. Check total head with gauge when pump is operating. Total head is discharge gauge pressure converted to feet plus vertical height from water level in sump to center line of pressure gauge in discharge line. Gauge should be installed on pump side of all valves. Multiply gauge pressure in pounds by 2.31 to get head in feet.
5. If pump has been in service for some time and capacity falls off, remove pump and check for wear or clogged impeller.

Motor stops and then restarts after short period but overload heaters in starter do not trip.

1. This indicates heat sensors in the motor are tripping due to excessive heat. Impeller may be partially clogged giving a sustained overload but not high enough to trip overload heater switch.
2. Motor may be operating out of liquid due to a failed level control.
3. Pump may be operating on a short cycle due to sump being too small or from water returning to sump due to a leaking check valve.

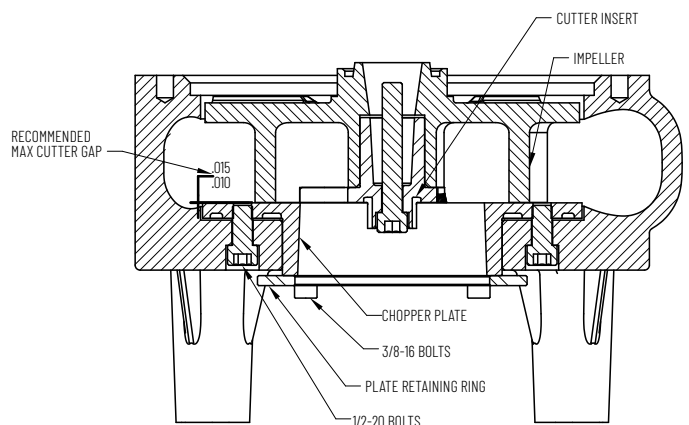
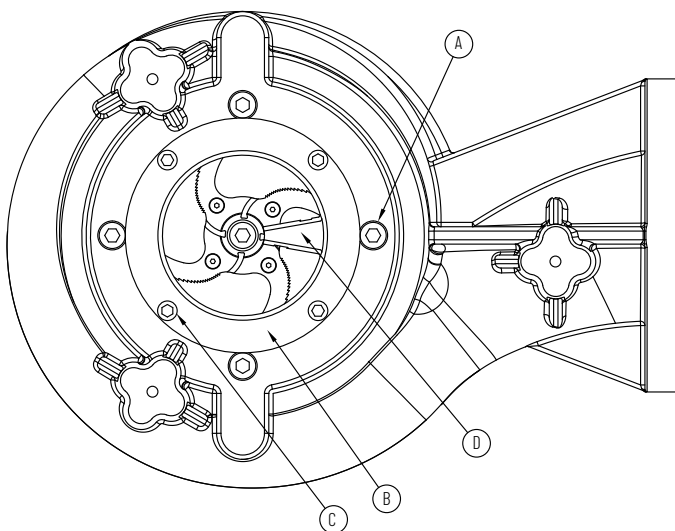

PUMP PARTS LIST

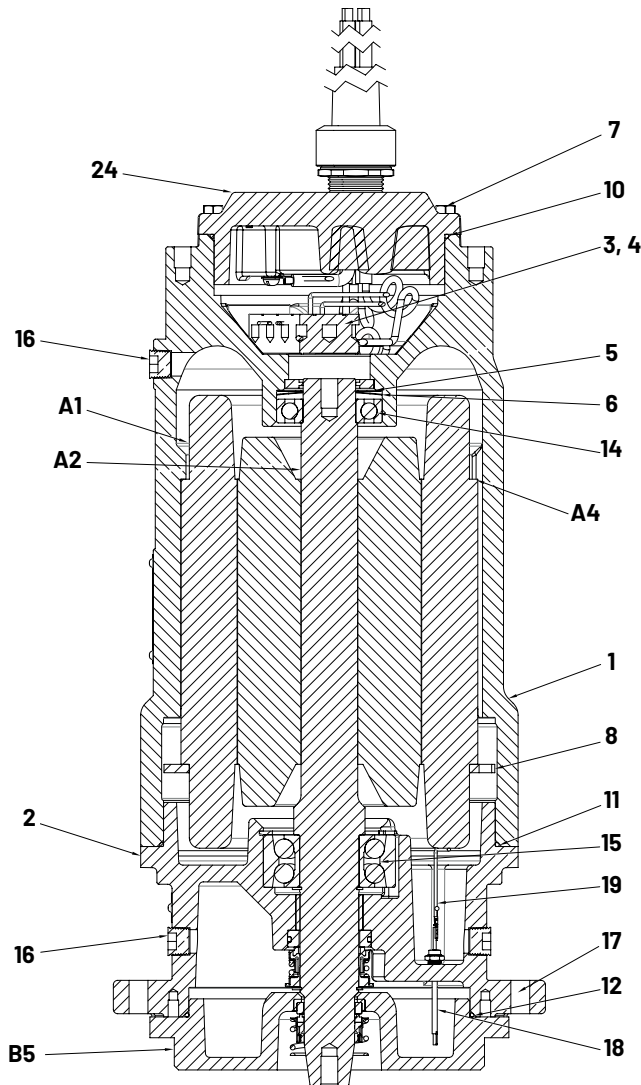

C4S(X)P, H3H(X)P, H4H(X)P, S4M(X)P, S4P(X)P, S4HV(X)P and S4MV(X)P

For use with product built with Premium Efficient motor.

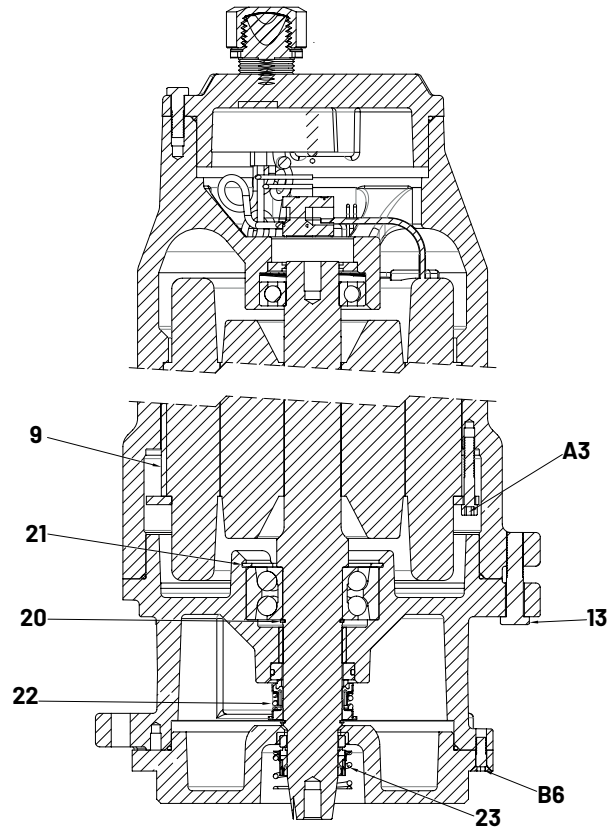

Ref.No.	Part No.	Part Description	Qty.
1	28010D000	MOTOR HOUSING	1
2	27818D010	BEARING HOUSING	1
3	27882A009	TERMINAL BLOCK	1
4	06106A069	SCREW(TERMINAL BLOCK)	2
5	110650033	SCREEN	1
6	19331A007	WASHER SPRING(THRUST)	1
7	19101A017	CAP SCREW(CORD CAP)	6
8	026032103	STATOR RING	1
9	05818A090	KEY S0. 5/32	1
10	001500191	O-RING(CORD CAP)	1
11	05876A135	O-RING(MOTOR HOUSING)	1
12	05876A121	O-RING(SEAL PLATE)	1
13	19103A048	SCREW CAP 1/2-13 x 2.5 LG	4
14	000650111	BALL BEARING UPPER	1
15	071670181	DOUBLE ROW BALL BEARING LOWER	1
16	009240101	PIPE PLUG 1/2 SOCKET HEAD BRASS	3

Ref.No.	Part No.	Part Description	Qty.
17	19103A048	CAPSCREW - S4M(X)P, S4MV(X)P, S4HV(X)P	4
	19103A060	CAPSCREW - S4P(X)P, H3H(X)P, H4H(X)P, C4S(X)P	4
18	109010011	SEAL FAILURE PROBE	2
19	109000025	SENSOR WIRES	1
20	12558A017	RETAINING RING EXTERNAL	1
21	009740031	RETAINING RING INTERNAL	1
22	110491001	UPPER SEAL	1
23	009201001	LOWER SEAL	1
	152880315	CORD CAP ASSEMBLY - 10-4 S00W	1
	152880325	CORD CAP ASSEMBLY - 8-4 W	1
24	152880335	CORD CAP ASSEMBLY - 6-4 W	1
	278190003	SEAL PLATE - S4M(X)P, S4MV(X)P, S4HV(X)P	1
B5	278190103	SEAL PLATE- S4P(X)P, H3H(X)P, H4H(X)P, C4S(X)P	1
B6	07597A017	BOLT(SEAL PLATE) S4M(X)P, S4MV(X)P, S4HV(X)P	4
	047560061	BOLT(SEAL PLATE) S4P(X)P, H3H(X)P, H4H(X)P, C4S(X)P	4

HYDRAULIC ENDS PART LIST

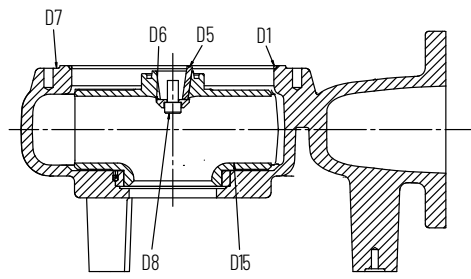

S4M(X)P

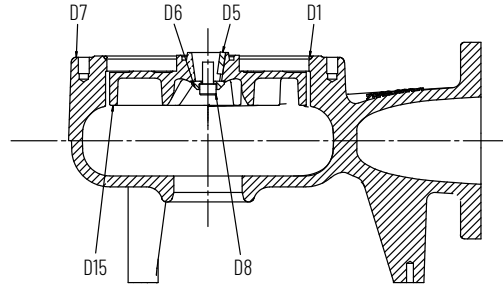

S4MV(X)P

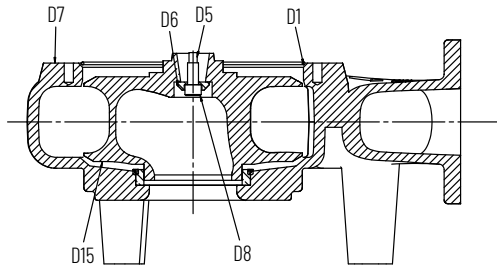

S4P(X)P

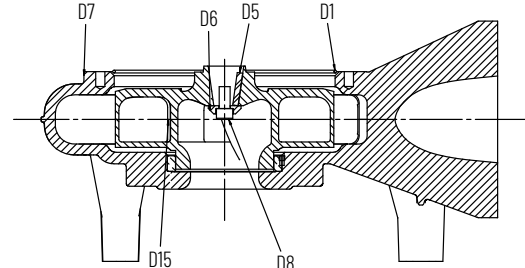

H3H(X)P

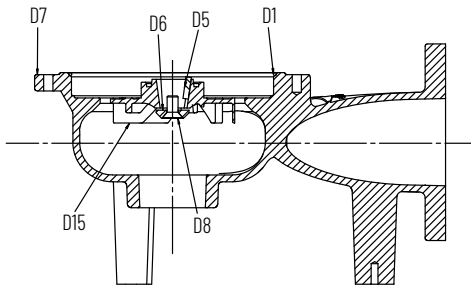

S4HV(X)P

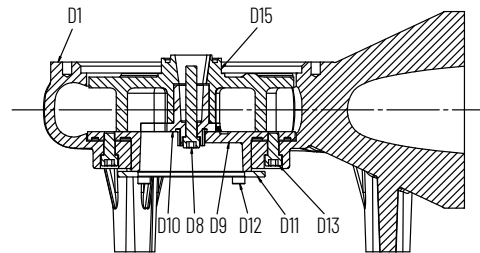

C4S(X)P

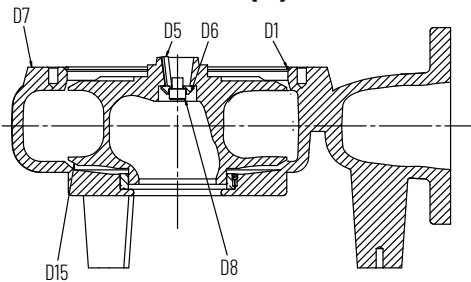

H4H(X)P

Item No.	Description	S4M(X)P	S4MV(X)P	S4HV(X)P	S4P(X)P	H3H(X)P	H4H(X)P	C4S(X)P
D1	O-RING	001500581	001500581	001500581	05876A136	05876A136	05876A136	05876A136
D5	IMPELLER KEY	083460033	083460011	083460011	083460033	083460033	083460033	083460033
D6	WASHER - IMPELLER	080230001	080230001	080230011	080230001	080230001	080230001	N/A
D7	VOLUTE	070680015	070800002	0082120002	137210015	151540015	151470015	153300002
D8	IMP BOLT	005680021	005680021	029210041	005680021	005680021	005680021	005680191
D9	CHOPPER PLATE	N/A	N/A	N/A	N/A	N/A	N/A	153340002
D10	CHOPPER BLADE	N/A	N/A	N/A	N/A	N/A	N/A	153320002
D11	RETAINER PLATE	N/A	N/A	N/A	N/A	N/A	N/A	153330001
D12	SCREW-CAP (RETAINER)	N/A	N/A	N/A	N/A	N/A	N/A	06106A028
D13	SCREW-CAP (CHOPPER PLATE)	N/A	N/A	N/A	N/A	N/A	N/A	005680021
D14	SCREW - FLAT HEAD SOCKET	N/A	N/A	N/A	N/A	N/A	N/A	07597A037
D15	IMPELLER	070710012	070810002	0082130052	137220012	151465002	151465002	153310002

MOTOR PARTS GROUP

Item	2-Pole 3450 RPM	10 - 15 hp 208-230/3/60	10 - 15 hp 460/3/60	10 - 15 hp 575/3/60	7.5 hp 208-230/3/60	7.5 hp 460/3/60	7.5 hp 575/3/60
A1	STATOR	27889D003	27889D003	27889D603	27887D003	27887D003	27887D603
A2	ROTOR/SHAFT ASSEMBLY	27887D011	27887D011	27887D011	27887D011	27887D011	27887D011
A3	BOLT - STATOR(4)	001780051	001780051	001780051	001780051	001780051	001780051
A4	SPACER	007362141	007362141	007362141	007362141	007362141	007362141
	CONNECTOR	-	12672A001	-	-	12672A001	-

Item	4-Pole 1750 RPM	10 - 15 hp 208-230/3/60	10 - 15 hp 460/3/60	10 - 15 hp 575/3/60	5 - 7.5 hp 208-230/1/60	5 - 7.5 hp 208-230/3/60	5 - 7.5 hp 460/3/60	5 - 7.5 hp 575/3/60
A1	STATOR	27886D003	27886D003	27886D603	27885D001	27884D003	27884D003	27884D603
A2	ROTOR/SHAFT ASSEMBLY	27886D011	27886D011	27886D011	27885D011	27884D011	27884D011	27884D011
A3	BOLT - STATOR(4)	06106A070	06106A070	06106A070	001780051	001780041	001780041	001780041
A4	SPACER	-	-	-	007362141	007362141	007362141	007362141
	CONNECTOR	-	12672A001	-	-	-	12672A001	-

Item	6-Pole 1150 RPM	3 - 5 hp 208-230/3/60	3 - 5 hp 460/3/60	3 - 5 hp 575/3/60
A1	STATOR	27883D003	27883D003	27883D603
A2	ROTOR/SHAFT ASSEMBLY	27883D011	27883D011	27883D011
A3	BOLT - STATOR(4)	001780051	001780051	001780051
A4	SPACER	007362141	007362141	007362141
	CONNECTOR	-	12672A001	-

IMPELLER PARTS LIST

H3H(X)P

Description	HP	Voltage/PH	Cord	Trim	Impeller
1750 RPM					
H3H(X)P500BC	5	208/1	8-4	7.50	151465102
H3H(X)P500CC	5	230/1	8-4	7.50	151465102
H3H(X)P500DC	5	208/3	10-4	7.50	151465102
H3H(X)P500EC	5	230/3	10-4	7.50	151465102
H3H(X)P500FC	5	460/3	10-4	7.50	151465102
H3H(X)P500GC	5	575/3	10-4	7.50	151465102
H3H(X)P750CC	7.5	230/1	8-4	8.00	151465082
H3H(X)P750DC	7.5	208/3	8-4	8.00	151465082
H3H(X)P750EC	7.5	230/3	8-4	8.00	151465082
H3H(X)P750FC	7.5	460/3	10-4	8.00	151465082
H3H(X)P750GC	7.5	575/3	10-4	8.00	151465082
H3H(X)P1000DC	10	208/3	8-4	8.50	151465062
H3H(X)P1000EC	10	230/3	8-4	8.50	151465062
H3H(X)P1000FC	10	460/3	10-4	8.50	151465062
H3H(X)P1000GC	10	575/3	10-4	8.50	151465062
H3H(X)P1500DC	15	208/3	8-4	10.00	151465002
H3H(X)P1500EC	15	230/3	8-4	10.00	151465002
H3H(X)P1500FC	15	460/3	8-4	10.00	151465002
H3H(X)P1500GC	15	575/3	10-4	10.00	151465002

H4H(X)P

Description	HP	Voltage/PH	Cord	Trim	Impeller
1750 RPM					
H4H(X)P500BC	5	208/1	8-4	7.50	151465102
H4H(X)P500CC	5	230/1	8-4	7.50	151465102
H4H(X)P500DC	5	208/3	10-4	7.50	151465102
H4H(X)P500EC	5	230/3	10-4	7.50	151465102
H4H(X)P500FC	5	460/3	10-4	7.50	151465102
H4H(X)P500GC	5	575/3	10-4	7.50	151465102
H4H(X)P750CC	7.5	230/1	8-4	8.00	151465082
H4H(X)P750DC	7.5	208/3	8-4	8.00	151465082
H4H(X)P750EC	7.5	230/3	8-4	8.00	151465082
H4H(X)P750FC	7.5	460/3	10-4	8.00	151465082
H4H(X)P750GC	7.5	575/3	10-4	8.00	151465082
H4H(X)P1000DC	10	208/3	8-4	8.63	151465142
H4H(X)P1000EC	10	230/3	8-4	8.63	151465142
H4H(X)P1000FC	10	460/3	10-4	8.63	151465142
H4H(X)P1000GC	10	575/3	10-4	8.63	151465142
H4H(X)P1500DC	15	208/3	8-4	9.50	151465022
H4H(X)P1500EC	15	230/3	8-4	9.50	151465022
H4H(X)P1500FC	15	460/3	8-4	9.50	151465022
H4H(X)P1500GC	15	575/3	10-4	9.50	151465022

IMPELLER PARTS LIST

S4M(X)P

Description	HP	Voltage/PH	Cord	Trim	Impeller
1750 RPM					
S4M(X)P500BC	5	208/1	8-4	6.75	070710312
S4M(X)P500CC	5	230/1	8-4	6.75	070710312
S4M(X)P500DC	5	208/3	10-4	6.75	070710312
S4M(X)P500EC	5	230/3	10-4	6.75	070710312
S4M(X)P500FC	5	460/3	10-4	6.75	070710312
S4M(X)P500GC	5	575/3	10-4	6.75	070710312
S4M(X)P750CC	7.5	230/1	8-4	7.63	070710442
S4M(X)P750DC	7.5	208/3	8-4	7.63	070710442
S4M(X)P750EC	7.5	230/3	8-4	7.63	070710442
S4M(X)P750FC	7.5	460/3	10-4	7.63	070710442
S4M(X)P750GC	7.5	575/3	10-4	7.63	070710442
S4M(X)P1000DC	10	208/3	8-4	8.13	070710202
S4M(X)P1000EC	10	230/3	8-4	8.13	070710202
S4M(X)P1000FC	10	460/3	10-4	8.13	070710202
S4M(X)P1000GC	10	575/3	10-4	8.13	070710202
S4M(X)P1500DC	15	208/3	8-4	8.63	070710172
S4M(X)P1500EC	15	230/3	8-4	8.63	070710172
S4M(X)P1500FC	15	460/3	8-4	8.63	070710172
S4M(X)P1500GC	15	575/3	10-4	8.63	070710172
1150 RPM					
S4M(X)P300DB	3	208/3	10-4	7.75	070710062
S4M(X)P300EB	3	230/3	10-4	7.75	070710062
S4M(X)P300FB	3	460/3	10-4	7.75	070710062
S4M(X)P300GB	3	575/3	10-4	7.75	070710062
S4M(X)P500DB	5	208/3	10-4	8.75	070710022
S4M(X)P500EB	5	230/3	10-4	8.75	070710022
S4M(X)P500FB	5	460/3	10-4	8.75	070710022
S4M(X)P500GB	5	575/3	10-4	8.75	070710022

S4MV(X)P

Description	HP	Voltage/PH	Cord	Trim	Impeller
1750 RPM					
S4MV(X)P500BC	5	208/1	8-4	6.5	070810332
S4MV(X)P500CC	5	230/1	8-4	6.5	070810332
S4MV(X)P500DC	5	208/3	10-4	6.5	070810332
S4MV(X)P500EC	5	230/3	10-4	6.5	070810332
S4MV(X)P500FC	5	460/3	10-4	6.5	070810332
S4MV(X)P500GC	5	575/3	10-4	6.5	070810332
S4MV(X)P750CC	7.5	230/1	8-4	7.38	070810072
S4MV(X)P750DC	7.5	208/3	8-4	7.38	070810072
S4MV(X)P750EC	7.5	230/3	8-4	7.38	070810072
S4MV(X)P750FC	7.5	460/3	10-4	7.38	070810072
S4MV(X)P750GC	7.5	575/3	10-4	7.38	070810072
S4MV(X)P1000DC	10	208/3	8-4	8	070810022
S4MV(X)P1000EC	10	230/3	8-4	8	070810022
S4MV(X)P1000FC	10	460/3	10-4	8	070810022
S4MV(X)P1000GC	10	575/3	10-4	8	070810022
S4MV(X)P1500DC	15	208/3	8-4	8.75	070810092
S4MV(X)P1500EC	15	230/3	8-4	8.75	070810092
S4MV(X)P1500FC	15	460/3	8-4	8.75	070810092
S4MV(X)P1500GC	15	575/3	10-4	8.75	070810092
1150 RPM					
S4MV(X)P300DB	3	208/3	10-4	7.75	070810102
S4MV(X)P300EB	3	230/3	10-4	7.75	070810102
S4MV(X)P300FB	3	460/3	10-4	7.75	070810102
S4MV(X)P300GB	3	575/3	10-4	7.75	070810102
S4MV(X)P500DB	5	208/3	10-4	8.75	070810092
S4MV(X)P500EB	5	230/3	10-4	8.75	070810092
S4MV(X)P500FB	5	460/3	10-4	8.75	070810092
S4MV(X)P500GB	5	575/3	10-4	8.75	070810092

S4HV(X)P

Description	HP	Voltage/PH	Cord	Trim	Impeller
3450 RPM					
S4HV(X)P750DD	7.5	208/3	8-4	4.63	082130172
S4HV(X)P750ED	7.5	230/3	8-4	4.63	082130172
S4HV(X)P750FD	7.5	460/3	10-4	4.63	082130172
S4HV(X)P750GD	7.5	575/3	10-4	4.63	082130172
S4HV(X)P1000DD	10	208/3	8-4	5	082130042
S4HV(X)P1000ED	10	230/3	8-4	5	082130042
S4HV(X)P1000FD	10	460/3	10-4	5	082130042
S4HV(X)P1000GD	10	575/3	10-4	5	082130042

S4P(X)P

Description	HP	Voltage/PH	Cord	Trim	Impeller
1750 RPM					
S4P(X)P500BC	5	208/1	8-4	6.5	137226152
S4P(X)P500CC	5	230/1	8-4	6.5	137226152
S4P(X)P500DC	5	208/3	10-4	6.5	137226152
S4P(X)P500EC	5	230/3	10-4	6.5	137226152
S4P(X)P500FC	5	460/3	10-4	6.5	137226152
S4P(X)P500GC	5	575/3	10-4	6.5	137226152
S4P(X)P750CC	7.5	230/1	8-4	7.75	137226102
S4P(X)P750DC	7.5	208/3	8-4	7.75	137226102
S4P(X)P750EC	7.5	230/3	8-4	7.75	137226102
S4P(X)P750FC	7.5	460/3	10-4	7.75	137226102
S4P(X)P750GC	7.5	575/3	10-4	7.75	137226102
S4P(X)P1000DC	10	208/3	8-4	8.63	137226162
S4P(X)P1000EC	10	230/3	8-4	8.63	137226162
S4P(X)P1000FC	10	460/3	10-4	8.63	137226162
S4P(X)P1000GC	10	575/3	10-4	8.63	137226162
S4P(X)P1500DC	15	208/3	8-4	9.63	137226182
S4P(X)P1500EC	15	230/3	8-4	9.63	137226182
S4P(X)P1500FC	15	460/3	8-4	9.63	137226182
S4P(X)P1500GC	15	575/3	10-4	9.63	137226182

C4S(X)P

Description	HP	Voltage/PH	Cord	Trim	Impeller
1750 RPM					
C4S(X)P750CC	7.5	230/1	8-4	7	153310192
C4S(X)P750DC	7.5	208/3	8-4	7	153310192
C4S(X)P750EC	7.5	230/3	8-4	7	153310192
C4S(X)P750FC	7.5	460/3	10-4	7	153310192
C4S(X)P750GC	7.5	575/3	10-4	7	153310192
C4S(X)P1000DC	10	208/3	8-4	7	153310192
C4S(X)P1000EC	10	230/3	8-4	7	153310192
C4S(X)P1000FC	10	460/3	10-4	7	153310192
C4S(X)P1000GC	10	575/3	10-4	7	153310192
C4S(X)P1500DC	15	208/3	8-4	8.5	153310072
C4S(X)P1500EC	15	230/3	8-4	8.5	153310072
C4S(X)P1500FC	15	460/3	8-4	8.5	153310072
C4S(X)P1500GC	15	575/3	10-4	8.5	153310072
1150 RPM					
C4S(X)P300DB	3	208/3	10-4	7.25	153310172
C4S(X)P300EB	3	230/3	10-4	7.25	153310172
C4S(X)P300FB	3	460/3	10-4	7.25	153310172
C4S(X)P300GB	3	575/3	10-4	7.25	153310172
C4S(X)P500DB	5	208/3	10-4	8.88	153310122
C4S(X)P500EB	5	230/3	10-4	8.88	153310122
C4S(X)P500FB	5	460/3	10-4	8.88	153310122
C4S(X)P500GB	5	575/3	10-4	8.88	153310122

WIRING DIAGRAMS

1 PHASE

BLACK, WHITE, AND RED MOTOR LEADS CAN ONLY BE CONNECTED TO PANEL TERMINAL BLOCKS AS SHOWN ON SCHEMATIC. INCORRECT CONNECTION CAN CAUSE DAMAGE TO PUMP AND/OR PANEL COMPONENTS. THREE PHASE OVERLOAD RELAY MUST BE CLASS 10 TRIP & AMBIENT COMPENSATED & CONNECTED IN THE "DAISY CHAIN" CIRCUIT AS SHOWN.

Notes:

1. Level Switches Must be Rated a Minimum of 2 Amps at 120 Volts
2. Torque all white field wiring terminals to 20 in. Lbs.
3. Field Wiring Must be 60°C Copper Wire Minimum.
4. ----- = Items Note Supplied In Control Panel.
5. Pump power, heat sensor, and seal probe cables must pass through approved NEC 501.15 conduit seals.

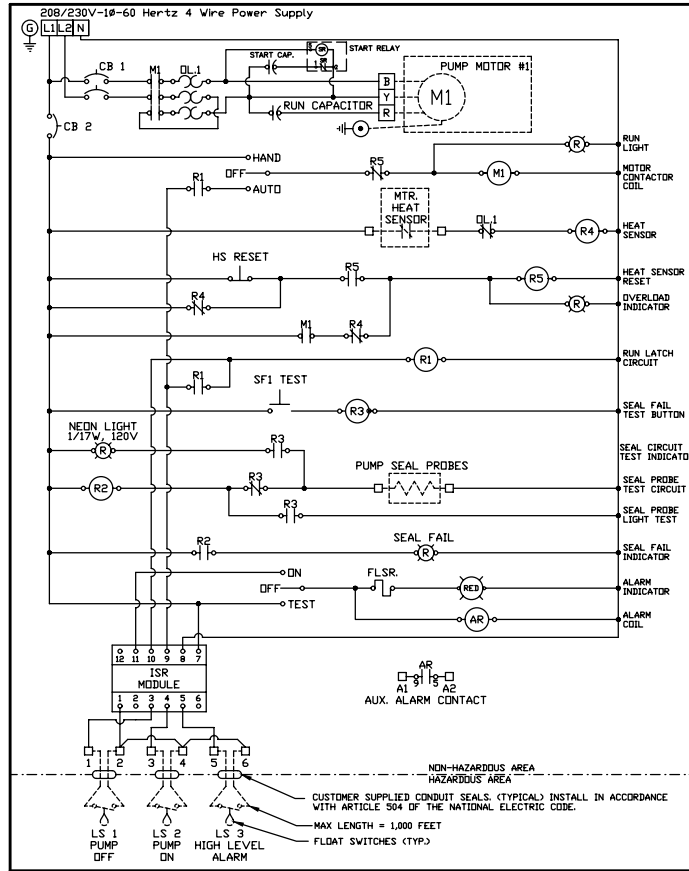

3 PHASE

Notes:

1. Level Switches Must be Rated a Minimum of 2 Amps at 120 Volts
2. Torque all white field wiring terminals to 20 in. Lbs.
3. Field Wiring Must be 60°C Copper Wire Minimum.
4. ----- = Items Note Supplied In Control Panel.
5. Pump power, heat sensor, and seal probe cables must pass through approved NEC 501.15 conduit seals.

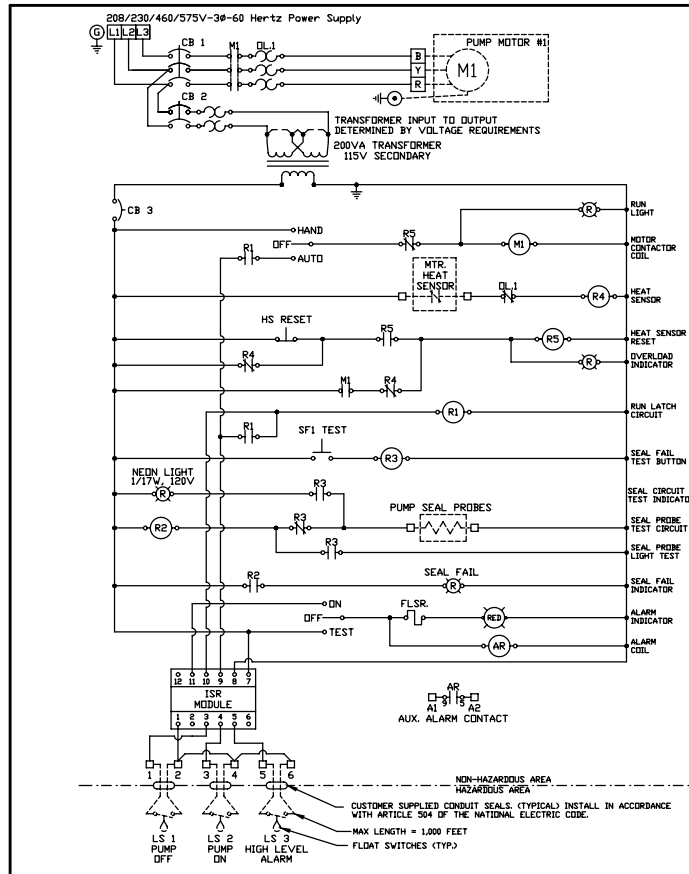

WARRANTY

Pentair Hydromatic® warrants its products against defects in material and workmanship for a period of 12 months from installation date or 18 months from manufacturing date, whichever occurs first – provided that such products are used in compliance with the requirements of the Pentair Hydromatic catalog and technical manuals for use in pumping raw sewage, municipal wastewater or similar, abrasive-free, noncorrosive liquids.

During the warranty period and subject to the conditions set forth, Pentair Hydromatic, at its discretion, will repair or replace to the original user, the parts that prove defective in materials and workmanship. Pentair Hydromatic reserves the right to change or improve its products or any portions thereof without being obligated to provide such a change or improvement for prior sold and/or shipped units.

Start-up reports and electrical schematics may be required to support warranty claims. Submit at the time of start up through the Pentair Hydromatic website: <http://forms.pentairliterature.com/startupform/startupform.asp?type=h>. Warranty is effective only if Pentair Hydromatic authorized control panels are used. All seal fail and heat sensing devices must be hooked up, functional and monitored or this warranty will be void. Pentair Hydromatic will cover only the lower seal and labor thereof for all dual seal pumps. Under no circumstance will Pentair Hydromatic be responsible for the cost of field labor, travel expenses, rented equipment, removal/reinstallation costs or freight expenses to and from the factory or an authorized Pentair Hydromatic service facility.

This limited warranty will not apply: (a) to defects or malfunctions resulting from failure to properly install, operate or maintain the unit in accordance with the printed instructions provided; (b) to failures resulting from abuse, accident or negligence; (c) to normal maintenance services and parts used in connection with such service; (d) to units that are not installed in accordance with applicable local codes, ordinances and good trade practices; (e) if the unit is moved from its original installation location; (f) if unit is used for purposes other than for what it is designed and manufactured; (g) to any unit that has been repaired or altered by anyone other than Pentair Hydromatic or an authorized Pentair Hydromatic service provider; (h) to any unit that has been repaired using non factory specified/OEM parts.

Warranty Exclusions: PENTAIR HYDROMATIC MAKES NO EXPRESS OR IMPLIED WARRANTIES THAT EXTEND BEYOND THE DESCRIPTION ON THE FACE HEREOF. PENTAIR HYDROMATIC SPECIFICALLY DISCLAIMS THE IMPLIED WARRANTIES OF MERCHANTABILITY AND FITNESS FOR ANY PARTICULAR PURPOSE.

Liability Limitation: IN NO EVENT SHALL PENTAIR HYDROMATIC BE LIABLE OR RESPONSIBLE FOR CONSEQUENTIAL, INCIDENTAL OR SPECIAL DAMAGES RESULTING FROM OR RELATED IN ANY MANNER TO ANY PENTAIR HYDROMATIC PRODUCT OR PARTS THEREOF. PERSONAL INJURY AND/OR PROPERTY DAMAGE MAY RESULT FROM IMPROPER INSTALLATION. PENTAIR HYDROMATIC DISCLAIMS ALL

LIABILITY, INCLUDING LIABILITY UNDER THIS WARRANTY, FOR IMPROPER INSTALLATION. PENTAIR HYDROMATIC RECOMMENDS INSTALLATION BY PROFESSIONALS.

Some states do not permit some or all of the above warranty limitations or the exclusion or limitation of incidental or consequential damages and therefore such limitations may not apply to you. No warranties or representations at any time made by any representatives of Pentair Hydromatic shall vary or expand the provision hereof.

NOTES

NOTES



1101 Myers Parkway | Ashland, OH 44805 | Ph: 855-274-8947 | Orders Fax: 419-281-4087 | pentair.com/hydromatic

For a detailed list of where Pentair trademarks are registered, please visit www.pentair.com/en/registrations.html. Pentair trademarks and logos are owned by Pentair PLC, or its affiliates. Third party registered and unregistered trademarks and logos are the property of their respective owners. Because we are continuously improving our products and services, Pentair reserves the right to change specifications without prior notice. Pentair is an equal opportunity employer.

E-03-557(01-23-20) ©2020 Pentair. All Rights Reserved.