



DELTA ENVIRONMENTAL[®]
D1P20-21 SERIES
RETROFIT SYSTEMS

DELTA ENVIRONMENTAL[®]

Retrofit Systems

Delta Environmental's progressing cavity retrofit systems solve the problems most common to other grinder systems. Delta Environmental's low-pressure sewage replacement grinder pumps:

- Eliminate controls in wet wells
- Eliminate broken sensing bells
- Eliminate plugged breathers

Delta Environmental's Retrofit Systems Offer the Industry's Most Trouble-Free Grinder Service and are Easy to Install.

- Engineered to fit into existing progressing cavity grinder systems
- One-piece assembly
- Reliable semi-positive displacement Delta Environmental D1P20-21 pumps are UL 778 rated for submersible operation
- Lift out existing system and drop the new Delta Environmental pump into the existing basin
- Change over takes just minutes to complete
- Connects simply to existing wiring and control box
- No electronic controls in the wet well
- Standard SST discharge piping
- Brass anti-siphon valve
- Low operation and maintenance costs
- Mercury-free high-water alarm float initiates redundant pump run
- Injection molded control box sub door is non-conductive



basin not included

Quick Connection Plug

With the availability of a reliable Quick Connection Plug, Delta Environmental eliminates the hassle of cutting and hard wiring the pump system to the existing control box and helps the installer with a safe and quick connection.



Note: The Quick Connection Plug is only available for Delta Environmental's Pressure Control Systems

Retrofit System Details

Retrofit Systems:

Model: D1P20-21PCP (Shown)

- State of the art pressure control system with built-in protection against loss of pressure.

Model: D1P20-21PCF

- Float system provides accurate On/Off/Alarm liquid level control in sewage environments.

Aftermarket Retrofit Kit:

Model: D1P20-21 AMPD

- Semi-positive displacement aftermarket replacement pump.

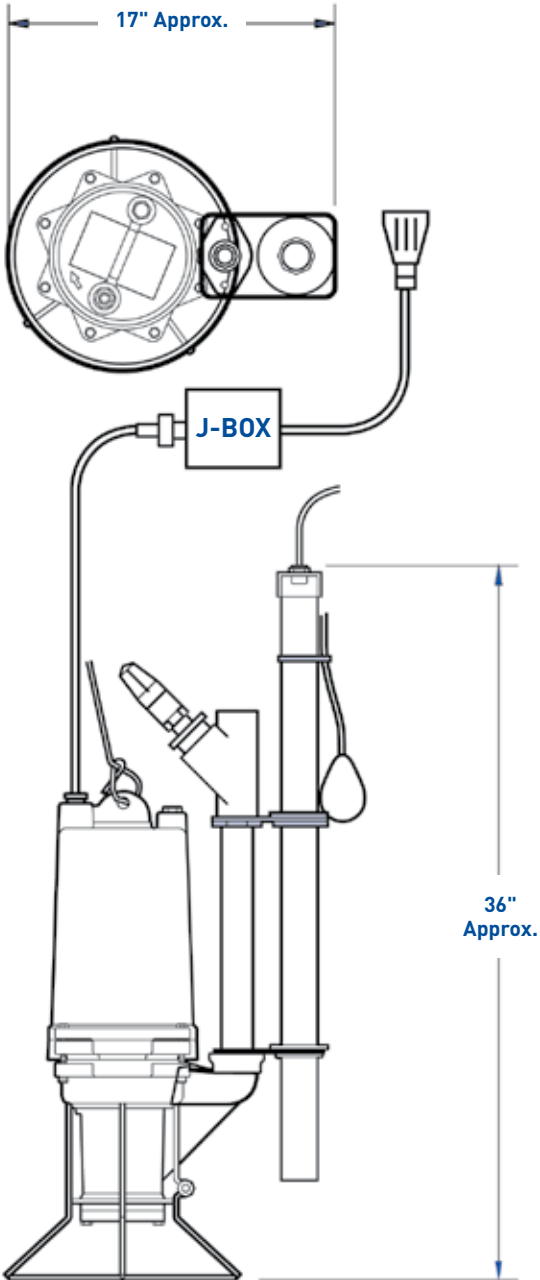
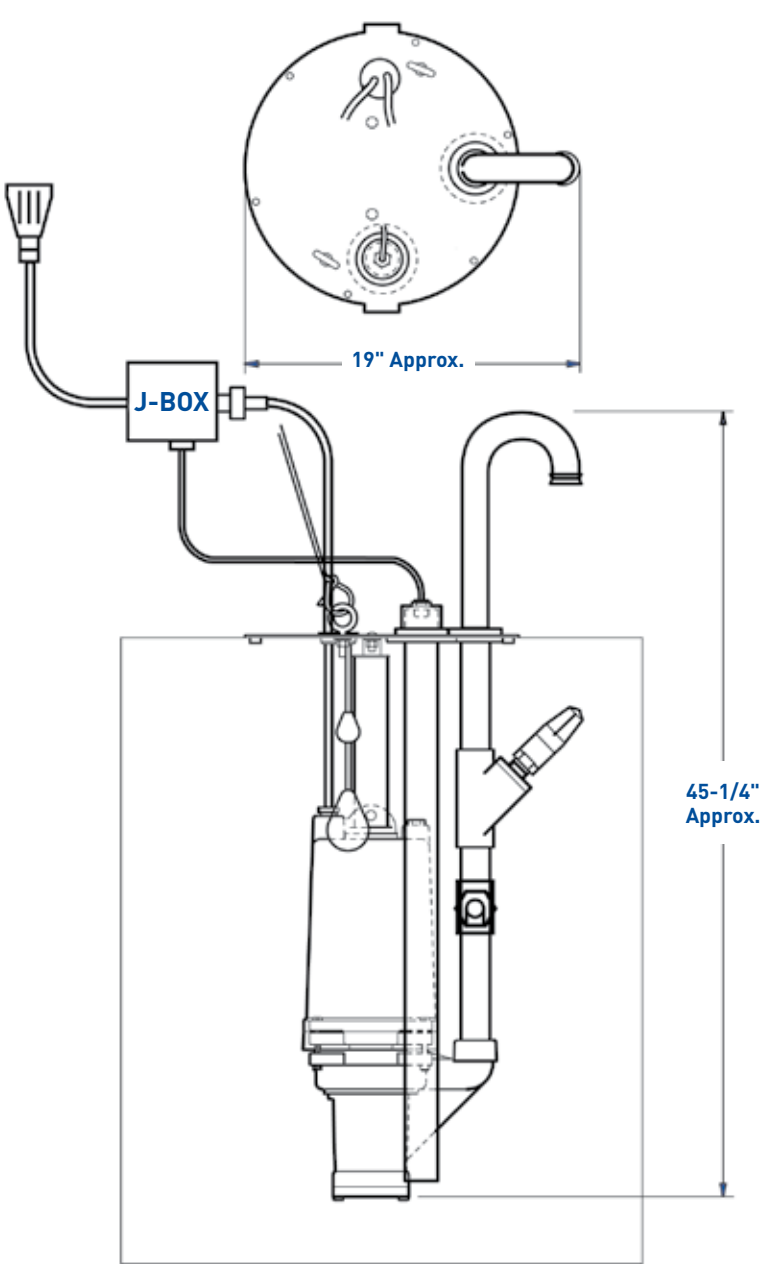

Additional Reasons for Choosing Delta Environmental®

Design Benefits

- Delta Environmental low-pressure sewage (LPS) systems install and operate over any terrain.
- Delta Environmental grinder pumps require little routine maintenance.

Reliability

- Delta Environmental submersible grinder pump systems have a 30-year record of reliability.
- Eliminates maintenance with self-cleaning scouring action
- No sewer chokes or blockages
- Quick electrical disconnect at the basin; no need to enter the residence
- When service is required, pump change-overs can be done in just 20 minutes without disruption to the homeowner

Our 30 years of experience with low-pressure sewage (LPS) pumping systems demonstrates a track record of high reliability, low retrofitting and operational costs, and remote monitoring for operations personnel.



8263 FLORIDA BLVD., DENHAM SPRINGS, LA 70727, 225-665-6162, 1 (800) 219-9183 | WWW.DELTAENVIRONMENTAL.COM

Because we are continuously improving our products and services, Pentair reserves the right to change specifications without prior notice.
K4309 08/21/13 © 2013 Pentair Ltd. All Rights Reserved.