

AURORA® FIRE PUMPS

ELECTRIC DRIVEN VERTICAL TURBINE

Section **914** Page **201**

Date **March 2017**

Supersedes Section 914 Page 201

Dated April 2006



WARNING

DO NOT OPERATE THIS MACHINE WITHOUT PROTECTIVE GUARD IN PLACE. ANY OPERATION OF THIS MACHINE WITHOUT PROTECTIVE GUARD CAN RESULT IN SEVERE BODILY INJURY.

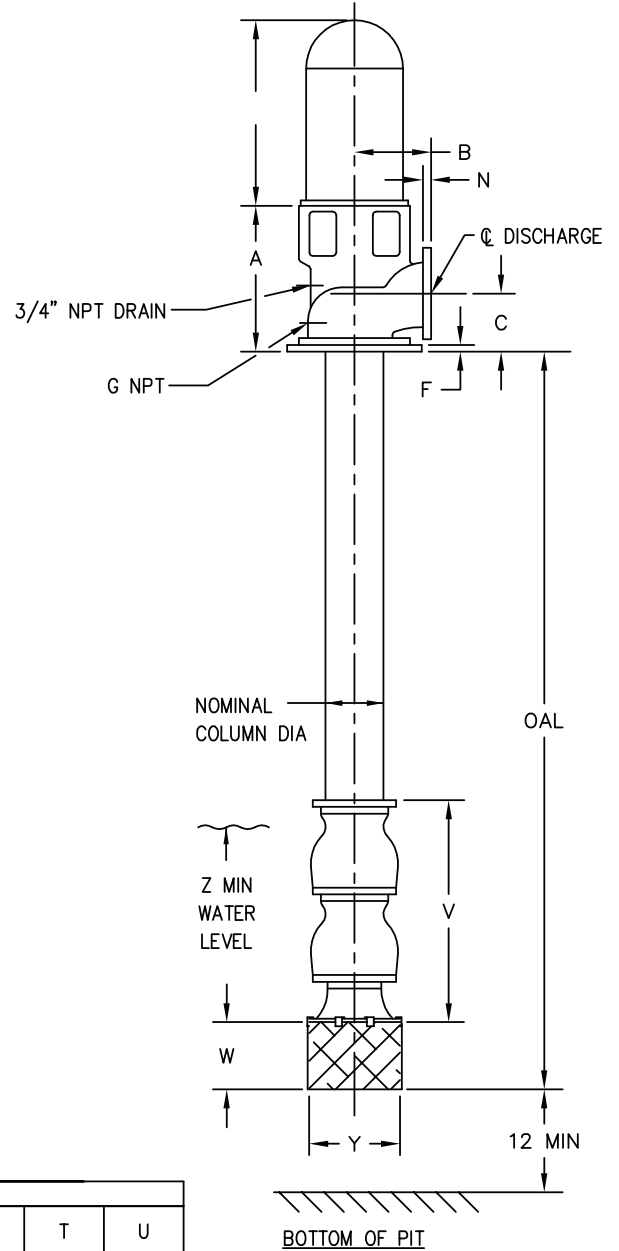
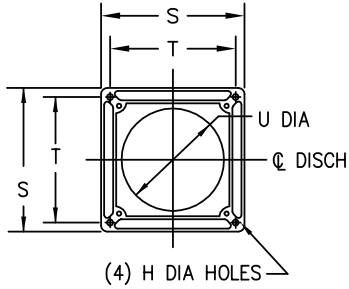

BOWL ASSEMBLY, COLUMN & SHAFTING						
BOWL SIZE & GPM	NUMBER OF STAGES	NOMINAL COLUMN DIA	V	W	Y	Z

DISCHARGE HEAD & BASEPLATE											
SIZE		A	B	C	F	G	H	N	S	T	U
"BD"	DISCH										

1. FLANGE RATINGS ARE EITHER 125# OR 250# AS DESIGNATED IN THE CERTIFICATION BLOCK BELOW FOR EACH ORDER SUBMITTAL.
2. NOT FOR CONSTRUCTION, INSTALLATION, OR APPLICATION PURPOSES UNLESS CERTIFIED. DIMENSIONS SHOWN MAY VARY DUE TO NORMAL MANUFACTURING TOLERANCES.

3. BASES ARE DESIGNED TO HAVE FULL CONTACT WITH GROUT OR A SOLE PLATE GROUTED IN PLACE.

AURORA® FIRE PUMPS

ELECTRIC DRIVEN VERTICAL TURBINE

WARNING

DO NOT OPERATE THIS MACHINE WITHOUT PROTECTIVE GUARD IN PLACE. ANY OPERATION OF THIS MACHINE WITHOUT PROTECTIVE GUARD CAN RESULT IN SEVERE BODILY INJURY.

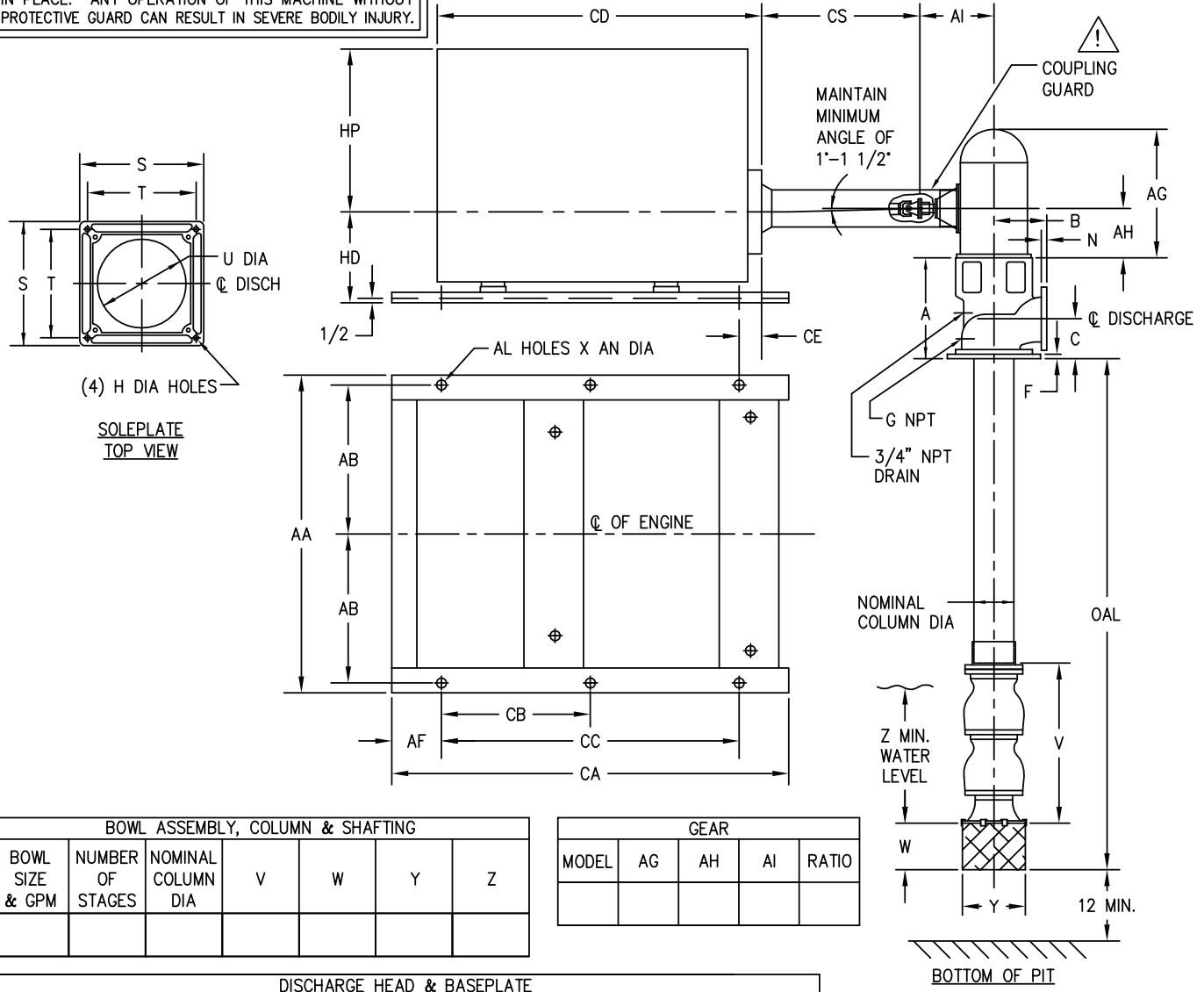

BOWL ASSEMBLY, COLUMN & SHAFTING						
BOWL SIZE & GPM	NUMBER OF STAGES	NOMINAL COLUMN DIA	V	W	Y	Z

GEAR				
MODEL	AG	AH	AI	RATIO

DISCHARGE HEAD & BASEPLATE											
SIZE		A	B	C	F	G	H	N	S	T	U
"BD"	DISCH										

ENGINE													
MODEL	AA	AB	AF	AL	AN	CA	CB	CC	CD	CE	CS	HD	HP

1. FLANGE RATINGS ARE EITHER 125# OR 250# AS DESIGNATED IN THE CERTIFICATION BLOCK BELOW FOR EACH ORDER SUBMITTAL.
2. NOT FOR CONSTRUCTION, INSTALLATION, OR APPLICATION PURPOSES UNLESS CERTIFIED. DIMENSIONS SHOWN MAY VARY DUE TO NORMAL MANUFACTURING TOLERANCES.
3. BASES ARE DESIGNED TO HAVE FULL CONTACT WITH GROUT OR A SOLE PLATE GROUTED IN PLACE.
4. CD, CE & SHAFTING LENGTH DIMENSIONED TO FACE OF DRIVE FLANGE.

AURORA® FIRE PUMPS

ELECTRIC DRIVEN VERTICAL TURBINE

BOWL ASSEMBLY, COLUMN & SHAFTING						
BOWL SIZE & GPM	MINIMUM # OF STAGES	NOMINAL COLUMN DIA	V	W	Y	Z
10FEM 250	4	6	41	6	10	21
ADD 8.25" PER ADDITIONAL STAGE						
10FEM 300	4	6	41	6	10	24
ADD 8.25" PER ADDITIONAL STAGE						
10FEM 400	4	6	41	6	10	24
ADD 8.25" PER ADDITIONAL STAGE						
11FGM 500	4	6	44 13/16	9	11 1/2	34
ADD 9.50" PER ADDITIONAL STAGE						
12FCM 750	3	8	40	7	13	34
ADD 10.75" PER ADDITIONAL STAGE						
12FCM 1000	3	8	40	7	13	34
ADD 10.75" PER ADDITIONAL STAGE						
13FGH 1250	4	8	61 13/16	11	13	34
ADD 13.06" PER ADDITIONAL STAGE						
13FGH 1500	4	8	61 13/16	11	13	34
ADD 13.06" PER ADDITIONAL STAGE						
14FGM 750	3	8	44 15/16	13	14 3/4	30
ADD 12.20" PER ADDITIONAL STAGE						
14FGM 1000	3	8	44 15/16	13	14 3/4	30
ADD 12.20" PER ADDITIONAL STAGE						
15FGH 1500	3	10	54 1/16	13	14 3/4	34
ADD 14.50" PER ADDITIONAL STAGE						

BOWL ASSEMBLY, COLUMN & SHAFTING						
BOWL SIZE & GPM	MINIMUM # OF STAGES	NOMINAL COLUMN DIA	V	W	Y	Z
15FGH 2000	3	10	54 1/16	13	14 3/4	34
ADD 14.50" PER ADDITIONAL STAGE						
15FGH 2500	3	10	54 1/16	13	14 3/4	46
ADD 14.50" PER ADDITIONAL STAGE						
17FGM 2000	3	12	49 7/8	9	18	28
ADD 13.50" PER ADDITIONAL STAGE						
17FGM 2500	3	12	49 7/8	9	18	28
ADD 13.50" PER ADDITIONAL STAGE						
17FGH 3000	3	12	49 7/8	9	18	28
ADD 16.58" PER ADDITIONAL STAGE						
17FGH 3500	3	12	49 7/8	9	18	28
ADD 16.58" PER ADDITIONAL STAGE						
17FGH 4000	3	12	49 7/8	9	18	28
ADD 16.58" PER ADDITIONAL STAGE						
19FGM 3000	2	12	47 7/8	12	23 1/2	32
ADD 17.63" PER ADDITIONAL STAGE						
19FGM 3500	2	12	47 7/8	12	23 1/2	32
ADD 17.63" PER ADDITIONAL STAGE						
19FGH 4000	2	12	47 7/8	12	23 1/2	32
ADD 17.63" PER ADDITIONAL STAGE						
19FGH 4500	2	12	47 7/8	12	23 1/2	32
ADD 17.63" PER ADDITIONAL STAGE						

DISCHARGE HEAD & BASEPLATE											
SIZE		A	B	C	F	G	H	N	S	T	U
"BD"	DISCH										
16 1/2	6 SDC	23	11 3/8	10	1 1/2	1	7/8	1 1/16	24	21	17 1/8
16 1/2	6 LAD	23	10 1/4	10	1 1/2	1	7/8	1 1/16	24	21	17 1/8
16 1/2	8 SDC	23	11 3/8	10	1 1/2	1	7/8	1 3/16	24	21	17 1/8
16 1/2	8 LAD	23	11 3/8	10	1 1/2	1	7/8	1 3/16	24	21	17 1/8
20	10 LAD	23	13 7/8	10 1/2	1 1/2	1	7/8	1 1/4	24	21	17 1/8
24 1/2	12 LS	36	19	12	1	N/A	1 1/8	1 1/4	30	27	19
24 1/2	12 SDH	28	17	13 1/2	2	3/4	1 1/8	1 7/8	32 1/2	26 3/4	24 1/2

GEAR			
MODEL	AG	AH	AI
G40	26.69	11.44	18
G60	26.69	11.44	18
G80	26.69	11.44	18
G100	26.69	11.44	18
G125	26.69	11.44	18
G150	34	13.75	20.94
G200	34	13.75	20.94
G250	34	13.75	21.75
G300	34	13.75	21.75
G350	36	13.75	21.75
G400	36	13.75	21.75
G450	37	13.75	21.75
F500	45.44	18.75	28
F590	45.44	18.75	28
F750	45.44	18.75	28

AURORA® FIRE PUMPS

ELECTRIC DRIVEN VERTICAL TURBINE

JU4H CLARKE ENGINE DIMENSIONS														
MODEL	AA	AB	AF	AL	AN	CA	CB	CC	CD	CE	CS		HD	HP
											TC	CPLG		
JU4H-UF10	32	15	5	4	1X2	40	N/A	30	35.7	2.26	13.35	20.25	40.5	
JU4H-UF12	32	15	5	4	1X2	40	N/A	30	35.7	2.26	13.35	20.25	40.5	
JU4H-UF20	32	15	5	4	1X2	40	N/A	30	35.7	2.26	13.35	20.25	40.5	
JU4H-UFH0	32	15	5	4	1X2	40	N/A	30	35.7	2.26	14.61	20.25	45	
JU4H-UFH2	32	15	5	4	1X2	40	N/A	30	35.7	2.26	14.61	20.25	45	
JU4H-UF40	32	15	5	4	1X2	40	N/A	30	35.7	2.26	14.61	20.25	45	
JU4H-UF58	32	15	5	4	1X2	40	N/A	30	35.7	2.26	19.41	20.35	45	
JU4H-UF50	32	15	5	4	1X2	40	N/A	30	35.7	2.26	19.41	20.35	45	
JU4H-UF52	32	15	5	4	1X2	40	N/A	30	35.7	2.26	19.41	20.35	45	
JU4H-UFAEA0	32	15	5	4	1X2	40	N/A	30	35.8	2.26	13.35	20.25	45.9	
JU4H-UFAGEE8	32	15	5	4	1X2	40	N/A	30	35.8	2.26	14.61	20.25	45.9	
JU4H-UFAGEF2	32	15	5	4	1X2	40	N/A	30	35.8	2.26	14.61	20.25	45.9	
JU4H-UFADJ8	32	15	5	4	1X2	40	N/A	30	35.2	2.26	14.61	20.25	45.9	
JU4H-UFADJ2	32	15	5	4	1X2	40	N/A	30	35.2	2.26	14.61	20.25	45.9	
JU4H-UFAD5G	32	15	5	4	1X2	40	N/A	30	35.32	2.26	19.41	20.35	45.23	
JU4H-UFADP0	32	15	5	4	1X2	40	N/A	30	35.32	2.26	19.41	20.35	45.23	
JU4H-UFADRO	32	15	5	4	1X2	40	N/A	30	35.32	2.26	19.41	20.35	45.23	
JU4H-UFADW8	32	15	5	4	1X2	40	N/A	30	35.32	2.26	19.41	20.35	45.23	
JU4H-UFADY8	32	15	5	4	1X2	40	N/A	30	35.32	2.26	19.41	20.35	45.23	

JU6H CLARKE ENGINE DIMENSIONS														
MODEL	AA	AB	AF	AL	AN	CA	CB	CC	CD	CE	CS		HD	HP
											TC	CPLG		
JU6H-UFDO	32	15	5	4	1X2	46	N/A	36	45.9	0.88	19.33	20.35	45.8	
JU6H-UFD2	32	15	5	4	1X2	46	N/A	36	45.9	0.88	19.33	20.35	45.8	
JU6H-UF30	32	15	5	4	1X2	46	N/A	36	45.9	0.88	19.33	20.35	45.8	
JU6H-UFABL0	32	15	5	4	1X2	46	N/A	36	45.9	0.88	19.53	20.35	45.8	
JU6H-UFABL2	32	15	5	4	1X2	46	N/A	36	45.9	0.88	19.53	20.35	45.8	
JU6H-UFM8	32	15	5	4	1X2	46	N/A	36	45.9	0.88	19.53	20.35	45.8	
JU6H-UFM0	32	15	5	4	1X2	46	N/A	36	45.9	0.88	19.53	20.35	45.8	
JU6H-UFM2	32	15	5	4	1X2	46	N/A	36	45.9	0.88	19.53	20.35	45.8	
JU6H-UF58	32	15	5	4	1X2	46	N/A	36	45.9	0.88	19.53	20.35	45.8	
JU6H-UF50	32	15	5	4	1X2	46	N/A	36	45.9	0.88	19.53	20.35	45.8	
JU6H-UF52	32	15	5	4	1X2	46	N/A	36	45.9	0.88	19.53	20.35	45.8	
JU6H-UF68	32	15	5	4	1X2	46	N/A	36	45.9	0.88	19.53	20.35	45.8	
JU6H-UF60	32	15	5	4	1X2	46	N/A	36	45.9	0.88	19.53	20.35	45.8	
JU6H-UF62	32	15	5	4	1X2	46	N/A	36	45.9	0.88	19.53	20.35	45.8	
JU6H-UFAAPG	32	15	5	4	1X2	46	N/A	36	45.9	0.88	24.02	20.45	45.8	
JU6H-UFAAQ8	32	15	5	4	1X2	46	N/A	36	45.9	0.88	24.02	20.45	45.8	
JU6H-UFAARG	32	15	5	4	1X2	46	N/A	36	45.9	0.88	24.02	20.45	45.8	
JU6H-UFAAS0	32	15	5	4	1X2	46	N/A	36	45.9	0.88	24.02	20.45	45.8	
JU6H-UFADM8	32	15	5	4	1X2	46	N/A	36	45.9	0.88	19.53	20.35	45.8	
JU6H-UFADMG	32	15	5	4	1X2	46	N/A	36	45.4	0.88	19.53	20.35	45.8	
JU6H-UFAD58	32	15	5	4	1X2	46	N/A	36	45.9	0.88	19.53	20.35	45.8	
JU6H-UFADNG	32	15	5	4	1X2	46	N/A	36	45.4	0.88	19.53	20.35	45.8	
JU6H-UFADNO	32	15	5	4	1X2	46	N/A	36	45.4	0.88	19.53	20.35	45.8	
JU6H-UFADP0	32	15	5	4	1X2	46	N/A	36	45.4	0.88	24.02	20.45	45.8	
JU6H-UFADP8	32	15	5	4	1X2	46	N/A	36	45.4	0.88	24.02	20.45	45.8	
JU6H-UFADQ0	32	15	5	4	1X2	46	N/A	36	45.4	0.88	19.53	20.35	45.8	
JU6H-UFAD88	32	15	5	4	1X2	46	N/A	36	45.4	0.88	24.02	20.45	45.8	
JU6H-UFADR8	32	15	5	4	1X2	46	N/A	36	45.4	0.88	24.02	20.45	45.8	
JU6H-UFADRO	32	15	5	4	1X2	46	N/A	36	45.4	0.88	19.53	20.35	45.8	
JU6H-UFADS8	32	15	5	4	1X2	46	N/A	36	45.4	0.88	24.02	20.45	45.8	
JU6H-UFADS0	32	15	5	4	1X2	46	N/A	36	45.4	0.88	24.02	20.45	45.8	
JU6H-UFADT0	32	15	5	4	1X2	46	N/A	36	45.4	0.88	24.02	20.45	45.8	
JU6H-UFADW8	32	15	5	4	1X2	46	N/A	36	45.4	0.88	24.49	20.45	45.8	
JU6H-UFADX8	32	15	5	4	1X2	46	N/A	36	45.4	0.88	24.49	20.45	45.8	
JU6H-UFAD98	32	15	5	4	1X2	46	N/A	36	45.4	0.88	24.49	20.45	45.8	

AURORA® FIRE PUMPS

ELECTRIC DRIVEN VERTICAL TURBINE

Section **914** Page **205**

Date **March 2017**

Supersedes Section 914 Page 205

Dated September 2011

JW6H CLARKE ENGINE DIMENSIONS														
MODEL	AA	AB	AF	AL	AN	CA	CB	CC	CD	CE	CS		HD	HP
											TC	CPLG		
JW6H-UFAAM8	36	17	5	4	1X2	46	N/A	36	51.7	2.90	26.50	24.45	51.1	
JW6H-UFAA80	36	17	5	4	1X2	46	N/A	36	51.7	2.90	26.50	24.45	51.1	
JW6H-UFADF0	36	17	5	4	1X2	46	N/A	36	51.7	2.90	24.49	24.45	51.1	
JW6H-UFADJ0	36	17	5	4	1X2	46	N/A	36	51.7	2.90	26.50	24.45	51.1	
JW6H-UFAD70	36	17	5	4	1X2	46	N/A	36	51.7	2.90	26.50	24.45	51.1	
JW6H-UFAD80	36	17	5	4	1X2	46	N/A	36	57.7	2.90	26.50	24.45	51.1	

JX6H CLARKE ENGINE DIMENSIONS														
MODEL	AA	AB	AF	AL	AN	CA	CB	CC	CD	CE	CS		HD	HP
											TC	CPLG		
JX6H-UFADF0	40	19	5	4	1X2	54	N/A	44	54	1.4	25.73	26.45	48.9	
JX6H-UFAD60	40	19	5	4	1X2	54	N/A	44	54	1.4	25.73	26.45	48.9	
JX6H-UFADNO	40	19	5	4	1X2	54	N/A	44	54	1.4	25.73	26.45	48.9	
JX6H-UFADP0	40	19	5	4	1X2	54	N/A	44	54	1.4	25.73	26.45	48.9	
JX6H-UFAD88	40	19	5	4	1X2	54	N/A	44	54	1.4	25.73	26.45	48.9	

DP6H CLARKE ENGINE DIMENSIONS														
MODEL	AA	AB	AF	AL	AN	CA	CB	CC	CD	CE	CS		HD	HP
											TC	CPLG		
DP6H-UFAA88	36	17	4.87	4	1X2	46	N/A	36.38	53	2.90	24.49	24.45	46.98	
DP6H-UFAA50	36	17	4.87	4	1X2	46	N/A	36.38	53	2.90	24.49	24.45	46.98	
DP6H-UFAA62	36	17	4.87	4	1X2	46	N/A	36.38	53	2.90	24.49	24.45	46.98	
DP6H-UFAA70	36	17	4.87	4	1X2	46	N/A	36.38	53	2.90	24.49	24.45	46.98	

DQ6H CLARKE ENGINE DIMENSIONS														
MODEL	AA	AB	AF	AL	AN	CA	CB	CC	CD	CE	CS		HD	HP
											TC	CPLG		
DQ6H-UFAA48	36	17	5	4	1X2	46	N/A	36	51.9	2.90	25.04	24.45	49	
DQ6H-UFAA40	36	17	5	4	1X2	46	N/A	36	51.9	2.90	25.04	24.45	49	
DQ6H-UFAA50	36	17	5	4	1X2	46	N/A	36	51.9	2.90	25.04	24.45	49	
DQ6H-UFAA60	36	17	5	4	1X2	46	N/A	36	51.9	2.90	25.04	24.45	49	
DQ6H-UFAA88	36	17	5	4	1X2	46	N/A	36	51.9	2.90	25.04	24.45	49	
DQ6H-UFAA98	36	17	5	4	1X2	46	N/A	36	51.9	2.90	25.04	24.45	49	

DR8H CLARKE ENGINE DIMENSIONS														
MODEL	AA	AB	AF	AL	AN	CA	CB	CC	CD	CE	CS		HD	HP
											TC	CPLG		
DR8H-UFAA40	36	17	5	4	1X2	46	N/A	36	51.9	2.90	25.04	24.45	49	
DR8H-UFAA5G	36	17	5	4	1X2	46	N/A	36	51.9	2.90	25.04	24.45	49	
DR8H-UFAA68	36	17	5	4	1X2	46	N/A	36	51.9	2.90	25.04	24.45	49	
DR8H-UFAA62	36	17	5	4	1X2	46	N/A	36	51.9	2.90	25.04	24.45	49	

DS0H CLARKE ENGINE DIMENSIONS														
MODEL	AA	AB	AF	AL	AN	CA	CB	CC	CD	CE	CS		HD	HP
											TC	CPLG		
DS0H-UFAAN0	40	19	5	4	1X2	47	N/A	37	55.31	2.90	25.04	32.45	46.47	
DS0H-UFAA68	40	19	5	4	1X2	47	N/A	37	55.31	2.90	25.04	32.45	46.47	
DS0H-UFAA60	40	19	5	4	1X2	47	N/A	37	55.31	2.90	25.04	32.45	46.47	

DT2H CLARKE ENGINE DIMENSIONS														
MODEL	AA	AB	AF	AL	AN	CA	CB	CC	CD	CE	CS		HD	HP
											TC	CPLG		
DT2H-UFAA20	54	26	5	4	1X2	70	N/A	35	62.83	0.43	25.06	34.45	46.6	
DT2H-UFAA58	54	26	5	4	1X2	70	N/A	35	62.83	0.43	25.06	34.45	46.6	
DT2H-UFAA50	54	26	5	4	1X2	70	N/A	35	62.83	0.43	25.06	34.45	46.6	
DT2H-UFAA60	54	26	5	4	1X2	70	N/A	35	58.82	0.35	32.31	34.45	45.3	
DT2H-UFAA98	54	26	5	4	1X2	70	N/A	35	58.82	0.35	32.31	34.65	45.3	
DT2H-UFAA92	54	26	5	4	1X2	70	N/A	35	58.82	0.35	32.31	34.65	45.3	

AURORA® FIRE PUMPS

ELECTRIC DRIVEN VERTICAL TURBINE

CFP5E CUMMINS ENGINE DIMENSIONS														
MODEL	AA	AB	AF	AL	AN	CB	CA	CC	CD	CE	CS		HD	HP
											TC	CPLG		
CFP5E-F10	28.5	13.38	6	4	1	N/A	42.5	30.5	37.9	4.5	14.87	22.5	42.64	
CFP5E-F20	28.5	13.38	6	4	1	N/A	42.5	30.5	37.9	4.5	14.87	22.5	42.64	
CFP5E-F30	28.5	13.38	6	4	1	N/A	42.5	30.5	37.9	4.5	14.87	22.5	42.64	
CFP5E-F40	28.5	13.38	6	4	1	N/A	42.5	30.5	37.9	4.5	14.87	22.5	42.64	
CFP5E-F50	28.5	13.38	6	4	1	N/A	42.5	30.5	37.9	4.5	14.87	22.5	42.64	

CFP59 CUMMINS ENGINE DIMENSIONS														
MODEL	AA	AB	AF	AL	AN	CA	CB	CC	CD	CE	CS		HD	HP
											TC	CPLG		
CFP59-F10	30.75	14.5	6	4	1	60	N/A	48	39.66	4.5	14.87	22.5	43.54	
CFP59-F15	30.75	14.5	6	4	1	60	N/A	48	39.66	4.5	14.87	22.5	43.54	
CFP59-F20	30.75	14.5	6	4	1	60	N/A	48	39.66	4.5	14.87	22.5	43.54	
CFP59-F25	30.75	14.5	6	4	1	60	N/A	48	39.66	4.5	14.87	22.5	43.54	
CFP59-F40	30.75	14.5	6	4	1	60	N/A	48	39.66	4.5	14.87	22.5	43.54	
CFP59-F50	30.75	14.5	6	4	1	60	N/A	48	39.66	4.5	14.87	22.5	43.54	

CFP7E CUMMINS ENGINE DIMENSIONS														
MODEL	AA	AB	AF	AL	AN	CA	CB	CC	CD	CE	CS		HD	HP
											TC	CPLG		
CFP7E-F10	30.75	14.5	6	4	1	60	N/A	48	48.93	2.88	14.97	22.5	43.36	
CFP7E-F20	30.75	14.5	6	4	1	60	N/A	48	48.93	2.88	14.97	22.5	43.36	
CFP7E-F30	30.75	14.5	6	4	1	60	N/A	48	48.93	2.88	14.97	22.5	43.36	
CFP7E-F40	30.75	14.5	6	4	1	60	N/A	48	47.41	4.4	16.52	22.5	43.36	
CFP7E-F50	30.75	14.5	6	4	1	60	N/A	48	47.41	4.4	16.52	22.5	43.36	
CFP7E-F60	30.75	14.5	6	4	1	60	N/A	48	47.41	4.4	16.52	22.5	43.36	

CFP83 CUMMINS ENGINE DIMENSIONS														
MODEL	AA	AB	AF	AL	AN	CA	CB	CC	CD	CE	CS		HD	HP
											TC	CPLG		
CFP83-F10	30.75	14.5	6	4	1	60	N/A	48	48.56	4.38	16.52	22.5	46.25	
CFP83-F20	30.75	14.5	6	4	1	60	N/A	48	48.56	4.38	16.52	22.5	46.25	
CFP83-F30	30.75	14.5	6	4	1	60	N/A	48	48.56	4.38	16.52	22.5	46.25	

CFP9E CUMMINS ENGINE DIMENSIONS															
RPM ONLY	MODEL	AA	AB	AF	AL	AN	CA	CB	CC	CD	CE	CS		HD	HP
												TC	CPLG		
ALL OTHERS	CFP9E-F10	30.75	14.5	6	4	1	60	N/A	48	50.63	0.15	19.85	22.5	46.26	
	CFP9E-F20	30.75	14.5	6	4	1	60	N/A	48	50.63	0.15	19.85	22.5	46.26	
	CFP9E-F30	30.75	14.5	6	4	1	60	N/A	48	50.63	0.15	19.85	22.5	46.26	
	CFP9E-F40	30.75	14.5	6	4	1	60	N/A	48	50.63	0.15	19.85	22.5	46.26	
	CFP9E-F50	30.75	14.5	6	4	1	60	N/A	48	50.63	0.15	19.85	22.5	46.26	
	CFP9E-F60	30.75	14.5	6	4	1	60	N/A	48	50.63	0.15	19.85	22.5	46.26	
1470/1760/1900	CFP9E-F20	30.75	14.5	6	4	1	60	N/A	48	50.67	0.19	19.81	22.5	46.26	
1470/1760/1900	CFP9E-F30	30.75	14.5	6	4	1	60	N/A	48	50.67	0.19	19.81	22.5	46.26	
1470/1760/1900	CFP9E-F40	30.75	14.5	6	4	1	60	N/A	48	50.67	0.19	19.81	22.5	46.26	
1470/1760	CFP9E-F50	30.75	14.5	6	4	1	60	N/A	48	50.67	0.19	19.81	22.5	46.26	
1470/1760	CFP9E-F60	30.75	14.5	6	4	1	60	N/A	48	50.67	0.19	19.81	22.5	46.26	
1900/2100	CFP9E-F50	30.75	14.5	6	4	1	60	N/A	48	50.67	0.19	19.81	22.5	46.26	
1900/2100	CFP9E-F60	30.75	14.5	6	4	1	60	N/A	48	50.67	0.19	19.81	22.5	46.26	

CFP11E CUMMINS ENGINE DIMENSIONS															
RPM ONLY	MODEL	AA	AB	AF	AL	AN	CA	CB	CC	CD	CE	CS		HD	HP
												TC	CPLG		
ALL OTHERS	CFP11E-F10	30.75	14.5	6	4	1	66	N/A	54	54.32	3.57	24.61	22.38	38.45	
	CFP11E-F20	30.75	14.5	6	4	1	66	N/A	54	54.32	3.57	24.61	22.38	38.45	
2100	CFP11E-F10	30.75	14.5	6	4	1	66	N/A	54	59.22	1.33	19.71	22.38	38.45	
2100	CFP11E-F20	30.75	14.5	6	4	1	66	N/A	54	59.22	1.33	19.71	22.38	38.45	

AURORA® FIRE PUMPS

ELECTRIC DRIVEN VERTICAL TURBINE

CFP15E CUMMINS ENGINE DIMENSIONS														
MODEL	AA	AB	AF	AL	AN	CA	CB	CC	CD	CE	CS		HD	HP
											TC	CPLG		
CFP15E-F10	35.95	16.78	24	4	0.88	84	N/A	42	65.97	4.44	24.61	35.51	41.43	
CFP15E-F20	35.95	16.78	24	4	0.88	84	N/A	42	65.97	4.44	24.61	35.51	41.43	
CFP15E-F30	35.95	16.78	24	4	0.88	84	N/A	42	65.97	4.44	24.61	35.51	41.43	
CFP15E-F40	35.95	16.78	24	4	0.88	84	N/A	42	66.42	3.99	24.16	35.51	41.43	
CFP15E-F50	35.95	16.78	24	4	0.88	84	N/A	42	66.42	3.99	24.16	35.51	41.43	
CFP15E-F60	35.95	16.78	24	4	0.88	84	N/A	42	66.42	3.99	24.16	35.51	41.43	
CFP15E-F70	35.95	16.78	24	4	0.88	84	N/A	42	66.42	3.99	24.16	35.51	41.43	

CFP23E CUMMINS ENGINE DIMENSIONS														
MODEL	AA	AB	AF	AL	AN	CA	CB	CC	CD	CE	CS		HD	HP
											TC	CPLG		
CFP23E-F10	53.48	25.5	6	6	0.88	108	48	96	80.02	2.25	25	34.5	63.5	
CFP23E-F15	53.48	25.5	6	6	0.88	108	48	96	80.02	2.25	25	34.5	63.5	
CFP23E-F20	53.48	25.5	6	6	0.88	108	48	96	80.02	2.25	25	34.5	63.5	
CFP23E-F25	53.48	25.5	6	6	0.88	108	48	96	80.02	2.25	25	34.5	63.5	
CFP23E-F30	53.48	25.5	6	6	0.88	108	48	96	80.02	2.25	25	34.5	63.5	
CFP23E-F35	53.48	25.5	6	6	0.88	108	48	96	80.02	2.25	25	34.5	63.5	
CFP23E-F40	53.48	25.5	6	6	0.88	108	48	96	80.02	2.25	25	34.5	63.5	
CFP23E-F50	53.48	25.5	6	6	0.88	108	48	96	80.02	2.25	25	34.5	63.5	
CFP23E-F60	53.48	25.5	6	6	0.88	108	48	96	80.02	2.25	25	34.5	63.5	
CFP23E-F70	53.48	25.5	6	6	0.88	108	48	96	80.02	2.25	25	34.5	63.5	

CFP30E CUMMINS ENGINE DIMENSIONS														
MODEL	AA	AB	AF	AL	AN	CA	CB	CC	CD	CE	CS		HD	HP
											TC	CPLG		
CFP30E-F10	37.88	17.5	1.63	6	0.88	95.38	67.5	92.13	RTF	RTF	RTF	26	57.86	
CFP30E-F20	37.88	17.5	1.63	6	0.88	95.38	67.5	92.13	RTF	RTF	RTF	26	57.86	
CFP30E-F30	37.88	17.5	1.63	6	0.88	95.38	67.5	92.13	RTF	RTF	RTF	26	57.86	
CFP30E-F40	37.88	17.5	1.63	6	0.88	95.38	67.5	92.13	RTF	RTF	RTF	26	57.86	

CFP50 CUMMINS ENGINE DIMENSIONS														
MODEL	AA	AB	AF	AL	AN	CA	CB	CC	CD	CE	CS		HD	HP
											TC	CPLG		
CFP50-F1	82.26	39.75	10	4	1	130	N/A	36.67	120.8	40.24	36.55	32	58.88	
CFP50-F2	82.26	39.75	10	4	1	130	N/A	36.67	120.8	40.24	36.55	32	58.88	
CFP50-F3	82.26	39.75	10	4	1	130	N/A	36.67	120.8	40.24	36.55	32	58.88	
CFP50-F4	82.26	39.75	10	4	1	130	N/A	36.67	120.8	40.24	36.55	32	58.88	
CFP50-F10	82.26	39.75	10	4	1	130	N/A	36.67	120.8	40.24	36.55	32	58.88	
CFP50-F20	82.26	39.75	10	4	1	130	N/A	36.67	120.8	40.24	36.55	32	58.88	
CFP50-F30	82.26	39.75	10	4	1	130	N/A	36.67	120.8	40.24	36.55	32	58.88	
CFP50-F40	82.26	39.75	10	4	1	130	N/A	36.67	120.8	40.24	36.55	32	58.88	

AURORA® FIRE PUMPS

DIESEL DRIVEN VERTICAL TURBINE



WARNING

DO NOT OPERATE THIS MACHINE WITHOUT PROTECTIVE GUARD IN PLACE. ANY OPERATION OF THIS MACHINE WITHOUT PROTECTIVE GUARD CAN RESULT IN SEVERE BODILY INJURY.

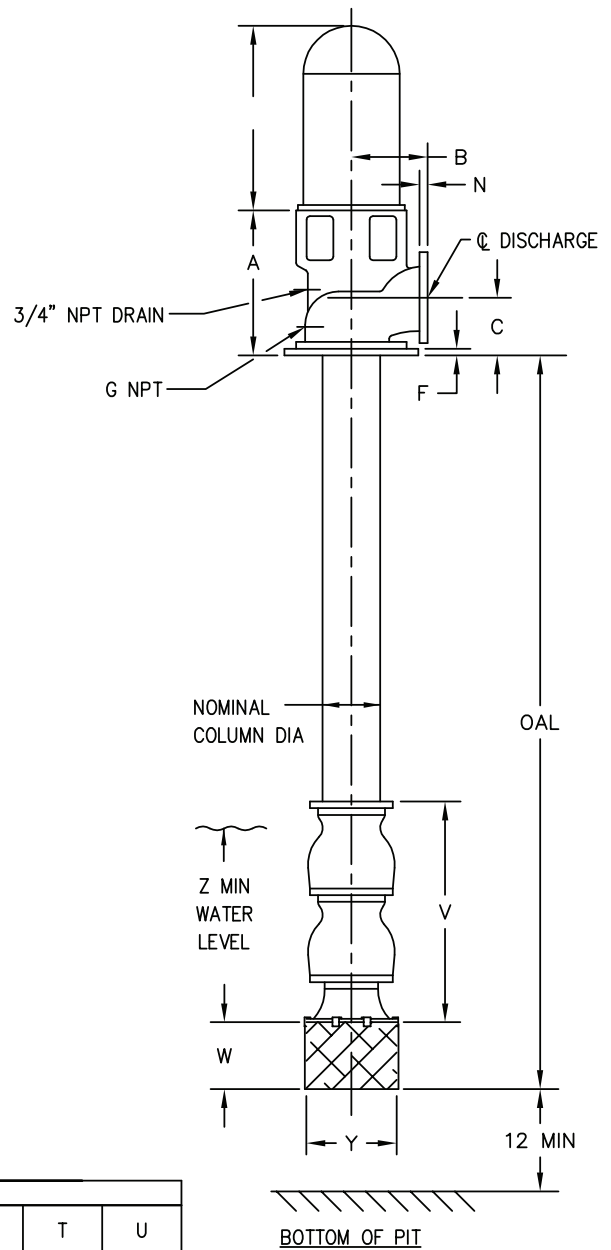
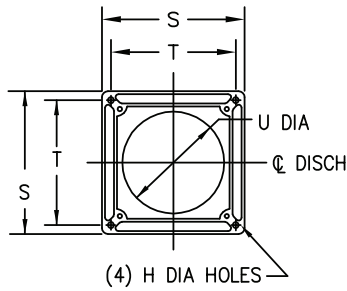

BOWL ASSEMBLY, COLUMN & SHAFTING						
BOWL SIZE & GPM	NUMBER OF STAGES	NOMINAL COLUMN DIA	V	W	Y	Z

DISCHARGE HEAD & BASEPLATE											
SIZE		A	B	C	F	G	H	N	S	T	U
"BD"	DISCH										

1. FLANGE RATINGS ARE EITHER 125# OR 250# AS DESIGNATED IN THE CERTIFICATION BLOCK BELOW FOR EACH ORDER SUBMITTAL.
2. NOT FOR CONSTRUCTION, INSTALLATION, OR APPLICATION PURPOSES UNLESS CERTIFIED. DIMENSIONS SHOWN MAY VARY DUE TO NORMAL MANUFACTURING TOLERANCES.

3. BASES ARE DESIGNED TO HAVE FULL CONTACT WITH GROUT OR A SOLE PLATE GROUTED IN PLACE.

AURORA® FIRE PUMPS

DIESEL DRIVEN VERTICAL TURBINE

WARNING
 DO NOT OPERATE THIS MACHINE WITHOUT PROTECTIVE GUARD IN PLACE. ANY OPERATION OF THIS MACHINE WITHOUT PROTECTIVE GUARD CAN RESULT IN SEVERE BODILY INJURY.

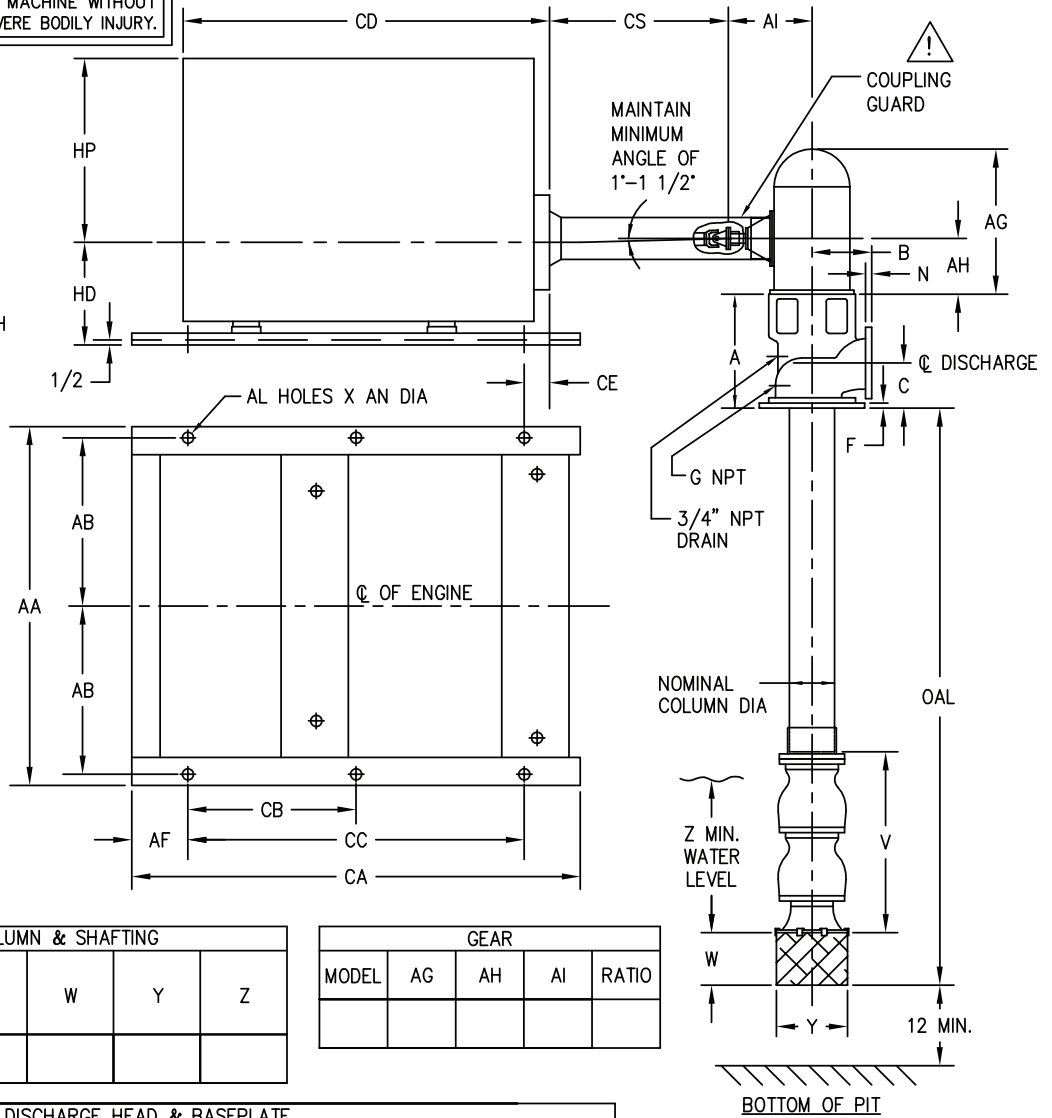
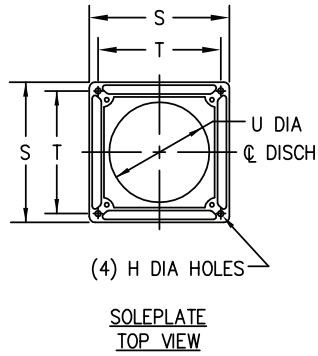

BOWL ASSEMBLY, COLUMN & SHAFTING						
BOWL SIZE & GPM	NUMBER OF STAGES	NOMINAL COLUMN DIA	V	W	Y	Z

GEAR				
MODEL	AG	AH	AI	RATIO

DISCHARGE HEAD & BASEPLATE											
SIZE		A	B	C	F	G	H	N	S	T	U
"BD"	DISCH										

ENGINE													
MODEL	AA	AB	AF	AL	AN	CA	CB	CC	CD	CE	CS	HD	HP

- FLANGE RATINGS ARE EITHER 125# OR 250# AS DESIGNATED IN THE CERTIFICATION BLOCK BELOW FOR EACH ORDER SUBMITTAL.
- NOT FOR CONSTRUCTION, INSTALLATION, OR APPLICATION PURPOSES UNLESS CERTIFIED. DIMENSIONS SHOWN MAY VARY DUE TO NORMAL MANUFACTURING TOLERANCES.
- BASES ARE DESIGNED TO HAVE FULL CONTACT WITH GROUT OR A SOLE PLATE GROUTED IN PLACE.
- CD, CE & SHAFTING LENGTH DIMENSIONED TO FACE OF DRIVE FLANGE.

AURORA® FIRE PUMPS

DIESEL DRIVEN VERTICAL TURBINE

BOWL ASSEMBLY, COLUMN & SHAFTING						
BOWL SIZE & GPM	MINIMUM # OF STAGES	NOMINAL COLUMN DIA	V	W	Y	Z
10M 250	4	6	41	6	10	21
ADD 8.25" PER ADDITIONAL STAGE						
10M 300	4	6	41	6	10	24
ADD 8.25" PER ADDITIONAL STAGE						
10M 400	4	6	41	6	10	24
ADD 8.25" PER ADDITIONAL STAGE						
11M 500	4	6	44 ¹³ / ₁₆	9	11 ¹ / ₂	34
ADD 9.50" PER ADDITIONAL STAGE						
12M 750	3	8	40	7	13	34
ADD 10.75" PER ADDITIONAL STAGE						
12M 1000	3	8	40	7	13	34
ADD 10.75" PER ADDITIONAL STAGE						
13H 1250	4	8	61 ¹³ / ₁₆	11	13	34
ADD 13.06" PER ADDITIONAL STAGE						
13H 1500	4	8	61 ¹³ / ₁₆	11	13	34
ADD 13.06" PER ADDITIONAL STAGE						
14M 750	3	8	44 ¹⁵ / ₁₆	13	14 ³ / ₄	30
ADD 12.20" PER ADDITIONAL STAGE						
14M 1000	3	8	44 ¹⁵ / ₁₆	13	14 ³ / ₄	30
ADD 12.20" PER ADDITIONAL STAGE						
15H 1500	3	10	54 ¹ / ₁₆	13	14 ³ / ₄	34
ADD 14.50" PER ADDITIONAL STAGE						

BOWL ASSEMBLY, COLUMN & SHAFTING						
BOWL SIZE & GPM	MINIMUM # OF STAGES	NOMINAL COLUMN DIA	V	W	Y	Z
15H 2000	3	10	54 ¹ / ₁₆	13	14 ³ / ₄	34
ADD 14.50" PER ADDITIONAL STAGE						
15H 2500	3	10	54 ¹ / ₁₆	13	14 ³ / ₄	46
ADD 14.50" PER ADDITIONAL STAGE						
17M 2000	3	12	49 ⁷ / ₈	9	18	28
ADD 13.50" PER ADDITIONAL STAGE						
17M 2500	3	12	49 ⁷ / ₈	9	18	28
ADD 13.50" PER ADDITIONAL STAGE						
17H 3000	3	12	49 ⁷ / ₈	9	18	28
ADD 16.58" PER ADDITIONAL STAGE						
17H 3500	3	12	49 ⁷ / ₈	9	18	28
ADD 16.58" PER ADDITIONAL STAGE						
17H 4000	3	12	49 ⁷ / ₈	9	18	28
ADD 16.58" PER ADDITIONAL STAGE						
19A 3000	2	12	47 ⁷ / ₈	12	23 ¹ / ₂	32
ADD 17.63" PER ADDITIONAL STAGE						
19A 3500	2	12	47 ⁷ / ₈	12	23 ¹ / ₂	32
ADD 17.63" PER ADDITIONAL STAGE						
19B 4000	2	12	47 ⁷ / ₈	12	23 ¹ / ₂	32
ADD 17.63" PER ADDITIONAL STAGE						
19B 4500	2	12	47 ⁷ / ₈	12	23 ¹ / ₂	32
ADD 17.63" PER ADDITIONAL STAGE						

DISCHARGE HEAD & BASEPLATE											
SIZE		A	B	C	F	G	H	N	S	T	U
"BD"	DISCH										
16 ¹ / ₂	6 CT	23	11 ³ / ₈	10	1 ¹ / ₂	1	7 ⁷ / ₈	1 ¹ / ₁₆	24	21	17 ¹ / ₈
16 ¹ / ₂	6 D	23	10 ¹ / ₄	10	1 ¹ / ₂	1	7 ⁷ / ₈	1 ¹ / ₁₆	24	21	17 ¹ / ₈
16 ¹ / ₂	8 CT	23	11 ³ / ₈	10	1 ¹ / ₂	1	7 ⁷ / ₈	1 ³ / ₁₆	24	21	17 ¹ / ₈
16 ¹ / ₂	8 D	23	11 ³ / ₈	10	1 ¹ / ₂	1	7 ⁷ / ₈	1 ³ / ₁₆	24	21	17 ¹ / ₈
20	10 D	23	13 ⁷ / ₈	10 ¹ / ₂	1 ¹ / ₂	1	7 ⁷ / ₈	1 ¹ / ₄	24	21	17 ¹ / ₈
24 ¹ / ₂	12 LS	36	19	12	1	N/A	1 ¹ / ₈	1 ¹ / ₄	30	27	19
24 ¹ / ₂	12 SDH	28	17	13 ¹ / ₂	2	3 ³ / ₄	1 ¹ / ₈	1 ⁷ / ₈	32 ¹ / ₂	26 ⁵ / ₃₂	24 ¹ / ₂

GEAR			
MODEL	AG	AH	AI
G40	26.69	11.44	18
G60	26.69	11.44	18
G80	26.69	11.44	18
G100	26.69	11.44	18
G125	26.69	11.44	18
G150	34	13.75	20.94
G200	34	13.75	20.94
G250	34	13.75	21.75
G300	34	13.75	21.75
G350	36	13.75	21.75
G400	36	13.75	21.75
G450	37	13.75	21.75
F500	45.44	18.75	28
F590	45.44	18.75	28
F750	45.44	18.75	28

AURORA® FIRE PUMPS

DIESEL DRIVEN VERTICAL TURBINE

Section **914** Page **211**

Date **March 2017**

Supersedes Section 914 Page 211

Dated September 2011

JU4H CLARKE ENGINE DIMENSIONS														
MODEL	AA	AB	AF	AL	AN	CA	CB	CC	CD	CE	CS		HD	HP
											TC	CPLG		
JU4H-UF10	32	15	5	4	1X2	40	N/A	30	35.7	2.26	13.35	20.25	40.5	
JU4H-UF12	32	15	5	4	1X2	40	N/A	30	35.7	2.26	13.35	20.25	40.5	
JU4H-UF20	32	15	5	4	1X2	40	N/A	30	35.7	2.26	13.35	20.25	40.5	
JU4H-UFH0	32	15	5	4	1X2	40	N/A	30	35.7	2.26	14.61	20.25	45	
JU4H-UFH2	32	15	5	4	1X2	40	N/A	30	35.7	2.26	14.61	20.25	45	
JU4H-UF40	32	15	5	4	1X2	40	N/A	30	35.7	2.26	14.61	20.25	45	
JU4H-UF58	32	15	5	4	1X2	40	N/A	30	35.7	2.26	19.41	20.35	45	
JU4H-UF50	32	15	5	4	1X2	40	N/A	30	35.7	2.26	19.41	20.35	45	
JU4H-UF52	32	15	5	4	1X2	40	N/A	30	35.7	2.26	19.41	20.35	45	
JU4H-UFAEA0	32	15	5	4	1X2	40	N/A	30	35.8	2.26	13.35	20.25	45.9	
JU4H-UFACE8	32	15	5	4	1X2	40	N/A	30	35.8	2.26	14.61	20.25	45.9	
JU4H-UFAEF2	32	15	5	4	1X2	40	N/A	30	35.8	2.26	14.61	20.25	45.9	
JU4H-UFADJ8	32	15	5	4	1X2	40	N/A	30	35.2	2.26	14.61	20.25	45.9	
JU4H-UFADJ2	32	15	5	4	1X2	40	N/A	30	35.2	2.26	14.61	20.25	45.9	
JU4H-UFAD5G	32	15	5	4	1X2	40	N/A	30	35.32	2.26	19.41	20.35	45.23	
JU4H-UFADP0	32	15	5	4	1X2	40	N/A	30	35.32	2.26	19.41	20.35	45.23	
JU4H-UFADRO	32	15	5	4	1X2	40	N/A	30	35.32	2.26	19.41	20.35	45.23	
JU4H-UFADW8	32	15	5	4	1X2	40	N/A	30	35.32	2.26	19.41	20.35	45.23	
JU4H-UFADY8	32	15	5	4	1X2	40	N/A	30	35.32	2.26	19.41	20.35	45.23	

JU6H CLARKE ENGINE DIMENSIONS														
MODEL	AA	AB	AF	AL	AN	CA	CB	CC	CD	CE	CS		HD	HP
											TC	CPLG		
JU6H-UFDO	32	15	5	4	1X2	46	N/A	36	45.9	0.88	19.33	20.35	45.8	
JU6H-UFD2	32	15	5	4	1X2	46	N/A	36	45.9	0.88	19.33	20.35	45.8	
JU6H-UF30	32	15	5	4	1X2	46	N/A	36	45.9	0.88	19.33	20.35	45.8	
JU6H-UFABLO	32	15	5	4	1X2	46	N/A	36	45.9	0.88	19.53	20.35	45.8	
JU6H-UFABL2	32	15	5	4	1X2	46	N/A	36	45.9	0.88	19.53	20.35	45.8	
JU6H-UFM8	32	15	5	4	1X2	46	N/A	36	45.9	0.88	19.53	20.35	45.8	
JU6H-UFM0	32	15	5	4	1X2	46	N/A	36	45.9	0.88	19.53	20.35	45.8	
JU6H-UFM2	32	15	5	4	1X2	46	N/A	36	45.9	0.88	19.53	20.35	45.8	
JU6H-UF58	32	15	5	4	1X2	46	N/A	36	45.9	0.88	19.53	20.35	45.8	
JU6H-UF50	32	15	5	4	1X2	46	N/A	36	45.9	0.88	19.53	20.35	45.8	
JU6H-UF52	32	15	5	4	1X2	46	N/A	36	45.9	0.88	19.53	20.35	45.8	
JU6H-UF68	32	15	5	4	1X2	46	N/A	36	45.9	0.88	19.53	20.35	45.8	
JU6H-UF60	32	15	5	4	1X2	46	N/A	36	45.9	0.88	19.53	20.35	45.8	
JU6H-UF62	32	15	5	4	1X2	46	N/A	36	45.9	0.88	19.53	20.35	45.8	
JU6H-UFAAPG	32	15	5	4	1X2	46	N/A	36	45.9	0.88	24.02	20.45	45.8	
JU6H-UFAAQ8	32	15	5	4	1X2	46	N/A	36	45.9	0.88	24.02	20.45	45.8	
JU6H-UFAAARG	32	15	5	4	1X2	46	N/A	36	45.9	0.88	24.02	20.45	45.8	
JU6H-UFAAAS0	32	15	5	4	1X2	46	N/A	36	45.9	0.88	24.02	20.45	45.8	
JU6H-UFADM8	32	15	5	4	1X2	46	N/A	36	45.9	0.88	19.53	20.35	45.8	
JU6H-UFADM3	32	15	5	4	1X2	46	N/A	36	45.4	0.88	19.53	20.35	45.8	
JU6H-UFAD58	32	15	5	4	1X2	46	N/A	36	45.9	0.88	19.53	20.35	45.8	
JU6H-UFADNG	32	15	5	4	1X2	46	N/A	36	45.4	0.88	19.53	20.35	45.8	
JU6H-UFADN0	32	15	5	4	1X2	46	N/A	36	45.4	0.88	19.53	20.35	45.8	
JU6H-UFADP0	32	15	5	4	1X2	46	N/A	36	45.4	0.88	24.02	20.45	45.8	
JU6H-UFADP8	32	15	5	4	1X2	46	N/A	36	45.4	0.88	24.02	20.45	45.8	
JU6H-UFADQ0	32	15	5	4	1X2	46	N/A	36	45.4	0.88	19.53	20.35	45.8	
JU6H-UFAD88	32	15	5	4	1X2	46	N/A	36	45.4	0.88	24.02	20.45	45.8	
JU6H-UFADR8	32	15	5	4	1X2	46	N/A	36	45.4	0.88	24.02	20.45	45.8	
JU6H-UFADRO	32	15	5	4	1X2	46	N/A	36	45.4	0.88	19.53	20.35	45.8	
JU6H-UFADS8	32	15	5	4	1X2	46	N/A	36	45.4	0.88	24.02	20.45	45.8	
JU6H-UFADSO	32	15	5	4	1X2	46	N/A	36	45.4	0.88	24.02	20.45	45.8	
JU6H-UFADTO	32	15	5	4	1X2	46	N/A	36	45.4	0.88	24.02	20.45	45.8	
JU6H-UFADW8	32	15	5	4	1X2	46	N/A	36	45.4	0.88	24.49	20.45	45.8	
JU6H-UFADX8	32	15	5	4	1X2	46	N/A	36	45.4	0.88	24.49	20.45	45.8	
JU6H-UFAD98	32	15	5	4	1X2	46	N/A	36	45.4	0.88	24.49	20.45	45.8	

AURORA® FIRE PUMPS

DIESEL DRIVEN VERTICAL TURBINE

JW6H CLARKE ENGINE DIMENSIONS														
MODEL	AA	AB	AF	AL	AN	CA	CB	CC	CD	CE	CS		HD	HP
											TC	CPLG		
JW6H-UFAAM8	36	17	5	4	1X2	46	N/A	36	51.7	2.9	26.50	24.45	51.1	
JW6H-UFAA80	36	17	5	4	1X2	46	N/A	36	51.7	2.9	26.50	24.45	51.1	
JW6H-UFADFO	36	17	5	4	1X2	46	N/A	36	51.7	2.9	24.49	24.45	51.1	
JW6H-UFADJO	36	17	5	4	1X2	46	N/A	36	51.7	2.9	26.50	24.45	51.1	
JW6H-UFAD70	36	17	5	4	1X2	46	N/A	36	51.7	2.9	26.50	24.45	51.1	
JW6H-UFAD80	36	17	5	4	1X2	46	N/A	36	57.7	2.9	26.50	24.45	51.1	

JX6H CLARKE ENGINE DIMENSIONS														
MODEL	AA	AB	AF	AL	AN	CA	CB	CC	CD	CE	CS		HD	HP
											TC	CPLG		
JX6H-UFADFO	40	19	5	4	1X2	54	N/A	44	54	0.34	25.73	26.45	48.9	
JX6H-UFAD60	40	19	5	4	1X2	54	N/A	44	54	0.34	25.73	26.45	48.9	
JX6H-UFADNO	40	19	5	4	1X2	54	N/A	44	54	0.34	25.73	26.45	48.9	
JX6H-UFADPO	40	19	5	4	1X2	54	N/A	44	54	0.34	25.73	26.45	48.9	
JX6H-UFAD88	40	19	5	4	1X2	54	N/A	44	54	0.34	25.73	26.45	48.9	

DP6H CLARKE ENGINE DIMENSIONS														
MODEL	AA	AB	AF	AL	AN	CA	CB	CC	CD	CE	CS		HD	HP
											TC	CPLG		
DP6H-UFAA88	36	17	5	4	1X2	46	N/A	35.50	53	2.90	24.49	24.45	46.98	
DP6H-UFAA50	36	17	5	4	1X2	46	N/A	35.50	53	2.90	24.49	24.45	46.98	
DP6H-UFAA62	36	17	5	4	1X2	46	N/A	35.50	53	2.90	24.49	24.45	46.98	
DP6H-UFAA70	36	17	5	4	1X2	46	N/A	35.50	53	2.90	24.49	24.45	46.98	

DQ6H CLARKE ENGINE DIMENSIONS														
MODEL	AA	AB	AF	AL	AN	CA	CB	CC	CD	CE	CS		HD	HP
											TC	CPLG		
DQ6H-UFAA48	36	17	5	4	1X2	46	N/A	36	51.9	2.90	25.04	24.45	49	
DQ6H-UFAA40	36	17	5	4	1X2	46	N/A	36	51.9	2.90	25.04	24.45	49	
DQ6H-UFAA50	36	17	5	4	1X2	46	N/A	36	51.9	2.90	25.04	24.45	49	
DQ6H-UFAA60	36	17	5	4	1X2	46	N/A	36	51.9	2.90	25.04	24.45	49	
DQ6H-UFAA88	36	17	5	4	1X2	46	N/A	36	51.9	2.90	25.04	24.45	49	
DQ6H-UFAA98	36	17	5	4	1X2	46	N/A	36	51.9	2.90	25.04	24.45	49	

DR8H CLARKE ENGINE DIMENSIONS														
MODEL	AA	AB	AF	AL	AN	CA	CB	CC	CD	CE	CS		HD	HP
											TC	CPLG		
DR8H-UFAA40	36	17	5	4	1X2	46	N/A	36	51.9	2.90	25.04	24.45	49	
DR8H-UFAA5G	36	17	5	4	1X2	46	N/A	36	51.9	2.90	25.04	24.45	49	
DR8H-UFAA68	36	17	5	4	1X2	46	N/A	36	51.9	2.90	25.04	24.45	49	
DR8H-UFAA62	36	17	5	4	1X2	46	N/A	36	51.9	2.90	25.04	24.45	49	

DS0H CLARKE ENGINE DIMENSIONS														
MODEL	AA	AB	AF	AL	AN	CA	CB	CC	CD	CE	CS		HD	HP
											TC	CPLG		
DS0H-UFAAN0	40	19	5	4	1X2	47	N/A	37	55.31	2.90	25.04	32.45	46.47	
DS0H-UFAA68	40	19	5	4	1X2	47	N/A	37	55.31	2.90	25.04	32.45	46.47	
DS0H-UFAA60	40	19	5	4	1X2	47	N/A	37	55.31	2.90	25.04	32.45	46.47	

DT2H CLARKE ENGINE DIMENSIONS														
MODEL	AA	AB	AF	AL	AN	CA	CB	CC	CD	CE	CS		HD	HP
											TC	CPLG		
DT2H-UFAA20	54	26	5	4	1X2	70	N/A	60	62.83	0.43	25.06	34.45	46.6	
DT2H-UFAA58	54	26	5	4	1X2	70	N/A	60	62.83	0.43	25.06	34.45	46.6	
DT2H-UFAA50	54	26	5	4	1X2	70	N/A	60	62.83	0.43	25.06	34.45	46.6	
DT2H-UFAA60	54	26	5	4	1X2	70	N/A	60	58.82	0.35	32.31	34.45	45.3	
DT2H-UFAA98	54	26	5	4	1X2	70	N/A	60	58.82	0.35	32.31	34.65	45.3	
DT2H-UFAA92	54	26	5	4	1X2	70	N/A	60	58.82	0.35	32.31	34.65	45.3	

AURORA® FIRE PUMPS

DIESEL DRIVEN VERTICAL TURBINE

Section **914** Page **213**

Date **March 2017**

Supersedes Section 914 Page 213

Dated April 2006

CFP5E CUMMINS ENGINE DIMENSIONS														
MODEL	AA	AB	AF	AL	AN	CB	CA	CC	CD	CE	CS		HD	HP
											TC	CPLG		
CFP5E-F10	28.5	13.38	6	4	1	N/A	42.5	30.5	37.9	4.5	14.87	22.5	42.64	
CFP5E-F20	28.5	13.38	6	4	1	N/A	42.5	30.5	37.9	4.5	14.87	22.5	42.64	
CFP5E-F30	28.5	13.38	6	4	1	N/A	42.5	30.5	37.9	4.5	14.87	22.5	42.64	
CFP5E-F40	28.5	13.38	6	4	1	N/A	42.5	30.5	37.9	4.5	14.87	22.5	42.64	
CFP5E-F50	28.5	13.38	6	4	1	N/A	42.5	30.5	37.9	4.5	14.87	22.5	42.64	

CFP59 CUMMINS ENGINE DIMENSIONS														
MODEL	AA	AB	AF	AL	AN	CA	CB	CC	CD	CE	CS		HD	HP
											TC	CPLG		
CFP59-F10	30.75	14.5	6	4	1	60	N/A	48	39.66	4.5	14.87	22.5	43.54	
CFP59-F15	30.75	14.5	6	4	1	60	N/A	48	39.66	4.5	14.87	22.5	43.54	
CFP59-F20	30.75	14.5	6	4	1	60	N/A	48	39.66	4.5	14.87	22.5	43.54	
CFP59-F25	30.75	14.5	6	4	1	60	N/A	48	39.66	4.5	14.87	22.5	43.54	
CFP59-F40	30.75	14.5	6	4	1	60	N/A	48	39.66	4.5	14.87	22.5	43.54	
CFP59-F50	30.75	14.5	6	4	1	60	N/A	48	39.66	4.5	14.87	22.5	43.54	

CFP7E CUMMINS ENGINE DIMENSIONS														
MODEL	AA	AB	AF	AL	AN	CA	CB	CC	CD	CE	CS		HD	HP
											TC	CPLG		
CFP7E-F10	30.75	14.5	6	4	1	60	N/A	48	48.93	2.88	14.97	22.5	43.36	
CFP7E-F20	30.75	14.5	6	4	1	60	N/A	48	48.93	2.88	14.97	22.5	43.36	
CFP7E-F30	30.75	14.5	6	4	1	60	N/A	48	48.93	2.88	14.97	22.5	43.36	
CFP7E-F40	30.75	14.5	6	4	1	60	N/A	48	47.41	4.4	16.52	22.5	43.36	
CFP7E-F50	30.75	14.5	6	4	1	60	N/A	48	47.41	4.4	16.52	22.5	43.36	
CFP7E-F60	30.75	14.5	6	4	1	60	N/A	48	47.41	4.4	16.52	22.5	43.36	

CFP83 CUMMINS ENGINE DIMENSIONS														
MODEL	AA	AB	AF	AL	AN	CA	CB	CC	CD	CE	CS		HD	HP
											TC	CPLG		
CFP83-F10	30.75	14.5	6	4	1	60	N/A	48	48.56	4.38	16.52	22.5	46.25	
CFP83-F20	30.75	14.5	6	4	1	60	N/A	48	48.56	4.38	16.52	22.5	46.25	
CFP83-F30	30.75	14.5	6	4	1	60	N/A	48	48.56	4.38	16.52	22.5	46.25	

CFP9E CUMMINS ENGINE DIMENSIONS															
RPM ONLY	MODEL	AA	AB	AF	AL	AN	CA	CB	CC	CD	CE	CS		HD	HP
												TC	CPLG		
ALL OTHERS	CFP9E-F10	30.75	14.5	6	4	1	60	N/A	48	50.63	0.15	19.85	22.5	46.26	
	CFP9E-F20	30.75	14.5	6	4	1	60	N/A	48	50.63	0.15	19.85	22.5	46.26	
	CFP9E-F30	30.75	14.5	6	4	1	60	N/A	48	50.63	0.15	19.85	22.5	46.26	
	CFP9E-F40	30.75	14.5	6	4	1	60	N/A	48	50.63	0.15	19.85	22.5	46.26	
	CFP9E-F50	30.75	14.5	6	4	1	60	N/A	48	50.63	0.15	19.85	22.5	46.26	
	CFP9E-F60	30.75	14.5	6	4	1	60	N/A	48	50.63	0.15	19.85	22.5	46.26	
1470/1760/1900	CFP9E-F20	30.75	14.5	6	4	1	60	N/A	48	50.67	0.19	19.81	22.5	46.26	
1470/1760/1900	CFP9E-F30	30.75	14.5	6	4	1	60	N/A	48	50.67	0.19	19.81	22.5	46.26	
1470/1760/1900	CFP9E-F40	30.75	14.5	6	4	1	60	N/A	48	50.67	0.19	19.81	22.5	46.26	
1470/1760	CFP9E-F50	30.75	14.5	6	4	1	60	N/A	48	50.67	0.19	19.81	22.5	46.26	
1470/1760	CFP9E-F60	30.75	14.5	6	4	1	60	N/A	48	50.67	0.19	19.81	22.5	46.26	
1900/2100	CFP9E-F50	30.75	14.5	6	4	1	60	N/A	48	50.67	0.19	19.81	22.5	46.26	
1900/2100	CFP9E-F60	30.75	14.5	6	4	1	60	N/A	48	50.67	0.19	19.81	22.5	46.26	

CFP11E CUMMINS ENGINE DIMENSIONS															
RPM ONLY	MODEL	AA	AB	AF	AL	AN	CA	CB	CC	CD	CE	CS		HD	HP
												TC	CPLG		
ALL OTHERS	CFP11E-F10	30.75	14.5	6	4	1	66	N/A	54	54.32	3.57	24.61	22.38	38.45	
	CFP11E-F20	30.75	14.5	6	4	1	66	N/A	54	54.32	3.57	24.61	22.38	38.45	
2100	CFP11E-F10	30.75	14.5	6	4	1	66	N/A	54	59.22	1.33	19.71	22.38	38.45	
2100	CFP11E-F20	30.75	14.5	6	4	1	66	N/A	54	59.22	1.33	19.71	22.38	38.45	

AURORA® FIRE PUMPS

DIESEL DRIVEN VERTICAL TURBINE

CFP15E CUMMINS ENGINE DIMENSIONS

MODEL	AA	AB	AF	AL	AN	CA	CB	CC	CD	CE	CS		HD	HP
											TC	CPLG		
CFP15E-F10	35.95	16.78	24	4	0.88	84	N/A	42	65.97	4.44	24.61	35.51	41.43	
CFP15E-F20	35.95	16.78	24	4	0.88	84	N/A	42	65.97	4.44	24.61	35.51	41.43	
CFP15E-F30	35.95	16.78	24	4	0.88	84	N/A	42	65.97	4.44	24.61	35.51	41.43	
CFP15E-F40	35.95	16.78	24	4	0.88	84	N/A	42	66.42	3.99	24.16	35.51	41.43	
CFP15E-F50	35.95	16.78	24	4	0.88	84	N/A	42	66.42	3.99	24.16	35.51	41.43	
CFP15E-F60	35.95	16.78	24	4	0.88	84	N/A	42	66.42	3.99	24.16	35.51	41.43	
CFP15E-F70	35.95	16.78	24	4	0.88	84	N/A	42	66.42	3.99	24.16	35.51	41.43	

CFP23E CUMMINS ENGINE DIMENSIONS

MODEL	AA	AB	AF	AL	AN	CA	CB	CC	CD	CE	CS		HD	HP
											TC	CPLG		
CFP23E-F10	53.48	25.5	6	6	0.88	108	48	96	80.02	2.25	25	34.5	63.5	
CFP23E-F15	53.48	25.5	6	6	0.88	108	48	96	80.02	2.25	25	34.5	63.5	
CFP23E-F20	53.48	25.5	6	6	0.88	108	48	96	80.02	2.25	25	34.5	63.5	
CFP23E-F25	53.48	25.5	6	6	0.88	108	48	96	80.02	2.25	25	34.5	63.5	
CFP23E-F30	53.48	25.5	6	6	0.88	108	48	96	80.02	2.25	25	34.5	63.5	
CFP23E-F35	53.48	25.5	6	6	0.88	108	48	96	80.02	2.25	25	34.5	63.5	
CFP23E-F40	53.48	25.5	6	6	0.88	108	48	96	80.02	2.25	25	34.5	63.5	
CFP23E-F50	53.48	25.5	6	6	0.88	108	48	96	80.02	2.25	25	34.5	63.5	
CFP23E-F60	53.48	25.5	6	6	0.88	108	48	96	80.02	2.25	25	34.5	63.5	
CFP23E-F70	53.48	25.5	6	6	0.88	108	48	96	80.02	2.25	25	34.5	63.5	

CFP30E CUMMINS ENGINE DIMENSIONS

MODEL	AA	AB	AF	AL	AN	CA	CB	CC	CD	CE	CS		HD	HP
											TC	CPLG		
CFP30E-F10	37.88	17.5	1.63	6	0.88	95.38	67.5	92.13	RTF	RTF	RTF	26	57.86	
CFP30E-F20	37.88	17.5	1.63	6	0.88	95.38	67.5	92.13	RTF	RTF	RTF	26	57.86	
CFP30E-F30	37.88	17.5	1.63	6	0.88	95.38	67.5	92.13	RTF	RTF	RTF	26	57.86	
CFP30E-F40	37.88	17.5	1.63	6	0.88	95.38	67.5	92.13	RTF	RTF	RTF	26	57.86	

CFP50 CUMMINS ENGINE DIMENSIONS

MODEL	AA	AB	AF	AL	AN	CA	CB	CC	CD	CE	CS		HD	HP
											TC	CPLG		
CFP50-F1	82.26	39.75	10	4	1	130	N/A	36.67	120.8	40.24	36.55	32	58.88	
CFP50-F2	82.26	39.75	10	4	1	130	N/A	36.67	120.8	40.24	36.55	32	58.88	
CFP50-F3	82.26	39.75	10	4	1	130	N/A	36.67	120.8	40.24	36.55	32	58.88	
CFP50-F4	82.26	39.75	10	4	1	130	N/A	36.67	120.8	40.24	36.55	32	58.88	
CFP50-F10	82.26	39.75	10	4	1	130	N/A	36.67	120.8	40.24	36.55	32	58.88	
CFP50-F20	82.26	39.75	10	4	1	130	N/A	36.67	120.8	40.24	36.55	32	58.88	
CFP50-F30	82.26	39.75	10	4	1	130	N/A	36.67	120.8	40.24	36.55	32	58.88	
CFP50-F40	82.26	39.75	10	4	1	130	N/A	36.67	120.8	40.24	36.55	32	58.88	