

MYERS® DP SERIES

High Pressure Reciprocating Plunger Pumps

Designed with Strength and Versatility

The DP Series plunger pump adds a new dimension of rugged versatility to Pentair's line of Myers® high pressure industrial pumps. In one power end, two fluid ends, the DP offers seven interchangeable plunger and seal packages, allowing complete hydraulic coverage between 1200 psi/120 gpm and 5500 psi/27 gpm. The DP handles liquids of PH4~11, up to 180°F (82°C) with a maximum inlet pressure of 100 psi. Optimum flow and pressure are easily converted, even in the field, by changing the plunger and seal kit. Two sets of different valve seats with different flow areas (valves A and B) fit into the same valve deck and are also interchangeable.

The DP Series combine Pentair's manufacturing expertise and understanding of applications to provide a pump with the strength and versatility for any demanding high pressure job.

Dimensional Data (For estimating only)

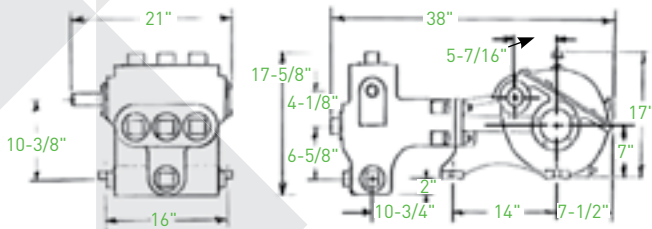

Product Specifications

Product Specifications	
Gear Reduction Ratio	3.95 to 1
Temperature Rating °F (°C)	180 82
Plunger Stroke	3.750" 95.25 mm
Suction Size (NPT)	3" 76.20 mm
Discharge Size*	1-1/2" 38.10 mm
Input Shaft	1-5/8" 41.3 mm
Keyway	3/8" x 3/16" 9.53 mm x 4.76 mm
Weight	725 lbs. 328.8 kg

*Discharge Part Connections (both sides)
SAE 1-1/2 Hydraulic 4 Bolt Flange .3000# for Fluid End A
SAE 1-1/2 Hydraulic 4 Bolt Flange .6000# for Fluid End B

Pump Performance*

Catalog Number***	Maximum Rated Capacity GPM (LPM)	Maximum Rated Pressure psi (Bar)	Maximum Rated Speed RPM/SPM	Plunger Size Inch (mm)	Maximum HP (kW)	Valve** (Set)	Fluid End Material	Fluid End Size
DP120-12	120 (454)	1,200 (82.7)	1800/456	2-5/8 (66.7)	99 (73.9)	A	Ductile Iron	A
DP90-18	88 (333)	1,700 (117.2)	1800/456	2-1/4 (57.2)	103 (76.8)	A	Ductile Iron	A
DP85-20	85 (322)	2,000 (137.9)	1800/456	2-1/4 (57.2)	117 (87.2)	A	Ductile Iron	A
DP80-20	79 (299)	2,000 (137.9)	1800/456	2-1/8 (54.0)	108 (80.5)	A	Ductile Iron	A
DP70-22	70 (265)	2,150 (148.3)	1800/456	2 (50.8)	103 (76.8)	A	Ductile Iron	A
DP55-28	53 (201)	2,800 (193.1)	1800/456	1-3/4 (44.5)	103 (76.8)	B	Ductile Iron	B
DP40-38	40 (151)	3,800 (262.1)	1800/456	1-1/2 (38.1)	102 (76.1)	B	Ductile Iron	B
DP28-55	27 (102)	5,500 (379.3)	1800/456	1-1/4 (31.8)	103 (76.8)	B	Ductile Iron	B

*Pump performance data are based upon 100% volumetric efficiency & 85% overall efficiency. ** Pump performance based on valve listed. ***Catalog number listed does not define maximum rated capacity and pressure.

Fluid-End Components

1. Cylinder body of high-strength ductile iron.
2. Tungsten carbide coated, stainless steel plungers are superhard, nonscoring, with ground smooth surface of 12u.
3. High pressure plunger seals are spring-loaded, self-lubricated, braided packing where strength, lubricating qualities and heat dissipation are needed for various applications.
4. Seal housing of aluminum-bronze features easy and quick replacement of seals.
5. Spring-loaded center post valves have acetel valves and stainless steel seats.
6. Valve caps of ductile iron/stainless steel Buna-N O-ring seals and backup ring. Valves can be serviced individually.
7. Suction and discharge located for easy service. Large threaded suction openings on sides and front. Discharge openings are tapped.

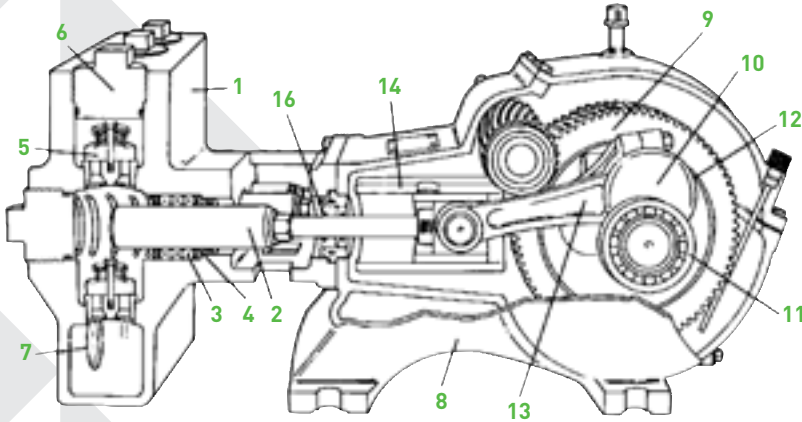

Power-End Components

8. Gear case of rugged cast iron protects the gears and serves as oil reservoir for continuous lubrication. Cover section quickly removable for easy service.
9. Pinion and main gear are helical cut and machined from high-strength alloy steel, and can rotate in either direction. Integral pinion shaft is also machined from high-strength alloy steel.
10. Automotive type crankshaft is forged heat-treated alloy steel.
11. Main bearings feature tapered roller bearings.
12. Crankshaft journal bearings are automotive type, steel-backed inserts.
13. Connecting links are ductile iron with replaceable bronze wrist-pin bearings. Wrist-pins are press-fitted into crossheads.
14. Crossheads/"pony" rods: Heavy-duty ductile iron crossheads "pony" rods are smoothly ground and highly-polished stainless steel, threaded and pinned axially to crosshead.
15. Continuous splash lubrication is provided during either direction of rotation.
16. Oil seals for "pony" rods are designed for quick and easy replacement without taking the fluid end off.

Horsepower Requirements

DP120-12		Horsepower Required For:					
GPM	RPM	200 psi	400 psi	600 psi	800 psi	1000 psi	1200 psi
66.7	1000	9.2	18.3	27.5	36.6	45.8	54.9
80.1	1200	11.0	22.0	33.0	44.0	55.0	66.0
93.4	1400	12.8	25.6	38.5	51.3	64.1	76.9
116.8	1750	16.0	32.1	48.1	64.1	80.2	96.2
120.1	1800	16.5	33.0	49.5	65.9	82.4	98.9

DP90-18		Horsepower Required For:					
GPM	RPM	700 psi	900 psi	1100 psi	1300 psi	1500 psi	1700 psi
49.0	1000	23.5	30.3	37.0	43.7	50.4	57.2
58.8	1200	28.3	36.3	44.4	52.5	60.5	68.6
68.6	1400	33.0	42.4	51.8	61.2	70.6	80.0
85.7	1750	41.2	52.9	64.7	76.5	88.2	100.0
88.2	1800	42.4	54.5	66.6	78.7	90.8	102.9

DP85-20		Horsepower Required For:					
GPM	RPM	900 psi	1100 psi	1300 psi	1500 psi	1700 psi	2000 psi
49.0	1000	30.3	37.0	43.7	50.4	57.2	67.3
58.8	1200	36.3	44.4	52.5	60.5	68.6	80.7
68.8	1400	42.5	51.9	61.2	70.8	80.3	94.4
85.8	1800	53.0	64.8	78.4	88.3	100.1	117.8

DP80-20		Horsepower Required For:					
GPM	RPM	900 psi	1100 psi	1300 psi	1500 psi	1700 psi	2000 psi
43.7	1000	27.0	33.0	39.0	45.0	51.0	60.0
52.5	1200	32.4	39.6	46.8	54.1	61.3	72.1
61.2	1400	37.8	46.2	54.6	63.0	71.4	84.0
76.5	1750	47.3	57.8	68.3	78.8	89.3	105.0
78.7	1800	48.6	59.4	70.2	81.0	91.8	108.0

DP70-22		Horsepower Required For:					
GPM	RPM	1150 psi	1350 psi	1550 psi	1750 psi	1950 psi	2150 psi
38.7	1000	30.5	35.9	41.2	46.5	51.8	57.1
46.5	1200	36.7	43.1	49.5	55.9	62.2	68.6
54.2	1400	47.8	50.2	57.7	65.1	72.5	80.0
67.8	1750	53.5	62.8	72.1	81.4	90.7	100.1
69.7	1800	55.0	64.6	74.2	83.7	93.3	102.9

DP55-28		Horsepower Required For:					
GPM	RPM	1800 psi	2000 psi	2200 psi	2400 psi	2600 psi	2800 psi
29.7	1000	36.7	40.8	44.8	48.9	53.0	57.1
35.6	1200	44.0	48.9	53.8	58.6	63.5	68.4
41.5	1400	51.3	57.0	62.7	68.4	74.1	79.8
51.9	1750	64.1	71.2	78.4	85.5	92.6	99.7
53.4	1800	66.0	73.3	80.6	88.0	95.3	102.6

- Horsepower required is based upon 85% overall efficiency.
- Displacement is based on 100% volumetric efficiency.
- Formula (1) $HP\ required = \frac{GPM \times psi}{1457}$ or $kW = \frac{LPM \times BAR}{511}$ (electric brake)

(2) $Expected\ GPM = Rated\ GPM \times \frac{Working\ RPM}{Rated\ RPM}$ or
 $Expected\ LPM = Rated\ LPM \times \frac{Working\ RPM}{Rated\ RPM}$ or
 $Motor\ Sheave = Pump\ Sheave \times \frac{Pump\ RPM}{Motor\ RPM}$
O. D. size O. D. size

DP40-38		Horsepower Required For:					
GPM	RPM	2800 psi	3000 psi	3200 psi	3400 psi	3600 psi	3800 psi
21.8	1000	41.9	44.9	47.9	50.9	53.9	56.9
26.1	1200	50.2	53.7	57.3	60.9	64.5	68.1
30.5	1400	58.6	62.8	67.0	71.2	75.4	79.6
38.1	1750	73.2	78.5	83.7	88.9	94.1	99.4
39.5	1800	75.3	80.7	86.1	91.5	96.9	102.2

DP28-55		Horsepower Required For:					
GPM	RPM	4500 psi	4700 psi	4900 psi	5100 psi	5300 psi	5500 psi
15.1	1000	46.6	48.7	50.8	52.9	54.9	57.0
18.2	1200	56.2	58.7	61.2	63.7	66.2	68.7
21.2	1400	65.5	68.4	71.3	74.2	77.1	80.0
26.5	1750	81.9	85.5	89.1	92.8	96.4	100.0
27.2	1800	84.0	87.7	91.5	95.2	98.9	102.7



1101 MYERS PARKWAY, ASHLAND, OH 44805
 WWW.FEMYERS.COM
 PH: 855-274-8948

490 PINEBUSH ROAD, UNIT 4, CAMBRIDGE, ONTARIO N1T 0A5
 WWW.FEMYERS.COM
 PH: 800-387-4386 ORDERS FAX: 888-606-5484

Myers® is a registered trademark of Pentair.

Because we are continuously improving our products and services, Pentair reserves the right to change specifications without prior notice.
 K3339 06/20/17 © 2017 Pentair Ltd. All Rights Reserved.