

FAIRBANKS NIJHUIS™ MODELS 1800-1900

ENGINEERING SPECIFICATIONS CENTRIFUGAL FIRE PUMPS

Section 910 Page 61

Date April 2006

Supersedes Section 910 Page 61

Dated June 1994

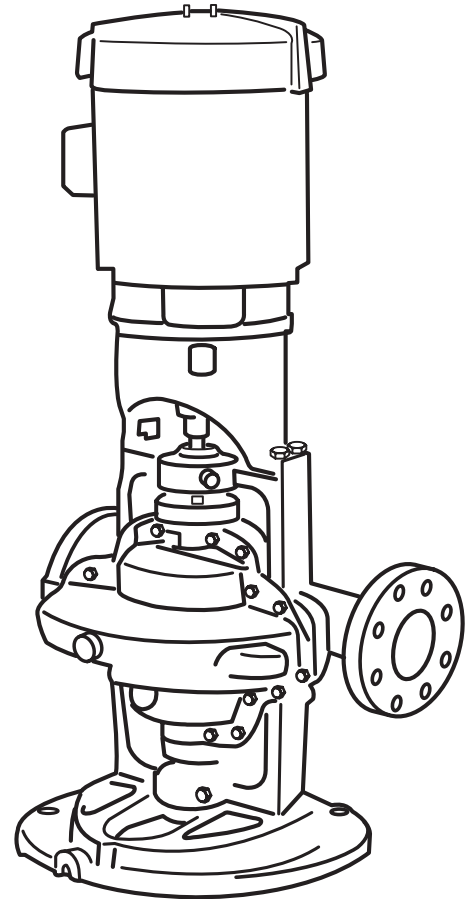
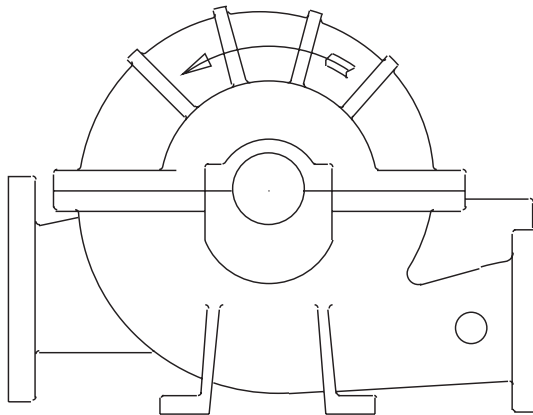
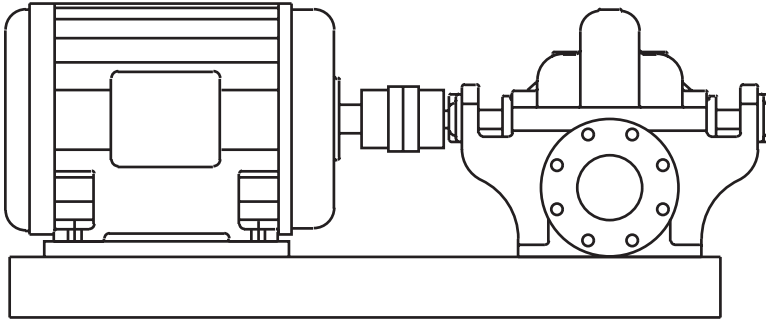

Furnish and install where shown on plans _____ Fairbanks Fire Pump System(s) complete with pump, driver, controller and accessories. The pumping unit shall be listed by Underwriters' Laboratories, Inc. and/or shall be fully approved by the Associated Factory Mutual Fire Insurance Companies, where applicable. The pumping unit shall meet all requirements of the National Fire Protection Association Pamphlet No.20. The Fire Pump shall be designed to deliver _____ G.P.M. when operating at _____ PSIG. The pump shall also deliver not less than 150% of rated capacity at a pressure not less than 65% of rated pressure. The shut off pressure shall not exceed 140% of rated pressure. Suction pressure is _____ PSIG. The pump shall operate at a maximum synchronous speed of _____ R.P.M.

The Fire Pump shall be (one of the following):

(A) FAIRBANKS MODEL 1800 HORIZONTAL BASE MOUNTED size _____ - 18 _____ horizontal split case, bronze fitted, SINGLE STAGE, double

suction centrifugal pump.

(B) FAIRBANKS MODEL 1900 HORIZONTAL BASE MOUNTED size _____ - 19 _____ horizontal split case, bronze fitted, TWO STAGE, single suction, centrifugal pump.

The driver shall be a horizontal, foot mounted, open drip-proof (or T.E.F.C.), ball bearing type, AC, induction, squirrel cage motor: wound for _____ volts, 3 phase, 60 (50) Hertz. The motor shall be of such capacity that 115% of the full-load ampere rating shall not be exceeded at any condition of pump load. Locked rotor current shall not exceed the values specified in NFPA Pamphlet No.20.

FAIRBANKS NIJHUIS™ MODELS 1800-1900

ENGINEERING SPECIFICATIONS

CENTRIFUGAL FIRE PUMPS

Pump and motor shall be mounted on a common baseplate of steel (or optional with drip rim). Pump and motor shall be checked for alignment after the pump base has been installed and grouted in place.

C. FAIRBANKS MODEL 1800 VERTICAL BASE MOUNTED size ____-18__ - ____ vertical splitcase, vertical mounted, bronze fitted, SINGLE STAGE double suction, centrifugal pump.

The driver shall be a vertical, open drip-proof (or T.E.F.C.), ball bearing type, AC, induction, squirrel cage "P" face motor: wound for ____ volts, 3 phase, 60 (50) Hertz. The motor shall be of such capacity that 115% of the full-load ampere rating shall not be exceeded at any condition of pump load.

Locked rotor current shall not exceed the values specified in NFPA Pamphlet No.20.

The mounting feet of the pump shall be machined perpendicular to the shaft. The pump shall be bolted to an extra heavy cast iron drip rim ring base. The top of the pump shall be machined to receive the motor mounting bracket. The mounting bracket shall be machined with registered fits to align pump and motor.

Casings shall be of cast iron having a minimum tensile strength of 35,000 P.S.I. Bearing housing supports, and suction and discharge flanges shall be integrally cast with the lower half of the casing. Removal of the upper half of the casing must allow the rotating element to be removed without disconnecting the suction and discharge flanges.

Impellers shall be of the enclosed type and shall be of vacuum cast bronze. Impellers shall be dynamically balanced, keyed to the shaft, and held in place with threaded shaft sleeves.

The pump shaft shall be made of SAE 1045 Steel or equal, accurately machined to give a true running rotating element. Shaft shall be protected by bronze sleeves which are key locked and threaded so that the sleeves tighten with the rotation of the shaft. An o-ring shall seal between the impeller hub and the shaft sleeve to protect the pump shaft.

Pump shall be equipped with renewable bronze casing rings so designed that hydraulic pressure will seat them against a shoulder in the pump case around the full periphery of the wearing ring. The wearing rings will be locked by dowelling to prevent rotation. The rotating element uses heavy duty grease lubricated ball bearings and shall be equipped with water slingers. Bearing housings shall be so designed to flush lubricant through the bearing.

All pumps where the suction pressure is expected to average 40 P.S.I. or below, shall be provided with a lantern ring connected to the pressure side of the pump by a cored passage in the parting flange of the pump. Stuffing boxes shall be equipped with split bronze packing glands designed for easy removal for packing inspection and maintenance.

The fire pump unit shall include the following accessories, as required by NFPA standards (depending on the conditions under which the pumps are to be installed).

- | | |
|--|--------------|
| 1. Flow metering device | _____ |
| 2. Eccentric tapered suction reducer | _____ |
| 3. Concentric tapered discharge increaser | _____ |
| 4. Discharge tee | _____ |
| 5. Base elbow | _____ |
| 6. Hose valves | _____ |
| 7. Caps and chains | _____ |
| 8. Hose valve header | _____ |
| 9. Blind flange | _____ |
| 10. Pressure gauges | <u> X </u> |
| 11. Main relief valve (mandatory for engine drives) | _____ |
| 12. Circulation relief valve | <u> X </u> |
| 13. Relief cone - enclosed (mandatory for engine drives) | _____ |
| 14. Automatic air release valve | <u> X </u> |
| 15. Splash shield (electric drive only) | _____ |
| 16. Balldrip valve | _____ |
| 17. Coupling guard | <u> X </u> |

ENGINEERING SPECIFICATIONS

CENTRIFUGAL FIRE PUMPS

The Fire Pump motor control shall be U .L. Listed and/ or F.M. Approved, where applicable. It shall be completely assembled, wired and tested by the control manufacturer before shipment from the factory, and shall be labeled "Fire Pump Controller." The controller shall be located as close as practical and within sight of the motor. The controller shall be so located or protected that it will not be injured by water escaping from the pump or connections. The controller shall be of the combined manual and automatic, (across-the-line) (primary resistor) (partwind) (limited service) (wye delta) type, and shall be complete with:

1. Disconnect switch - externally operable, quick-break type.
2. Circuit breaker - time delay type with trips in all phases set for 300% of the motor full-load current. The interrupting capacity of circuit breaker shall be _____ asymmetrical amperes.
3. Motor starter - across-the-line type capable of being energized automatically through the pressure switch or manually by means of an externally operable handle.
4. Pressure switch set to cut in at _____ p.s.i.g. and out at _____ p.s.i.g.
5. Running period timer - set to keep motor in operation, when started automatically, for a minimum period of one minute for each 10 HP motor rating, but not to exceed 7 minutes.
6. Pilot lamp - to indicate circuit breaker closed and power available.
7. Ammeter test link and voltmeter test studs.
8. Alarm relay - to energize an audible or visible alarm through an independent source of power to indicate circuit breaker open or power failure.
9. Manual selection station - a two position station shall be provided on the enclosure marked "Automatic" and "Non-automatic."
10. Means shall be provided on the Controller to operate an alarm signal continuously while the pump is running.

Control equipment shall meet all requirements of NFPA No.20.

ENGINE DRIVE

The Fire Pump shall be driven by a U .L. Listed and F.M. Approved diesel engine. The engine shall conform to the requirements of NFPA Pamphlet No.20 and be approved for Fire Pump use. The rated speed shall not exceed _____ RPM and shall develop _____ H.P. to drive the pump. Reserve H.P. shall be as stipulated in Pamphlet No.20 when the unit is operating at _____ ft. above sea level in an ambient temperature not greater than _____ degrees F.

The engine shall be of the self-contained open type mounted on a suitable base with the following minimum accessories, plus any others that may be necessary by local requirements.

1. Dual battery set sized to NFPA Pamphlet No.20 requirements with electrolyte shipped in separate containers, rack and cables **X**
2. Dual battery charger of proper type for batteries used (included in U.L. Listed/F.M. Approved controller) **X**
3. Electric starter with suitable generator and voltage regulator **X**
4. Engine water pump **X**
5. Heat exchanger cooling system **X**
6. Water cooled or ceramic blanketed exhaust manifold **X**
7. Lubricating oil pump and filter **X**
8. Speed governor **X**
9. Fuel injection system **X**
10. Air cleaner **X**
11. Stubshaft **X**
12. Fuel Pump **X**
13. Engine Jacket Pre-heater **X**
14. Oil Emersion Heater **X**
15. Proper instrument panel complete with engine run warning light, water temperature gauge, oil pressure gauge, ammeter, totalizing type tachometer and hour meter **X**
16. Commercial Grade Muffler **X**
17. Cooling water line for the engine heat exchanger assembly **X**
18. Flexible exhaust connectors **X**

All engine wiring for automatic operation shall terminate in a proper junction box to permit field connection to a separate control panel.

FAIRBANKS NIJHUIS™ MODELS

1800-1900

ENGINEERING SPECIFICATIONS

CENTRIFUGAL FIRE PUMPS

FUEL SYSTEM

A suitable fuel system for the diesel engine shall be furnished. It must be in accordance with NFPA Pamphlet No.20, and shall include a _____gallon above surface storage tank. Flexible fuel connectors, combination vent-flash arrestor and fill cap shall be included.

AUTOMATIC ENGINE CONTROL PANEL

The automatic engine control panel shall be approved for fire pump service and shall meet the requirements of NFPA Pamphlet No. 20. The panel shall be of the floor-mounted type, and enclosed in a moisture and dust tight housing. A combination manual and automatic type controller with "Manual-Off-Automatic" selector switch shall be provided also, a 115 volt single phase power failure relay or a pressure switch, which will (when the system drops to _____psig) activate all electrical circuits to automatically start the engine.

Should the engine fail to start after the required cranking cycles, the controller shall disconnect the starting circuit and activate an alarm system using lights and buzzer or bell. "Low oil pressure" and "high jacket-water temperature" shall also be indicated by a suitable alarm system. The engine shall not shut down if either of these conditions occurs during an operating cycle.

The engine shall be started automatically by the controller at least once a week and operate a minimum of 30 minutes. An appropriate timing arrangement shall determine the day and hour of this test.

Starting the engine by a fire alarm relay, deluge valve relay, or remote push-button station shall be included in the controller circuit.

In the event the pump, engine and control are in an unattended area, a remote alarm panel shall be furnished as per NFPA Pamphlet No.20.

TESTS

The pump and electric motor (or engine) shall be thoroughly shop-tested by the respective manufacturers as required by NFPA Pamphlet No.20. The control panel shall also be tested as a unit. All such tests shall be conducted prior to shipment.

The pump, driver, controller and all accessories shall be purchased under a unit contract. The pump shall be given a complete performance test with POSITIVE SUCTION PRESSURE. A certified performance curve shall be prepared and submitted. Pumps shall also be hydrostatically tested to twice the shut off pressure, but in no case less than 250 lbs. per sq. inch.

In the case of diesel drives, the pump manufacturer shall perform a second pump operational test as a unit with the job engine. Test data shall be furnished.

The pump manufacturer shall assume unit responsibility and shall provide the services a factory trained representative to supervise and/or be available to conduct final field acceptance tests.

FIRE PUMPS

Fire pumps for industrial plants and similar locations have a range of capacities from 500 to 4,500 gallons per minute. Their principal use is to make available large amounts of water for fire protection. They may take suction from a public main simply to increase the pressure available from such a source, but they are more often provided with their own reservoirs, suction tanks or wells, making the plant independent of piped water from public systems.

Pumps, which are used to make up pressure deficiencies in water supplies (which otherwise are of adequate volume), are referred to as "booster" pumps. These are often installed in a by-pass so that the city or other supply may be used directly when desired. Such booster pumps have commonly been of 500 to 1,000 gallons per minute capacity.

Small pumps known as "special fire service" pumps are sometimes used in situations where a limited amount of water is available (as from a city main) and it is necessary to avoid drafting too heavily from it. At zero lift, their maximum capacity should not exceed 130 percent of rated capacity. The capacities of such pumps are ordinarily 150, 200, 300 or 450 gallons per minute. Such special fire service pumps may also be used as booster pumps where local conditions make such small pumps acceptable.

Currently, most fire pumps installed are centrifugal types because these lend themselves readily to electric; steam turbine or internal combustion engine drive, and may be readily arranged for automatic operation.

PUMP CHARACTERISTICS

Permanently installed fire pumps may be designed to deliver their rated capacity against a specified head. This is usually 231 feet or 100 pounds per square inch, but in any case may be set according to the expected service demands. Fire pumps are required to deliver 150 percent of rated capacity at not less than 65 percent of the rated pressure. This produces a "flat" characteristic curve for these pumps. This is in contrast to the performance characteristics used for automobile pumps and industrial pumps.

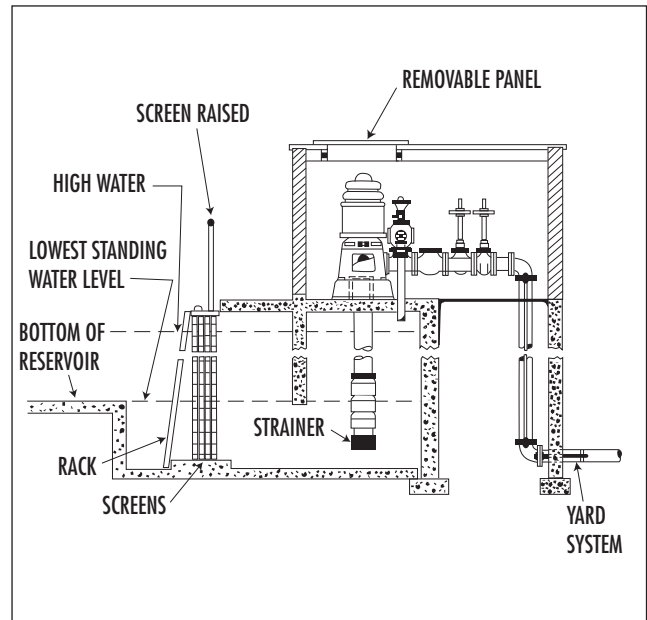

VERTICAL SHAFT TURBINE-TYPE FIRE PUMP INSTALLATION IN WET PIT

This is favored arrangement when the fire pump must take suction under a lift. Trash rack has 1/2-inch flat or 3/4-inch round steel bars spaced 2 to 3 inches apart. Double screens, one shown raised, one in position.

PUMP SUCTION (HORIZONTAL PUMP WITH WATER SUPPLY UNDER A POSITIVE HEAD)

Including allowance for velocity and friction loss through all suction pipe and fittings, the size of the suction pipe shall be such that the total equivalent operating suction lift will not exceed 15 feet. The suction pipe must be tight and not be excessively long. The inspector will find that many pump troubles are traceable to improper suctions. Workmen do not always make suction pipes tight. An uneven grade may leave high spots where an air pocket may break the suction. A long suction pipe introduces excessive friction loss. Each pump should have a separate suction pipe.

PRIMING

The suction pipe and pump casing must be full of water for the pump to work. The pump casing must be provided with an automatic air release valve or umbrella cock to allow evacuation of air.

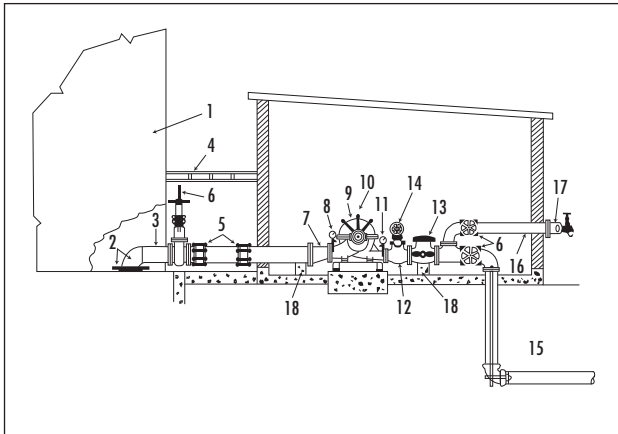

ARRANGEMENT OF CENTRIFUGAL FIRE PUMP WITH WATER ALWAYS UNDER A HEAD

1. Aboveground suction tank.
2. Entrance elbow and square vortex plate, 4 by 4 feet, 4 inches above bottom of tank.
3. Suction pipe.
4. Frostproof casing.
5. Flexible couplings.
6. Valves, indicating type.
7. Eccentric reducer.
8. Suction gage.
9. Horizontal fire pump.
10. Umbrella cock or automatic air release.
11. Discharge gage.
12. Reducing tee.
13. Discharge check valve.
14. Relief valve, if required.
15. Discharge pipe.
16. Drain valve or ball drip.
17. Hose valve manifold with hose valves.
18. Pipe supports.

INSPECTION OF FIRE PUMPS

A. Trace water from its source to the pump. Water meters on supplies from mains should not be type with excessive friction loss. Meters, or any fish traps with them, should not be obstructed. Wells on vertical pumps should be straight and of adequate diameter. Suction pipe from a large uncovered reservoir, or from a pond or river supply, should get only water free from sediment and foreign material. Examine screens at intakes and inquire what arrangements are for their periodic cleaning.

B. Inspect the pump house or pump room. Note combustible construction or any storage of combustible materials in the pump room. Consider the location of pump house or pump room noting if it might be made inaccessible or the power supplies made unreliable by a fire or by flood waters. Determine adequacy of pump room ventilation to help prevent dampness.

C. Note size and type of pump and arrangement of control devices. Note size of suction and discharge connections and pipes. Give length of suction pipe and the head in feet under which water is received by the pump, or the lift in feet.

D. Ask for any records kept of weekly running tests made both to check operation of the pump and the operation of manual and automatic starting, stopping and general control equipment provided as part of the installation. See the results of the last annual full capacity test.

E. Fire pumps are designed for relatively infrequent use, but must be able to perform satisfactorily even after standing idle for some time. Note whether the conditions generally make this possible. The pump should not be used for any other pumping service. It should be possible for an excited and perhaps unskilled person to start the pump. Note the extent to which employees show familiarity with the operation of the pump.

CENTRIFUGAL FIRE PUMPS

Following are some of the important features to cover in an inspection.

There are many other details and for these consult CENTRIFUGAL FIRE PUMPS, NFPA No.20, which covers the common method of driving; electric motors, steam turbines, gasoline (installations prior to adoption of 1974 edition of NFPA No.20) and diesel engines.

In general, pump and driver should be provided as a unit together with all needed control equipment. There should be acceptable evidence available for the inspector that the entire assembly is properly designed, such as listing of the assembly by Underwriters' Laboratories, Inc., Underwriters' Laboratories of Canada or Factory Mutual Research Corporation.

CENTRIFUGAL FIRE PUMP INSTALLATIONS										
PUMP SIZE, GPM	500	750	1,000	1,500	2,000	2,500	3,000	3,500	4,000	4,500
SIZE OF DISCHARGE PUMP, INCH (MIN)	5	6	6	8	10	10	12	12	12	14
SIZE OF SUCTION PUMP, INCH (MIN)	5	6	8	8	10	10	12	12	14	16
SIZE OF RELIEF VALVE, INCH	3	4	4	6	6	6	8	8	8	8
NUMBER OF HOSE VALVES	2	3	4	6	6	8	12	12	16	16

A. Check manufacturer's head-delivery, efficiency and brake horsepower curves against the conditions of service to determine general suitability of the pump.

B. Note nameplate data on electric motors to determine suitability.

C. Investigate reliability of the electric power supply. There should be at least one reliable source from stations not subject to fire damage and preferably two independent circuits to the pump house. Underground circuits are best, but in any case arrangements should be such that possible interruptions by fire, wind or high water are minimized.

D. Look for suitable disconnecting means for electric circuits and proper overcurrent protection. Inspect the transformer installation.

E. Examine starting and stopping and general control arrangements. Note whether manual, or combined automatic and manual. Where a motor driven centrifugal pump is the sole sprinkler supply, record any central station supervisory service providing positive indications at the central station that the pump has operated normally.

F. Location of control equipment should be within sight of the pump. Electrical apparatus should be protected against leakage from the pump and other moisture. Control equipment should be in cabinets. Backs of cabinets should be easily accessible.

G. Investigate the steam supply to turbines driving pumps.

H. If internal combustion engine drive is provided, investigate ventilation of the pump room. Gasoline engines should not be installed in depressed pump rooms where gasoline vapors, which are heavier than air, may accumulate. Inspect the storage of main supply of gasoline or oil fuel. Ask if gasoline supply is fresh -not more than a year old. Note if exhaust pipe is run to a safe place outside. Flexible connection in exhaust pipe at engine should allow for pipe expansion. Storage batteries should be properly maintained and necessary spare parts kept on hand.

STEAM SUPPLIES FOR PUMPS

A. Note location of boiler house or boiler room. It should be cut off from remainder of property and from probable interference by fire. The location should be above high flood water .

B. Note number and horsepower of boilers. There should be a minimum of two boilers providing steam for fire pumps. Horsepower of boilers on which steam is regularly maintained should be sufficient to operate all fire pumps to capacity.

For reciprocating steam pumps the boiler should be able to keep 50 pounds up at all times. Turbines may require pressures 40 to 70 pounds.

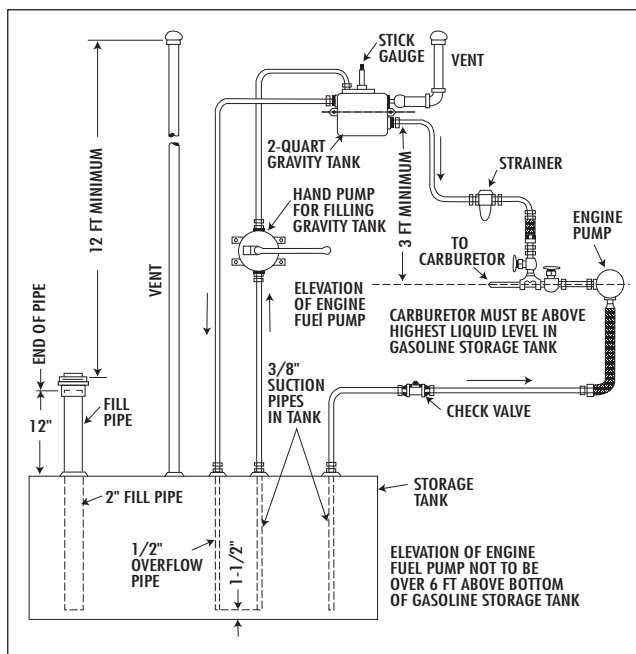

GASOLINE ENGINE FUEL SYSTEM

Schematic diagram of suitable pump feed for fuel. The valve in the line from the 2-quart tank to the carburetor is normally kept closed.

Very high pressures are not desirable and superheated steam should not be used on reciprocating type pumps. In general, reducing valves should be avoided, but see NATIONAL STANDARD STEAM FIRE PUMPS, NFPA No.21, for description of an arrangement which may be used for the fire pump supply when steam with high superheat is the supply normally available.

C. Investigate reliability of supply of water for boiler feed, which should be separate from the main water supply when possible.

D. Investigate dependability of fuel supplies to boilers, noting total amount stored on the premises. Minimum storage should be about 48 hours supply.

E. Steam piping in the boiler house should be so arranged that anyone or all boilers may be reserved for steam pump supply only.

F. Steam line to the pumps should be an independent line from header on the boiler. The main should run to the pump as directly as possible. If there are two fire pump lines, each should have a valve at the boiler and pump. Throttle valve should be of globe pattern.

G. Investigate possibility of steam main or mains being broken by falling walls or burning buildings. Mains should be installed to take care of expansion and contraction and be provided with proper traps.

H. Valves in steam lines should be open and steam should be up to the throttle valves on the pumps.

2. TESTS OF FIRE PUMPS

In even a brief or routine inspection the inspector should request that pumps be operated a few minutes at rated speed with water discharging through some convenient opening. Steam reciprocating pumps may run until water is discharging freely through the relief valve. The management of a property with a fire pump should make similar running tests weekly. It should have employees to make tests for the inspector. The inspector should not operate equipment.

On acceptance and at annual intervals, the pump should be given a complete test. The annual tests are set up to provide a complete check on the performance of the whole assembly: suction connections, pump, prime mover, steam and electric supplies. In making such tests, several lines of 2-1/2" hose, 50 to 200 feet long, are laid out from hydrants or from the pump manifold. Water is pumped and discharged through the hose lines, the amount being calculated from pitot tube gage reading at the nozzles. Inspectors should insist that nozzles be lashed at some convenient location to make the work of testing easier and avoid injuries to men holding nozzles.

CENTRIFUGAL PUMPS

A. Determine that pump is primed and casing is full of water. Interior wearing rings may be damaged by operation without water.

B. Have the pump started" observing proper method of starting for various types of drive.

C. Observe bearings for signs of overheating.

D. Observe alignment of pump and driver. Note tightness of foundation bolts.

E. Observe stuffing boxes of pump. With water seal supplied with water" a small leak at stuffing box glands is necessary.

F. Watch pressure gages. Signs of suction leaks may be indicated by flickering of gages or knocking in pump. Gage readings also may suggest that there are obstructions in the suction line" such as ice" or that screens are clogged, that well supply is inadequate" or that intakes are insufficiently immersed.

G. Have all outlets closed, including relief valve, and note that pump shuts off at the proper pressure (for horizontal shaft pumps usually not over 120 percent of rated pressure; for vertical shaft pumps 140 percent)

H. If pump is arranged for automatic as well as manual starting, have the pump started by opening a test connection.

ELECTRICALLY DRIVEN CENTRIFUGAL PUMPS

Electric pump controllers may have detailed instructions given on the controller and these should be followed. Manual starting should be repeated a number of times at each set.

STEAM TURBINE DRIVEN PUMP

A. To start pump, have steam admitted slowly at first to permit warming up of turbine casing before allowing full head of steam on turbine.

B. If pop safety valve on casing blows, have steam shut off and examine exhaust piping for closed valve or obstructed portion of piping.

C. Observe that governors maintain proper speed. Have the emergency governor valve tested by tripping it.

D. To vary speeds below rated speeds, have main throttle valve used.

INTERNAL COMBUSTION ENGINE DRIVEN PUMP.

To start pump, follow manufacturer's instructions as to starters.

FIRE PUMP START-UP AND FIELD ACCEPTANCE TEST

The following is a general outline for starting and field testing Fire Pump Systems. It is understood that requirements and methods vary depending on the location (city). Anyone becoming involved in fire pump sales, must fully understand all local requirements, within his designated territory, the NFPA-20 Pamphlet and the Factory Mutual Fire Protection Manual. A general method to follow is outlined below.

1. Be specific and complete when ordering Fire Pumps and accessories so that the necessary and correct items can be supplied.

2. Trouble can not be tolerated on the day of the field acceptance test, therefore

A. Visit the jobsite after the equipment has been delivered and check for completeness and correctness and answer any questions the contractor may have.

B. Visit the jobsite after installation and check for correctness of installation.

3. After the installation is complete and the Fire Pump System is pressurized and checked by the contractor an initial test should be conducted. This is to check the controller and motor. The test should be conducted (with contractor present if possible on engine drive systems, engine representative will be present for start-up) as follows:

A. Close all valves on discharge outlets. Check pump and motor alignment.

B. Open suction valve.

C. Check motor controller service manual and perform any necessary steps outlined, in the manual, prior to putting controller into operation. Also, read manual to understand how to operate the controller. Set controller to manual position.

D. With controller in manual position, the pump can be started. Check relief valves, be sure they are not completely closed. Start pump.

E. Adjust packing (if necessary), note if pump bearings are heating excessively; check pump RPM.

F. Completely close all relief valves. Check shut-off pressure of pump and see if the total dynamic head agrees with factory certified head/capacity curve.

G. Stop pump.

H. The jockey pump should be on line and proper system pressure maintained.

I. Set the motor controller to the automatic position.

J. Drop system pressure to below normal with test valve. The fire pump should start automatically.

4. After all is checked and equipment is operating properly arrangements can be made to perform the field acceptance test. People required to be present and forms necessary for recording the test can be obtained from the local insurance authorities.

5. Equipment necessary for field testing varies considerably in different localities. The maximum that you, as a supplier of the fire pump, should supply is:

A. Calibrated ammeter.

B. Volt meter.

C. Tachometer.

D. Pitot tube and gauge.

E. *Calibrated suction and discharge gauges with a range accuracy of 1/4%. (First three items are in your APCO-MATIC kit)

*The gauges furnished with the pump are 3% accurate and could lead to problems if used for the field acceptance test. Equipment which is necessary for the test and should be supplied by the local authorities:

1) 50 ft. of 2-1/2' hose for each hose connection on the outside hose header.

2) Play pipe with 1-3/4" nozzle for each hose.

6. Field acceptance tests will vary in all locations. The following steps are general and for electric drives. You will have to add any other requirements which might be particular to your territory:

A. Hose and play pipe should be connected to each opening of outside hose header.

B. Close discharge valve leading to building fire system.

C. Open discharge valve leading to outside hose header.

D. Suction valve should be open.

E. Close all relief valves.

F. Open one (1) outside hose valve.

G. Using pitot tube and gauge with 1-3/4" nozzle, valve should be adjusted until gauge on pitot tube reads 30 PSI, this is equal to 500 GPM.

By opening additional valves and measuring the flow to equal 500 GPM, the proper flow (500, 1000, 1500, 2000, 2500, 3000, 3500, 4000 or 4500) can be obtained. Chart 1 lists nozzle pressures and flows for various nozzle sizes.

H. Open the necessary hose valves to obtain the rated flow. Check all nozzles making sure the correct flow is maintained. Changing one valve usually changes the flow in the other hoses. When the proper flow is assured, check and record the following data:

1) Suction gauge pressure.

2) Discharge gauge pressure.

3) Check RPM with tachometer.

4) Voltage.

5) Amps (on all legs).

The panels are equipped with jacks for connecting the volt meter and ammeter.

I. Return to the nozzles and check flow to make sure it did not change. If any change is noted, re-establish the proper flow, recheck and record data. Repeat this until you are sure all necessary data is correct and recorded.

J. Adjust hose valves until a flow of 150% of rated flow is obtained. Proceed as before and record necessary data. Again, accuracy is very, very important and necessary.

K. This step applies only if required by the local authorities. It is not required by U.L. but is required by F.M. Open all hose valves full or just short of extreme cavitation by the pump. Record all data.

L. Close all hose valves completely. Make sure all relief valves are closed. Check and record all data at this shutoff (0 GPM) condition.

M. Set relief valves to proper setting.

1) System relief valve should be set slightly over maximum system pressure.

2) Casing relief valve should be set slightly under shutoff pressure of the pump.

Q. Data obtained should match the certified performance test from the factory (at 0 GPM, rate GPM, and 150% rated GPM). Average value of the highest amps recorded should not exceed the nameplate amps of motor by more than 115% (due to normal variations of test equipment, 120% may be considered acceptable).

R. If data does not agree with test, recheck your data and if necessary, retest pump. Be sure you figure total dynamic head correctly.

NOZZLE PRESS.	GPM AT VARIOUS NOZZLE SIZES					
	1-1/8	1-1/4	1-3/8	1-1/2	1-5/8	1-3/4
10	100	130	160	195	235	285
20	160	203	245	290	348	410
30	206	254	308	366	430	498
35	222	275	332	395	464	538
40	238	294	355	423	496	575
45	252	311	377	448	525	610
50	266	328	397	473	555	643
55	279	344	417	496	582	675
60	291	360	435	518	608	705
62	296	366	442	526	618	716
64	301	371	449	535	628	728
66	305	377	456	543	637	739
68	310	383	463	551	647	750
70	315	388	470	559	656	761
72	319	394	477	567	666	772
74	323	399	483	575	675	783
76	328	405	490	583	684	793
78	332	410	496	590	693	803
80	336	415	502	598	702	814
85	347	428	518	616	723	839
90	357	440	533	634	744	863
95	366	452	547	651	765	887
100	376	464	562	668	784	910
105	385	476	575	685	804	932
110	394	487	589	701	823	954
115	403	498	602	717	841	976
120	412	509	615	732	859	997