

# Performance Curve – S3S/S3SD/SB3S/SB3SD

RPM: **1750** DISCHARGE: **3"** SOLIDS: **2-1/2"**

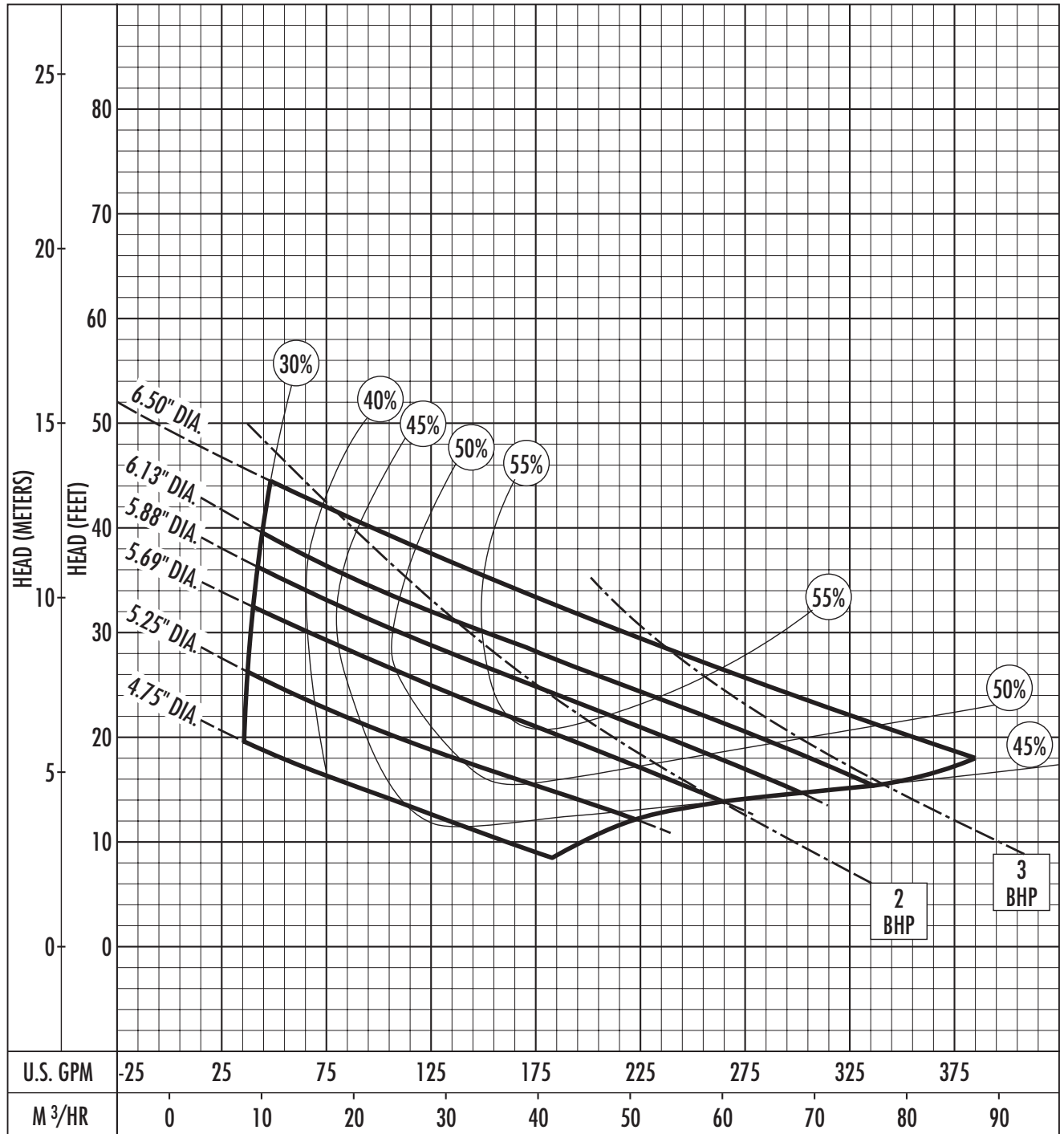

The curves reflect maximum performance characteristics without exceeding full load (Nameplate) horsepower. All pumps have a service factor of 1.2. Operation is recommended in the bounded area with operational point within the curve limit. Performance curves are based on actual tests with clear water at 70° F. and 1280 feet site elevation.

Conditions of Service:

# Performance Curve – S3SD/SB3SD

RPM: **1150** DISCHARGE: **3"** SOLIDS: **2-1/2"**

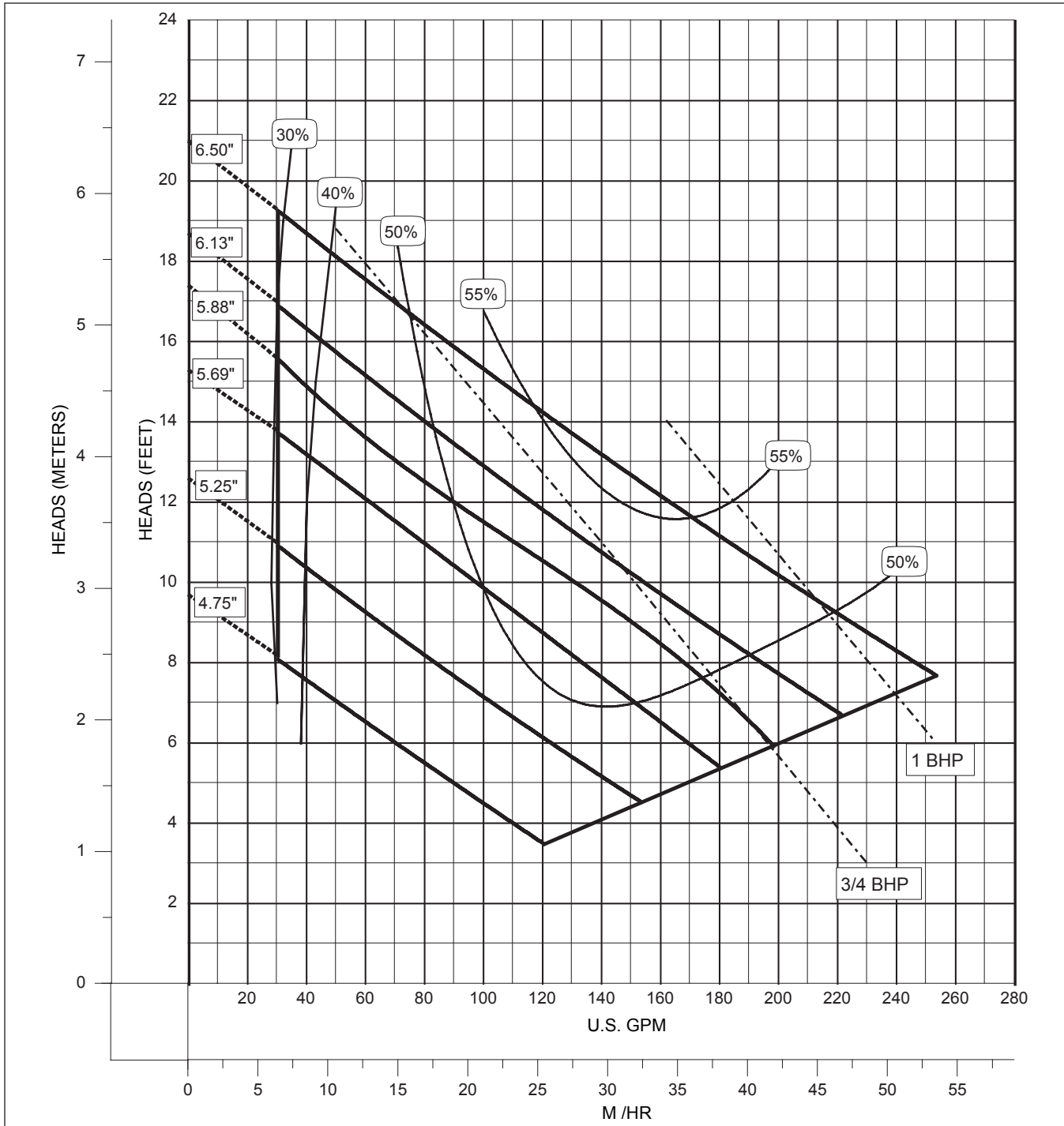

The curves reflect maximum performance characteristics without exceeding full load (Nameplate) horsepower. All pumps have a service factor of 1.2. Operation is recommended in the bounded area with operational point within the curve limit. Performance curves are based on actual tests with clear water at 70° F. and 1280 feet site elevation.

Conditions of Service:



HYDROMATIC®

GPM: \_\_\_\_\_ TDH: \_\_\_\_\_

May © 2016 Pentair plc

# Performance Curve – S4S/S4SD/SB4S/SB4SD

RPM: **1750** DISCHARGE: **4"** SOLIDS: **3"**

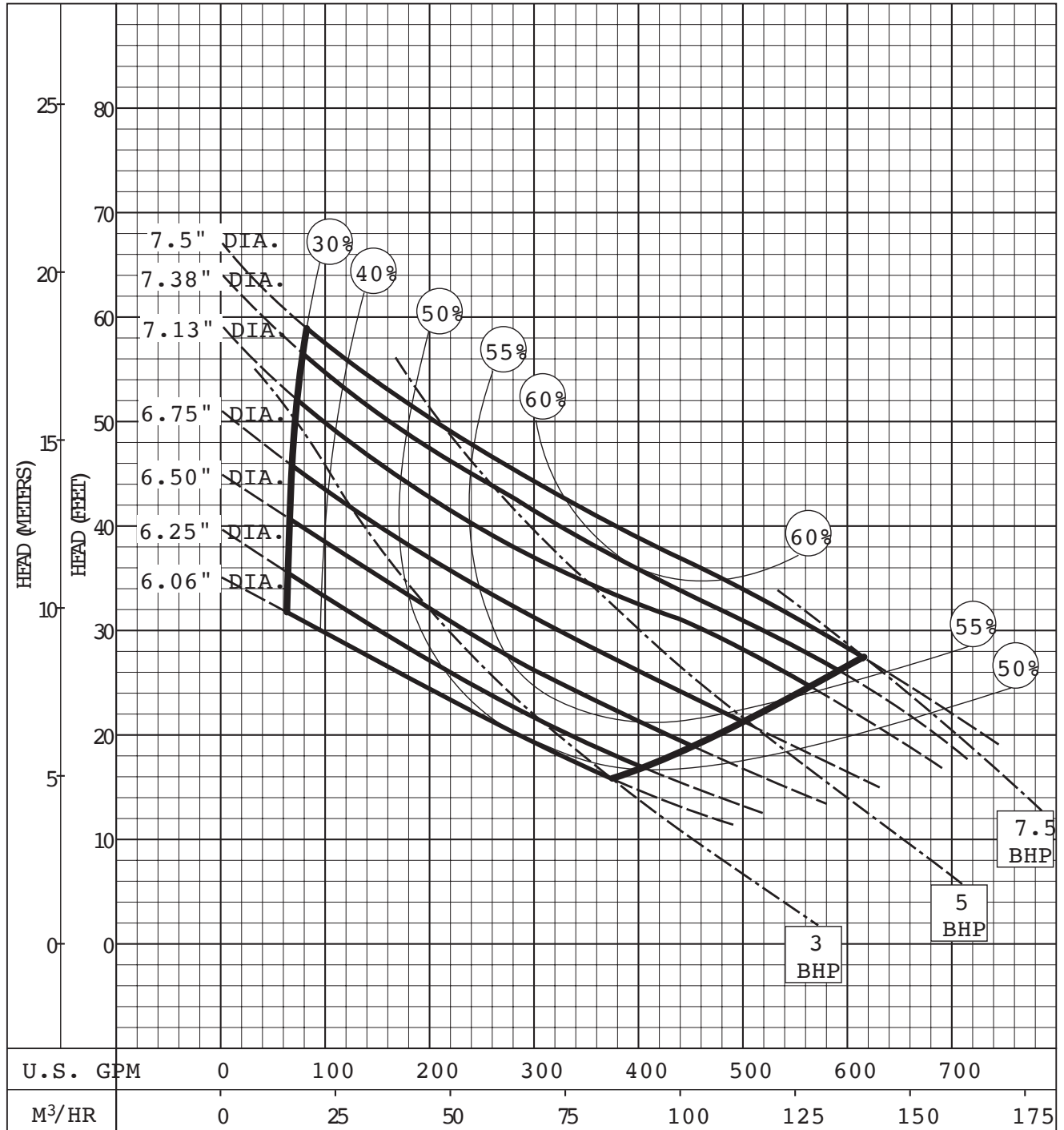

The curves reflect maximum performance characteristics without exceeding full load (Nameplate) horsepower. All pumps have a service factor of 1.2. Operation is recommended in the bounded area with operational point within the curve limit. Performance curves are based on actual tests with clear water at 70° F. and 1280 feet site elevation.

Conditions of Service:

# Performance Curve – S4SD/SB4SD

RPM: **1150** DISCHARGE: **4"** SOLIDS: **3"**

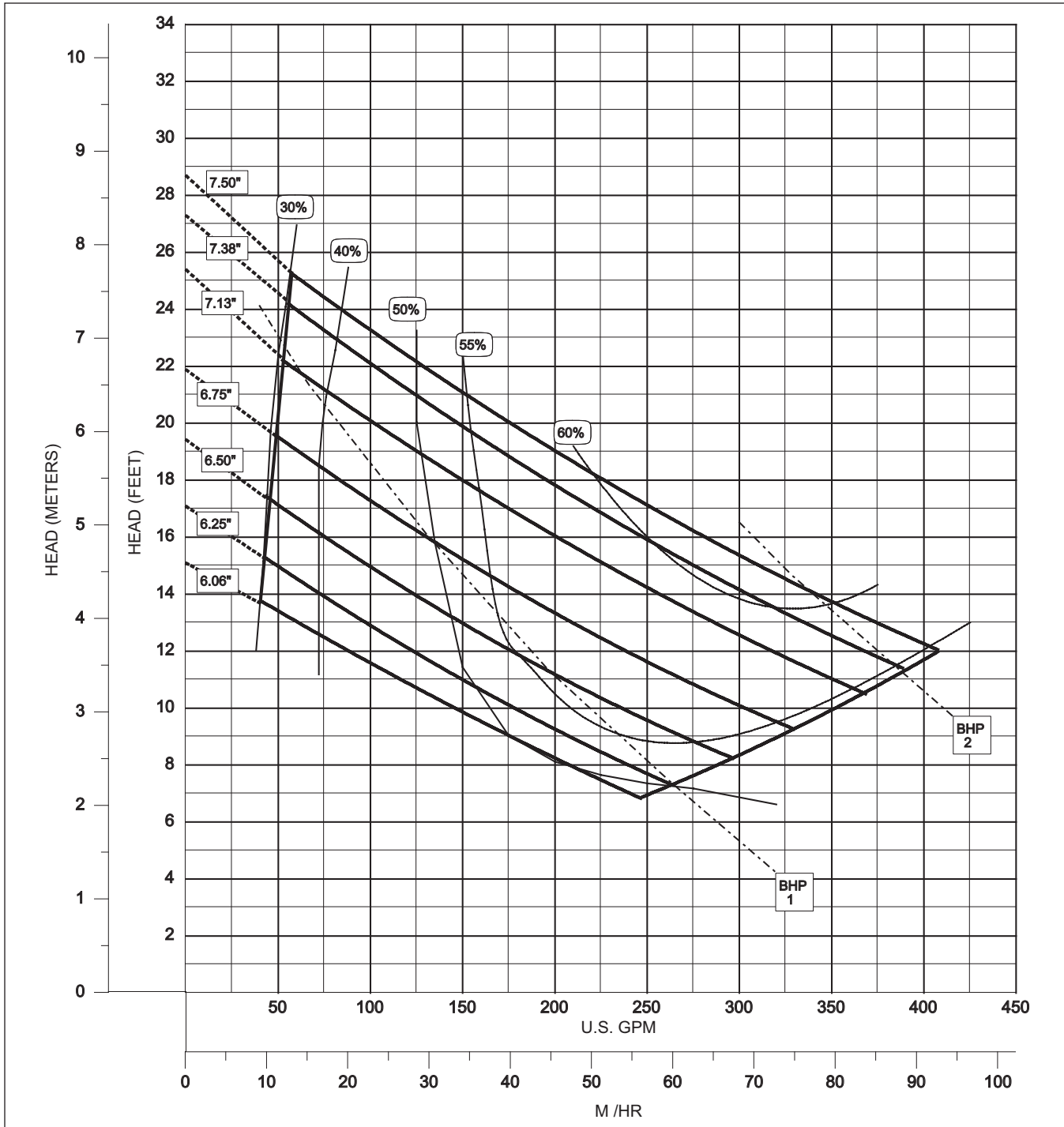

The curves reflect maximum performance characteristics without exceeding full load (Nameplate) horsepower. All pumps have a service factor of 1.2. Operation is recommended in the bounded area with operational point within the curve limit. Performance curves are based on actual tests with clear water at 70° F. and 1280 feet site elevation.

Conditions of Service:



HYDROMATIC®

GPM: \_\_\_\_\_ TDH: \_\_\_\_\_

May © 2016 Pentair plc

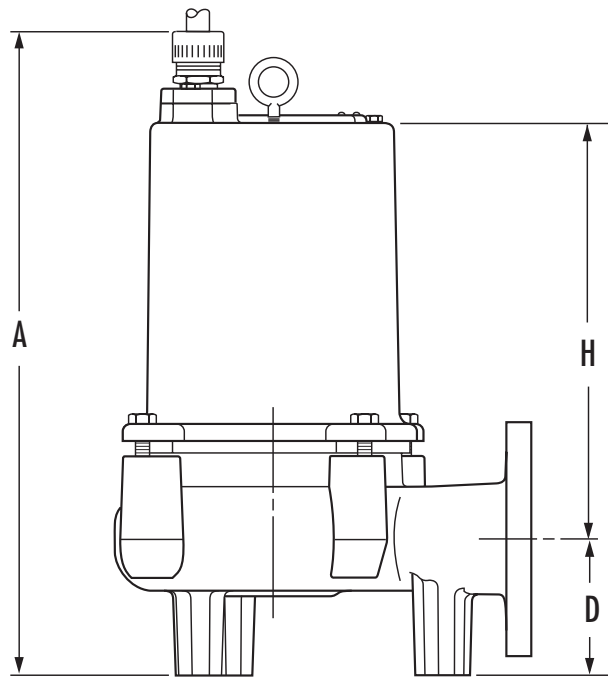
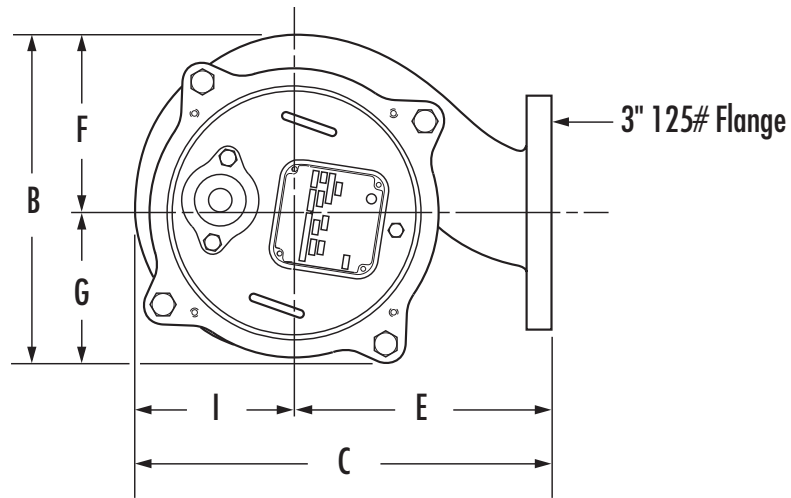

	<b>A</b>	<b>B</b>	<b>C</b>	<b>D</b>	<b>E</b>	<b>F</b>	<b>G</b>	<b>H</b>	<b>I</b>
<b>S3S</b>	20-5/8	10-1/2	13-3/8	4-3/8	8-1/4	5-5/8	4-7/8	13-3/8	5-1/8

ALL DIMENSIONS IN INCHES  
 NOTE: CASTING DIMENSIONS MAY VARY ± 1/8"

# Dimensional Data – SB3S

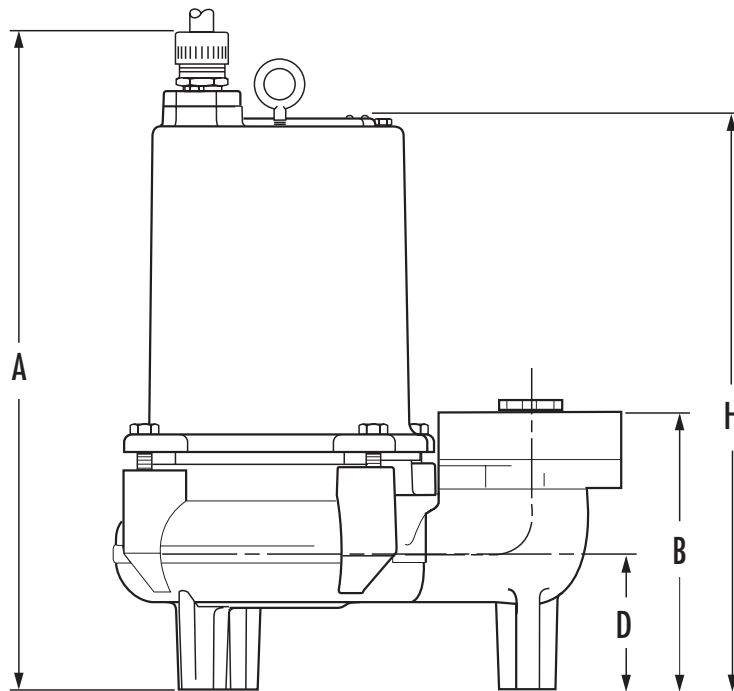
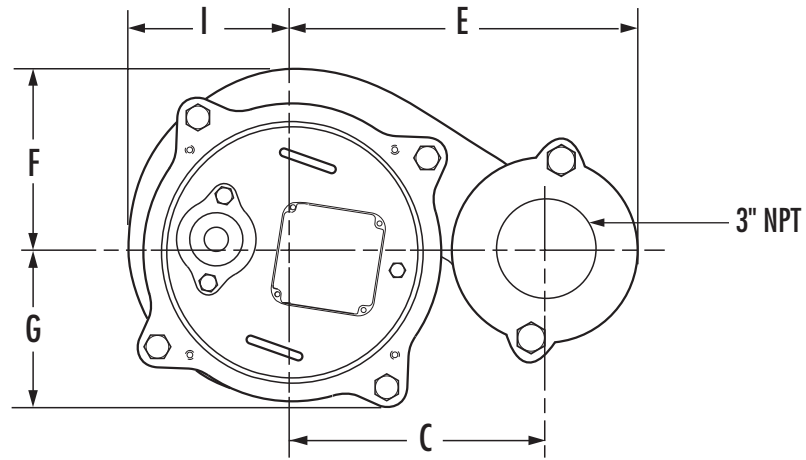

	<b>A</b>	<b>B</b>	<b>C</b>	<b>D</b>	<b>E</b>	<b>F</b>	<b>G</b>	<b>H</b>	<b>I</b>
<b>SB3S</b>	20-5/8	8-3/4	7-7/8	4-3/8	10-11/16	5-13/16	4-13/16	18-1/16	5-7/32

ALL DIMENSIONS IN INCHES  
NOTE: CASTING DIMENSIONS MAY VARY ± 1/8"

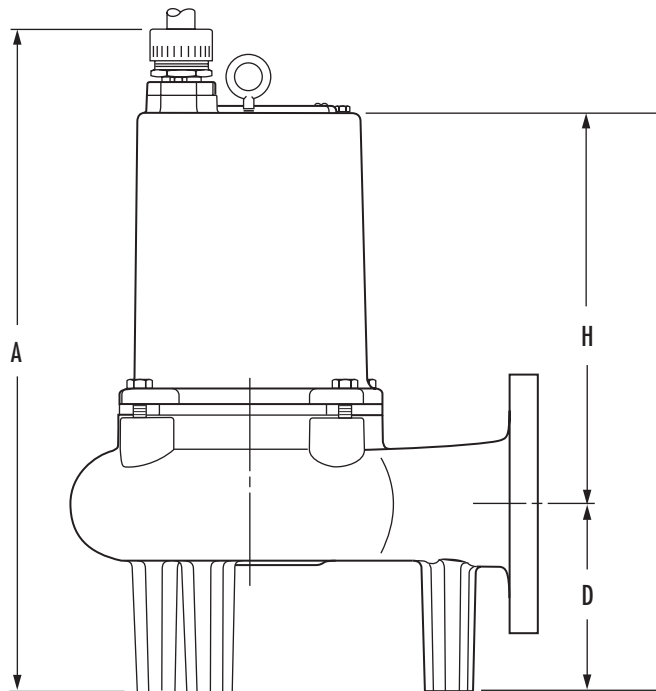
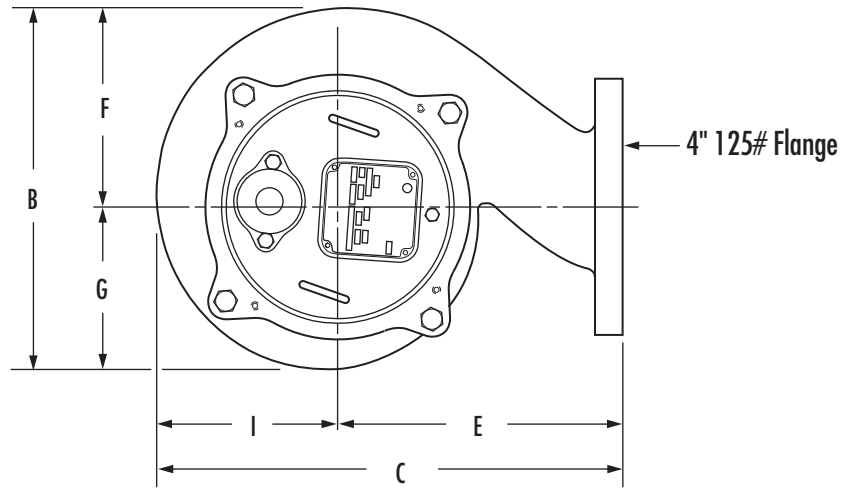

	A	B	C	D	E	F	G	H	I
<b>S4S</b>	23-1/8	12-3/4	16-3/8	6-1/2	10	7	5-3/4	13-5/8	6-3/8

ALL DIMENSIONS IN INCHES  
 NOTE: CASTING DIMENSIONS MAY VARY ± 1/8"

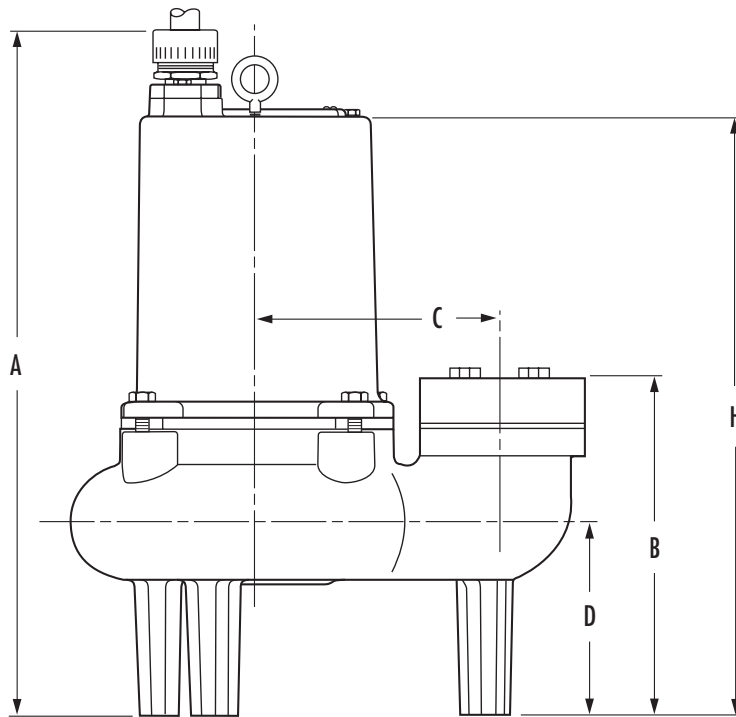
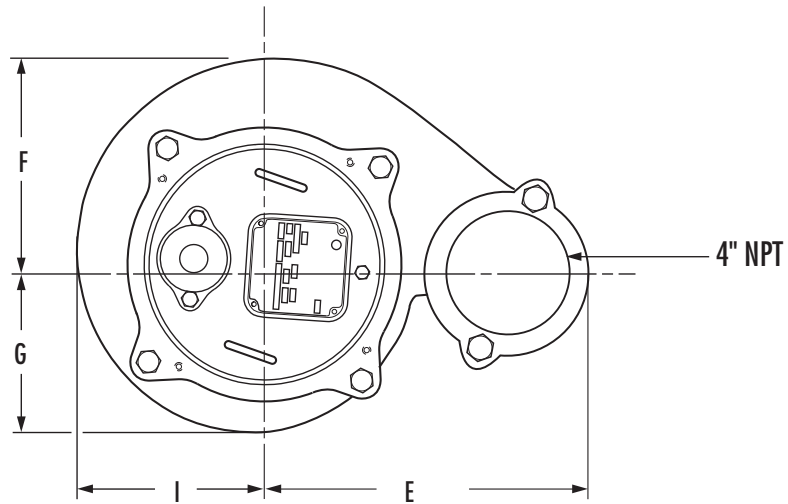

	<b>A</b>	<b>B</b>	<b>C</b>	<b>D</b>	<b>E</b>	<b>F</b>	<b>G</b>	<b>H</b>	<b>I</b>
<b>SB4S</b>	23-1/8	11-3/8	8-5/16	6-1/2	11-1/8	7-1/16	5-13/16	20-3/16	6-1/2

ALL DIMENSIONS IN INCHES  
NOTE: CASTING DIMENSIONS MAY VARY ± 1/8"



# Dimensional Data – S3SD

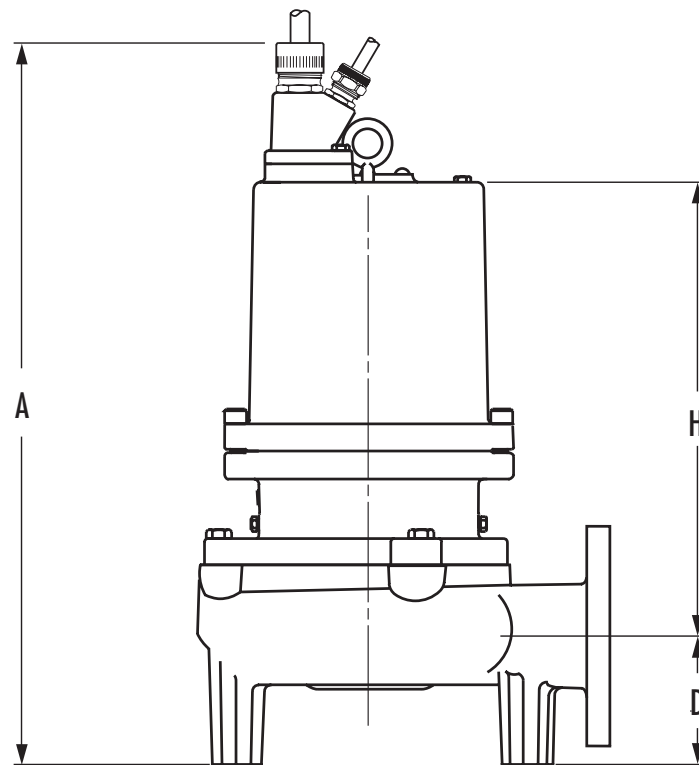
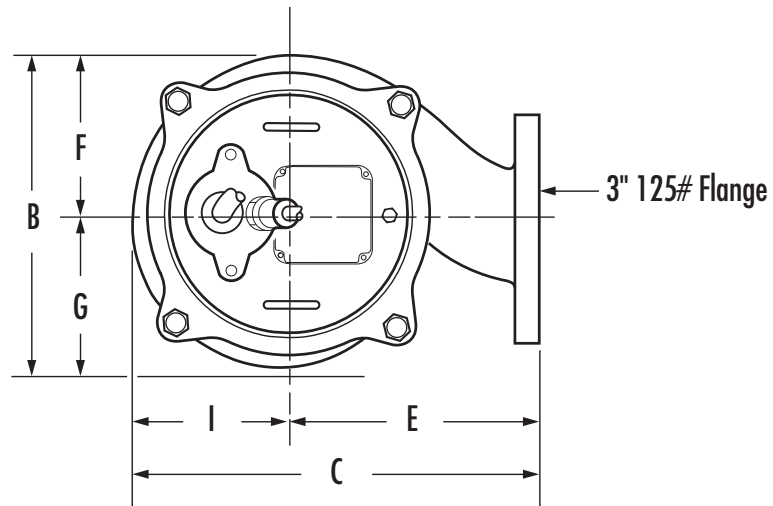

	A	B	C	D	E	F	G	H	I
<b>S3SD</b>	24-5/8	10-1/2	13-3/8	4-3/8	8-1/4	5-5/8	4-7/8	15-3/4	5-1/8

ALL DIMENSIONS IN INCHES  
NOTE: CASTING DIMENSIONS MAY VARY  $\pm 1/8"$

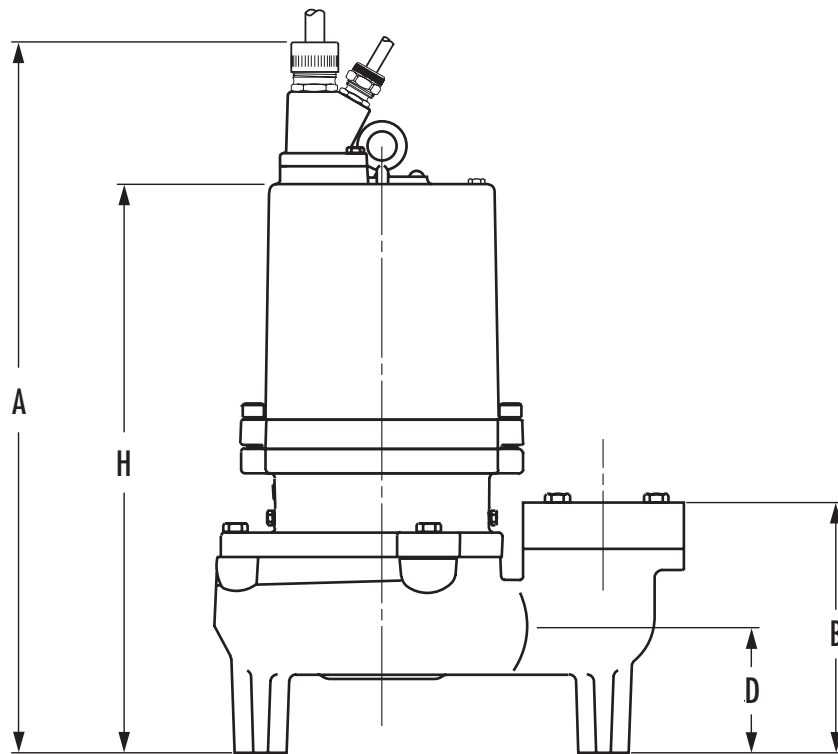
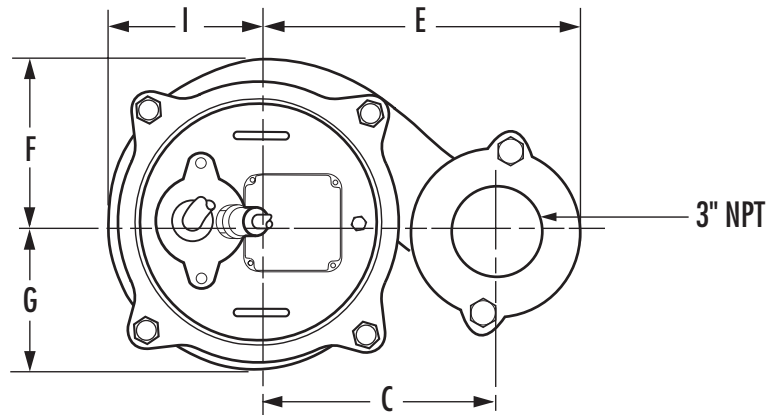

	<b>A</b>	<b>B</b>	<b>C</b>	<b>D</b>	<b>E</b>	<b>F</b>	<b>G</b>	<b>H</b>	<b>I</b>
<b>SB3SD</b>	26	8-1/2	7-3/4	4-3/8	10-5/8	5-13/16	4-13/16	20-1/2	5-7/32

ALL DIMENSIONS IN INCHES  
NOTE: CASTING DIMENSIONS MAY VARY ± 1/8"

# Dimensional Data – S4SD

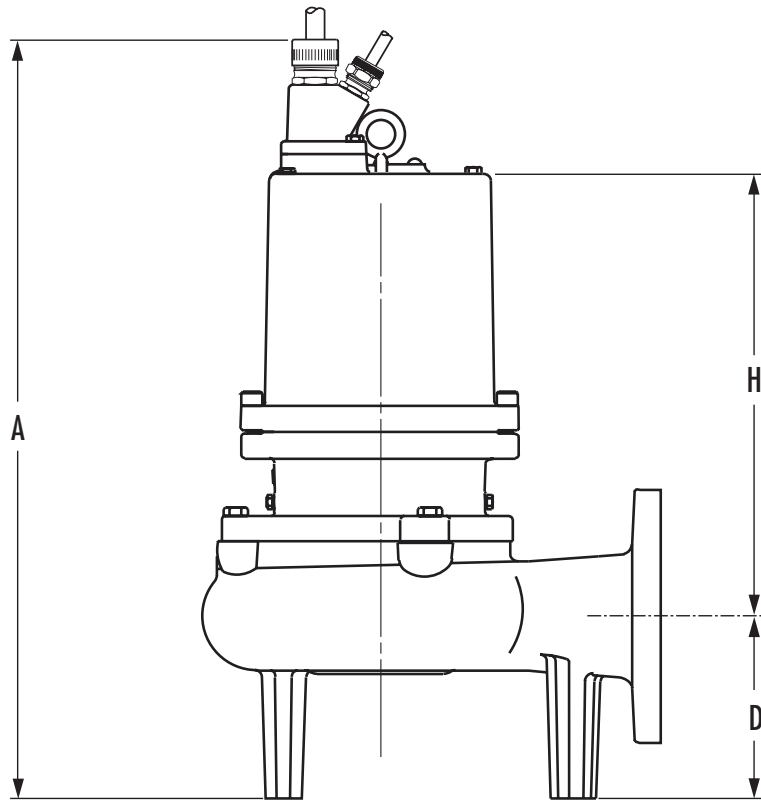
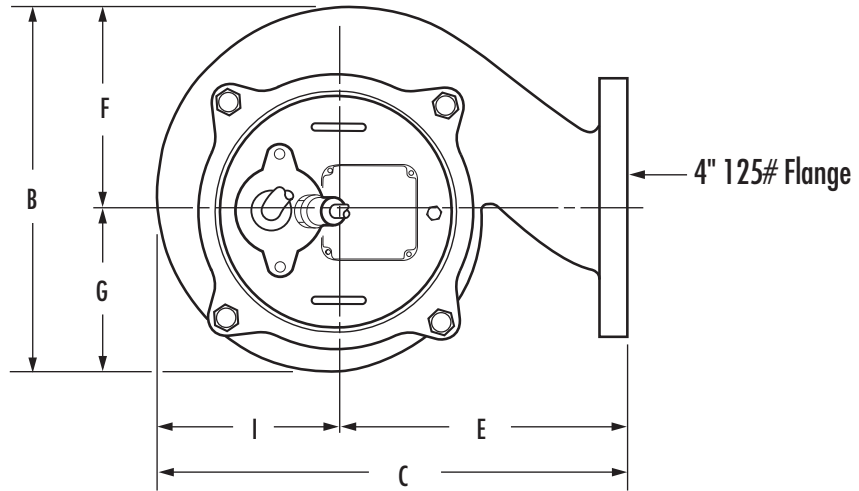

	A	B	C	D	E	F	G	H	I
<b>S4SD</b>	27	12-3/4	16-3/8	6-1/2	10	7	5-3/4	15-3/4	6-3/8

ALL DIMENSIONS IN INCHES  
NOTE: CASTING DIMENSIONS MAY VARY ± 1/8"

# Dimensional Data – SB4SD

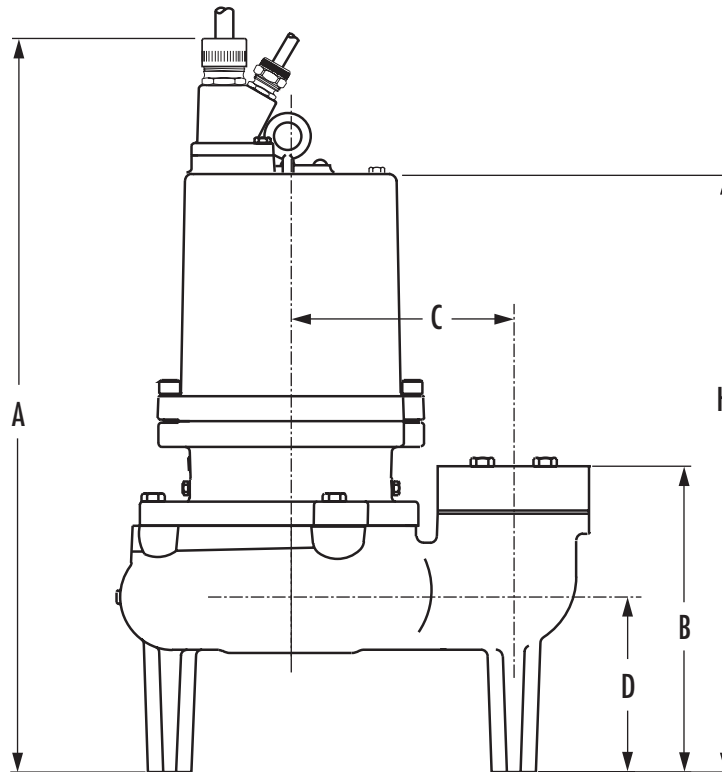
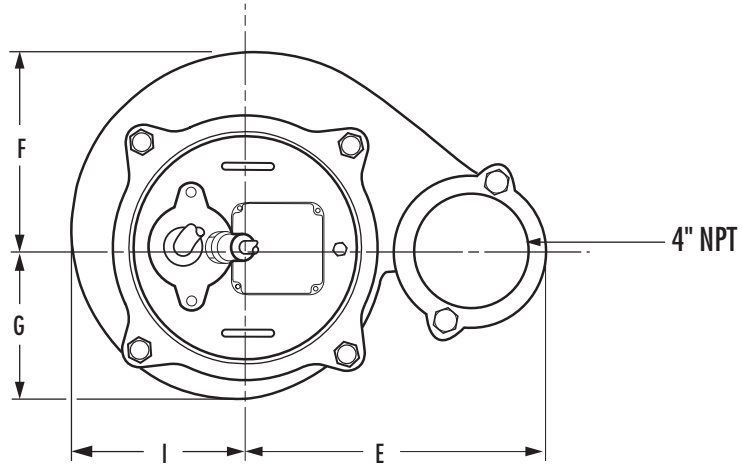

	<b>A</b>	<b>B</b>	<b>C</b>	<b>D</b>	<b>E</b>	<b>F</b>	<b>G</b>	<b>H</b>	<b>I</b>
<b>SB4SD</b>	29	11-1/4	8-9/32	6-5/8	11-1/8	7-1/8	5-15/16	23-1/2	6-1/2

ALL DIMENSIONS IN INCHES  
NOTE: CASTING DIMENSIONS MAY VARY ± 1/8"

# Electrical Data – S3S/SB3S & S4S/SB4S

## MODEL: S3S/SB3S & S4S/SB4S — Sewage Pump

R.P.M.	1750
MOTOR TYPE	ENCLOSED, OIL COOLED INDUCTION, VFD SUITABLE
MOTOR DESIGN NEMA TYPE	B (3 $\phi$ ) L (1 $\phi$ )
GENERAL INSULATION CLASS	F
STATOR WINDING CLASS	F
MAXIMUM STATOR TEMPERATURE	311°F
MOTOR PROTECTION	BI-METALLIC, TEMPERATURE SENSITIVE DISC, SIZED TO OPEN AT 120°C AND AUTOMATICALLY RESET @ 30–35°C DIFFERENTIAL, ONE IN SINGLE PHASE, TWO IN THREE PHASE
VOLTAGE TOLERANCE	±10%

HP	VOLTAGE	PHASE	NEC CODE	SF	FULL LOAD AMPS	FULL LOAD kW	LOAD RTR. AMPS	START KVA	FULL LOAD KVA	MTR. EFF. 100% FL	MTR. EFF. 75% FL	MTR. EFF. 50% FL	PWR. FACT. 100% FL	PWR. FACT. 75% FL	PWR. FACT. 50% FL
2.0	230	1	J	1.2	12.8	2.6	66	15.2	2.9	.76	.75	.71	.89	.85	.77
2.0	208	3	K	1.2	7.8	2.2	49	17.6	2.4	.69	.65	.56	.76	.69	.59
	230		K		6.8	2.2	44	17.5	2.3						
	460		K		3.4	2.2	22	17.5	2.3						
	575		K		2.7	2.2	18	17.9	2.3						
3.0	230	1	J	1.2	17.1	3.5	100	23	3.9	.73	.69	.62	.85	.79	.70
3.0	208	3	G	1.2	10.9	3.5	49	17.6	3.8	.72	.70	.64	.88	.85	.79
	230		G		9.5	3.7	44	17.5	3.8						
	460		G		4.8	3.7	22	17.5	3.8						
	575		G		3.8	3.6	18	17.9	3.8						
5.0	230	1	E	1.2	29.5	5.4	108	24.8	6.8	.69	.67	.59	.86	.82	.72
5.0	208	3	J	1.2	17.6	5.5	106	38.1	6.3	.75	.73	.68	.76	.68	.58
	230		J		15.3	5.4	96	38.2	6.1						
	460		J		7.6	5.4	48	38.2	6.0						
	575		J		6.1	5.4	39	38.8	6.1						
7.5	208	3	H	1.2	29.0	10.1	135	48.6	10.4	.76	.74	.69	.75	.67	.54
	230		H		25.2	8.3	122	48.5	10.0						
	460		H		12.6	8.3	61	48.5	10.0						
	575		H		10.1	6.9	49	48.7	10.0						

# Electrical Data – S3SD/SB3SD & S4SD/SB4SD

## MODEL: S3SD/SB3SD & S4SD/SB4SD — Sewage Pump

R.P.M.	1750			
MOTOR TYPE	ENCLOSED, OIL COOLED INDUCTION, VFD SUITABLE			
MOTOR DESIGN NEMA TYPE	B (3Ø) L (1Ø)			
GENERAL INSULATION CLASS	F			
STATOR WINDING CLASS	F			
MAXIMUM STATOR TEMPERATURE	311°F			
MOTOR PROTECTION	BI-METALLIC, TEMPERATURE SENSITIVE DISC, SIZED TO OPEN AT 120°C AND AUTOMATICALLY RESET @ 30–35°C DIFFERENTIAL, ONE IN SINGLE PHASE, TWO IN THREE PHASE			
ELECTRICAL RATINGS	HEAT SENSOR	24VDC 5AMPS	115VAC 5AMPS	230VAC 5AMPS
	SEAL FAIL	300VAC 5mA		
VOLTAGE TOLERANCE	±10%			

HP	VOLTAGE	PHASE	NEC CODE	SF	FULL LOAD AMPS	FULL LOAD KW	LOAD. RTR. AMPS	START KVA	FULL LOAD KVA	MTR. EFF. 100% FL	MTR. EFF. 75% FL	MTR. EFF. 50% FL	PWR. FACT. 100% FL	PWR. FACT. 75% FL	PWR. FACT. 50% FL
2.0	230	3	J	1.2	12.8	2.6	66	15.2	2.9	.76	.75	.71	.89	.85	.77
	208		K		7.8	2.2	49	17.6	2.4	.69	.65	.56	.76	.69	.59
	230		K		6.8	2.2	44	17.5	2.3						
	460		K		3.4	2.2	22	17.5	2.3						
575	K	2.7	2.2	18	17.9	2.3									
3.0	230	3	J	1.2	17.1	3.5	100	23	3.9	.73	.69	.62	.85	.79	.70
	208		G		10.9	3.5	49	17.6	3.8	.72	.70	.64	.88	.85	.79
	230		G		9.5	3.7	44	17.5	3.8						
	460		G		4.8	3.7	22	17.5	3.8						
575	G	3.8	3.6	18	17.9	3.8									
5.0	230	3	E	1.2	29.5	5.4	108	24.8	6.8	.69	.67	.59	.86	.82	.72
	208		J		17.6	5.5	106	38.1	6.3	.75	.73	.68	.76	.68	.58
	230		J		15.3	5.4	96	38.2	6.1						
	460		J		7.6	5.4	48	38.2	6.0						
575	J	6.1	5.4	39	38.8	6.1									
7.5	208	3	H	1.2	29.0	10.1	135	48.6	10.4	.76	.74	.69	.75	.67	.54
	230		H		25.2	8.3	122	48.5	10.0						
	460		H		12.6	8.3	61	48.5	10.0						
	575		H		10.1	6.9	49	48.7	10.0						

# Electrical Data – S3SD/SB3SD & S4SD/SB4SD

## MODEL: S3SD/SB3SD & S4SD/SB4SD — Sewage Pump

R.P.M.	1150			
MOTOR TYPE	ENCLOSED, OIL COOLED INDUCTION, VFD SUITABLE			
MOTOR DESIGN NEMA TYPE	B (3Ø) L (1Ø)			
GENERAL INSULATION CLASS	F			
STATOR WINDING CLASS	F			
MAXIMUM STATOR TEMPERATURE	311°F			
MOTOR PROTECTION	BI-METALLIC, TEMPERATURE SENSITIVE DISC, SIZED TO OPEN AT 120°C AND AUTOMATICALLY RESET @ 30–35°C DIFFERENTIAL, ONE IN SINGLE PHASE, TWO IN THREE PHASE			
ELECTRICAL RATINGS	HEAT SENSOR	24VDC 5AMPS	115VAC 5AMPS	230VAC 5AMPS
	SEAL FAIL	300VAC 5mA		
VOLTAGE TOLERANCE	±10%			

HP	VOLTAGE	PHASE	NEC CODE	SF	FULL LOAD AMPS	SF AMPS	LOCKED-ROTOR AMPS	FULL LOAD KW	START KVA	FULL LOAD KVA	MTR. EFF. @ SF	MTR. EFF. 100% FL	MTR. EFF. 75% FL	MTR. EFF. 50% FL	PWR. FACT. @ SF	PWR. FACT. 100% FL	PWR. FACT. 75% FL	PWR. FACT. 50% FL	
1.0	208	1	N	1.2	9.4	10.2	54	1.0	11.2	1.9	.59	.57	.52	.43	.75	.70	.65	.54	
	230		L		8.2	8.9	42	1.3	9.7										
1.0	208	3	L	1.2	4.3	5.0	27	1.1	9.7	1.5	.71	.70	.68	.61	.74	.71	.64	.54	
	230		K		3.8	4.3	23		9.2										
	460		K		1.9	2.2	11		8.8										
	575		H		1.5	1.7	7		7.0										
2	208	1	K	1.2	18.6	20.6	82	2.6	17.1	3.9	.60	.59	.55	.47	.73	.68	.60	.50	
	230		K		17	17.9	71		16.3										
2	208	3	J	1.2	8.4	9.6	43	2.4	15.5	2.9	.74	.74	.73	.67	.73	.70	.62	.52	
	230		K		7.3	8.3	42		2.2										16.7
	460		K		3.6	4.2	21		2.2										16.7
	575		K		2.9	3.3	17		2.2										16.9

**THIS PAGE INTENTIONALLY LEFT BLANK**



## MODEL: S3S/SB3S — Standard Single Seal Sewage Ejector Pumps

### Physical Data:

DISCHARGE SIZE	3"
IMPELLER TYPE	BALANCED, SEMI OPEN, 2 VANE
CABLE LENGTH	35' STANDARD

### Liquid Handling:

SOLIDS SIZE	2-1/2"
MAXIMUM LIQUID	140°F
ACCEPTABLE LIQUID	6 - 9
SPECIFIC GRAVITY	0.9 - 1.1
VISCOSITY	28 - 35 SSU

### Temperature:

MAXIMUM STATOR	311°F
OIL FLASH POINT	390°F
HEAT SENSOR	Open: 257°F MAX./239°F MIN. Closed: 194°F MAX./119°F MIN.

### Technical Data:

POWER CORD TYPE	SOOW, W	
MATERIALS OF CONSTRUCTION	MOTOR HOUSING	CAST IRON    ASTM    A-48    CLASS 30
	CASING	CAST IRON    ASTM    A-48    CLASS 30
	IMPELLER	DUCTILE IRON    ASTM    536
	MOTOR SHAFT	400 STAINLESS STEEL
	HARDWARE	300 SERIES STAINLESS STEEL
	"O" RINGS	NITRILE
MECHANICAL SEALS	Standard: CARBON/CERAMIC/NITRILE, TYPE 21	
UPPER BEARING	(RADIAL) SINGLE ROW — BALL	
LOWER BEARING	(THRUST) SINGLE ROW — BALL	

**MODEL: S4S/SB4S — Standard Single Seal Sewage Ejector Pumps****Physical Data:**

DISCHARGE SIZE	4"
IMPELLER TYPE	BALANCED, SEMI OPEN, 2 VANE
CABLE LENGTH	35' STANDARD 50' OPTIONAL

**Liquid Handling:**

SOLIDS SIZE	3"
MAXIMUM LIQUID	140°F
ACCEPTABLE PH RANGE	6 - 9
SPECIFIC GRAVITY	0.9 - 1.1
VISCOSITY	28 - 35 SSU

**Temperature:**

MAXIMUM STATOR	311°F
OIL FLASH POINT	390°F
HEAT SENSOR	Open: 257°F MAX./239°F MIN. Closed: 194°F MAX./119°F MIN.

**Technical Data:**

POWER CORD TYPE	SOOW, W	
MATERIALS OF CONSTRUCTION	MOTOR HOUSING	CAST IRON ASTM A-48 CLASS 30
	CASING	CAST IRON ASTM A-48 CLASS 30
	IMPELLER	DUCTILE IRON ASTM 536
	MOTOR SHAFT	400 STAINLESS STEEL
	HARDWARE	300 SERIES STAINLESS STEEL
	"O" RINGS	NITRILE
MECHANICAL SEALS	Standard: CARBON/CERAMIC/NITRILE, TYPE 21	
UPPER BEARING (RADIAL)	SINGLE ROW — BALL	
LOWER BEARING	(THRUST) SINGLE ROW — BALL	

## MODEL: S3SD/SB3SD — Standard Dual Seal Sewage Ejector Pumps

### Physical Data:

DISCHARGE SIZE	3"
IMPELLER TYPE	BALANCED, SEMI OPEN, 2 VANE
CABLE LENGTH	35' STANDARD 50' OPTIONAL

### Liquid Handling:

SOLIDS SIZE	2-1/2"
MAXIMUM LIQUID	140°F
ACCEPTABLE PH RANGE	6 - 9
SPECIFIC GRAVITY	0.9 - 1.1
VISCOSITY	28 - 35 SSU

### Temperature:

MAXIMUM STATOR	311°F
OIL FLASH POINT	390°F
HEAT SENSOR	Open: 257°F MAX./239°F MIN. Closed: 194°F MAX./119°F MIN.

### Technical Data:

POWER CORD TYPE	SOOW, W				
MATERIALS OF CONSTRUCTION	MOTOR HOUSING	CAST IRON	ASTM	A-48	CLASS 30
	CASING	CAST IRON	ASTM	A-48	CLASS 30
	IMPELLER	DUCTILE IRON	ASTM	536	
	MOTOR SHAFT	400 STAINLESS STEEL			
	HARDWARE	300 SERIES STAINLESS STEEL			
	"O" RINGS	NITRILE			
MECHANICAL SEALS	Standard:	CARBON/CERAMIC/NITRILE, TYPE 21			
UPPER BEARING(RADIAL)	SINGLE ROW — BALL				
LOWER BEARING	(THRUST) SINGLE ROW — BALL				

**MODEL: S4SD/SB4SD — Standard Dual Seal Sewage Ejector Pumps****Physical Data:**

DISCHARGE SIZE	4"
IMPELLER TYPE	BALANCED, SEMI OPEN, 2 VANE
CABLE LENGTH	35' STANDARD

**Liquid Handling:**

SOLIDS SIZE	3"
MAXIMUM LIQUID	140°F
ACCEPTABLE PH RANGE	6 - 9
SPECIFIC GRAVITY	0.9 - 1.1
VISCOSITY	28 - 35 SSU

**Temperature:**

MAXIMUM STATOR	311°F
OIL FLASH POINT	390°F
HEAT SENSOR	Open: 257°F MAX./239°F MIN. Closed: 194°F MAX./119°F MIN.

**Technical Data:**

POWER CORD TYPE	SOOW, W	
MATERIALS OF CONSTRUCTION	MOTOR HOUSING	CAST IRON ASTM A-48 CLASS 30
	CASING	CAST IRON ASTM A-48 CLASS 30
	IMPELLER	DUCTILE IRON ASTM 536
	MOTOR SHAFT	400 STAINLESS STEEL
	HARDWARE	300 SERIES STAINLESS STEEL
	"O" RINGS	NITRILE
MECHANICAL SEALS	Standard: CARBON/CERAMIC/NITRILE, TYPE 21	
UPPER BEARING	(RADIAL) SINGLE ROW — BALL	
LOWER BEARING	(THRUST) SINGLE ROW — BALL	

# Specifications – Ejector

## 3" & 4" SUBMERSIBLE SEWAGE PUMPS

### GENERAL

Furnish all labor, materials, equipment and incidentals required to provide \_\_\_\_\_ (qty.) solids handling submersible centrifugal sewage pumps(s) as specified herein.

### OPERATING CONDITIONS

Each pump shall be rated \_\_\_\_\_ HP, \_\_\_\_\_ volts, \_\_\_\_\_ phase, \_\_\_\_\_ hertz, and \_\_\_\_\_ RPM. The unit shall produce \_\_\_\_\_ U.S. GPM at \_\_\_\_\_ feet TDH. The S3S shall be capable of handling a 2-1/2" spherical solid and the S4S a 3" spherical solid. The pump shall be non-overloading throughout the entire range of operation without employing service factor. The pump shall reserve a minimum service factor of 1.20. The performance curve submitted for approval shall state in addition to head and capacity performance, the pump efficiency and solid handling capability.

### CONSTRUCTION

Each pump shall be of the sealed submersible type, Models S3S, S4S, SB3S, SB4S, S3SD, S4SD, SB3SD, and SB4SD as manufactured by Hydromatic Pump. The pump volute, motor and seal housing shall be high quality gray cast iron, ASTM A-48, Class 30. The pump discharge shall be fitted with a 3" standard ASA 125 lb. flange, faced and drilled for the S3S models, and a 4" standard ASA 125 lb. flange, faced and drilled for the S4S models. All external mating parts shall be machined and Nitrile O-ring sealed on a beveled edge. Gaskets shall not be acceptable. All fasteners exposed to the pumped liquids shall be 300 series stainless steel.

### ELECTRICAL POWER CORD

Electrical power cord shall be SOOW or W, water resistant 600V, 90°C, UL and CSA approved and applied dependent on amp draw for size.

The pump shall be double protected with compression fitting and an epoxy potted area at the power cord entry to the pump.

The power cable entry into the cord cap assembly shall first be made with a compression fitting. Each individual lead shall be stripped down to the bare wire, at staggered intervals, and each strand shall be individually separated. This area of the cord cap shall then be filled with an epoxy compound potting which will prevent water contamination to gain entry even in the event of wicking or capillary attraction.

The power cord assembly shall then be connected to the motor leads with insulated butt connectors rather than a terminal board that allows for possible leaks.

The cord cap assembly where bolted to the motor housing shall be sealed with a Nitrile O-ring on a beveled edge to assure proper sealing.

### MOTOR

The stator, rotor and bearings shall be mounted in a sealed submersible type housing. The stator windings shall have Class F insulation (155°C or 311°F) and dielectric oil-filled motor, NEMA B design. Single-phase motors shall have thermal type overload protection with automatic reset and be capacitor start with capacitor located in the control panel. Three phase motors shall use magnetic starters with overload relays located in the control panel for further protection. Because air-filled motors do not dissipate heat as efficiently as oil-filled motors, air-filled designs shall not be acceptable.

Stators shall be securely held in place with threaded fasteners so they may be easily removed in the field. No special tools shall be required for pump and motor disassembly.

**BEARINGS AND SHAFT**

An upper radial bearing and lower thrust bearing shall be required. Both the upper radial bearing and the lower thrust bearing shall be heavy-duty single row ball bearings that are permanently lubricated by the dielectric oil that fills the motor housing. Double row, sealed grease packed bearings shall not be acceptable. Bearings that require lubrication according to a prescribed schedule shall not be acceptable.

The shaft shall be machined from a solid 400 stainless steel and be a design that is of larger diameter with minimum overhand to reduce shaft deflection and prolong bearing life.

**SEALS**

The S3S, S4S, SB3S, and SB4S shall have a mechanical single seal, Type 21. The S3SD, S4SD, SB3SD, and SB4SD shall have a mechanical dual seal, Type 21. The seal shall be used with the rotating seal face being carbon and the stationary seal face to be ceramic. The seal shall be replaceable without disassembly of the seal plate and without the use of special tools. Pump-out vanes shall be present on the backside of the impeller to keep contaminants out of the seal area. Units that require the use of tungsten-carbide seals or foreign manufactured seals shall not be acceptable.

**IMPELLER**

Impeller shall be of the two-vane, semi-enclosed design and have pump-out vanes on the backside of the impeller to prevent grit and other materials from collecting in the seal area. Single vane design impellers that cannot be easily trimmed and that do not maintain balance with wear, causing shaft defections and reducing seal and bearing life, are not acceptable. Impeller shall not require coating. Because most impeller coatings do not remain beyond the very early life of the impeller, efficiency and other performance data submitted shall be based on performance with an uncoated impeller. Attempts to improve efficiency by coating impeller shall not be acceptable.

Impellers shall be dynamically balanced. The tolerance values shall be as listed below according to the International Standard Organization grade 6.3 for rotors in rigid frames.

<b>RPM</b>	<b>Tolerance</b>
1750	.02 in. – oz./lb. of impeller weight

The impeller shall be slip fit to the shaft and key driven. A 400 series stainless steel washer and impeller bolt shall be used to fasten the impeller to the shaft. Threaded shafts for attachment of the impeller shall not be acceptable.

**CASING**

The casing shall be of the end suction volute type having sufficient strength and thickness to withstand all stress and strain from service at full operating pressure and load. The casing shall be of the centerline discharge type equipped with an automatic pipe coupling arrangement for ease of installation and piping alignment. The design shall be such that the pumps will be automatically connected to the discharge piping when lowered into position with the guide rails. The casing shall be accurately machined and bored for register fits with the suction and casing covers.