

**ENGINEERING DATA**

DATED JUNE 1991

INTERCHANGEABILITY

Non-Clog pumps are designed for maximum interchangeability. All models are available in all 7 sizes, offering a model and size precisely fitted to the installation requirements over a wide range of capacities. The 7 sizes are divided into 4 "Power Frames". Within a given power frame, all parts are interchangeable except for the liquid end and supports. The chart illustrates the degree of interchangeability achieved with the standard non-clog pumps.

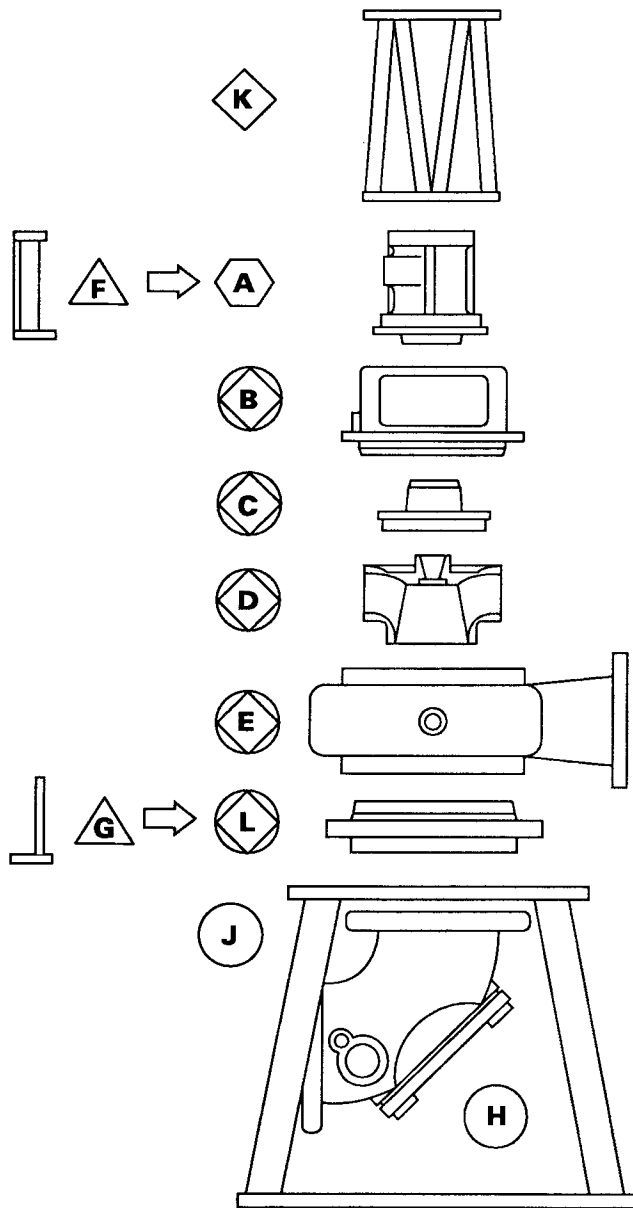

- Model 651A Only ..... ▲
- Model 653A Only ..... ◆
- Models 652A, 653A, & 654A ..... ○
- Models 651A, 652A, & 653A ..... ⬡
- Models 651A, 652A, 653A, & 654A ..... ⊗

	Qty
A - Power Frames .....	4
B - Brackets .....	6
C - Stuffing Boxes .....	3
D - Impellers .....	8
E - Casings .....	7
F - Mounting Feet (Rear) .....	5
G - Mounting Feet (Front) .....	4
H - Elbows .....	3
J - Bases .....	2
K - Motor Supports .....	3
L - Suction Covers .....	6

**POWER FRAME SELECTION**

PUMP SIZE	POWER FRAME	RPM			
		1750	1150	875	700
3x3x7	POWER FRAME	3C	3C		
4x4x7		3C	3C		
3x3x9		3C	3C		
4x4x9A		3C	3C	3C	
4x4x9B		4C	4C	4C	4C
4x4x12		5E	4C	4C	4C
4x6x15		5F	5E	5E	5E

# AURORA 650A SERIES ENGINEERING DATA

INTERCHANGEABILITY

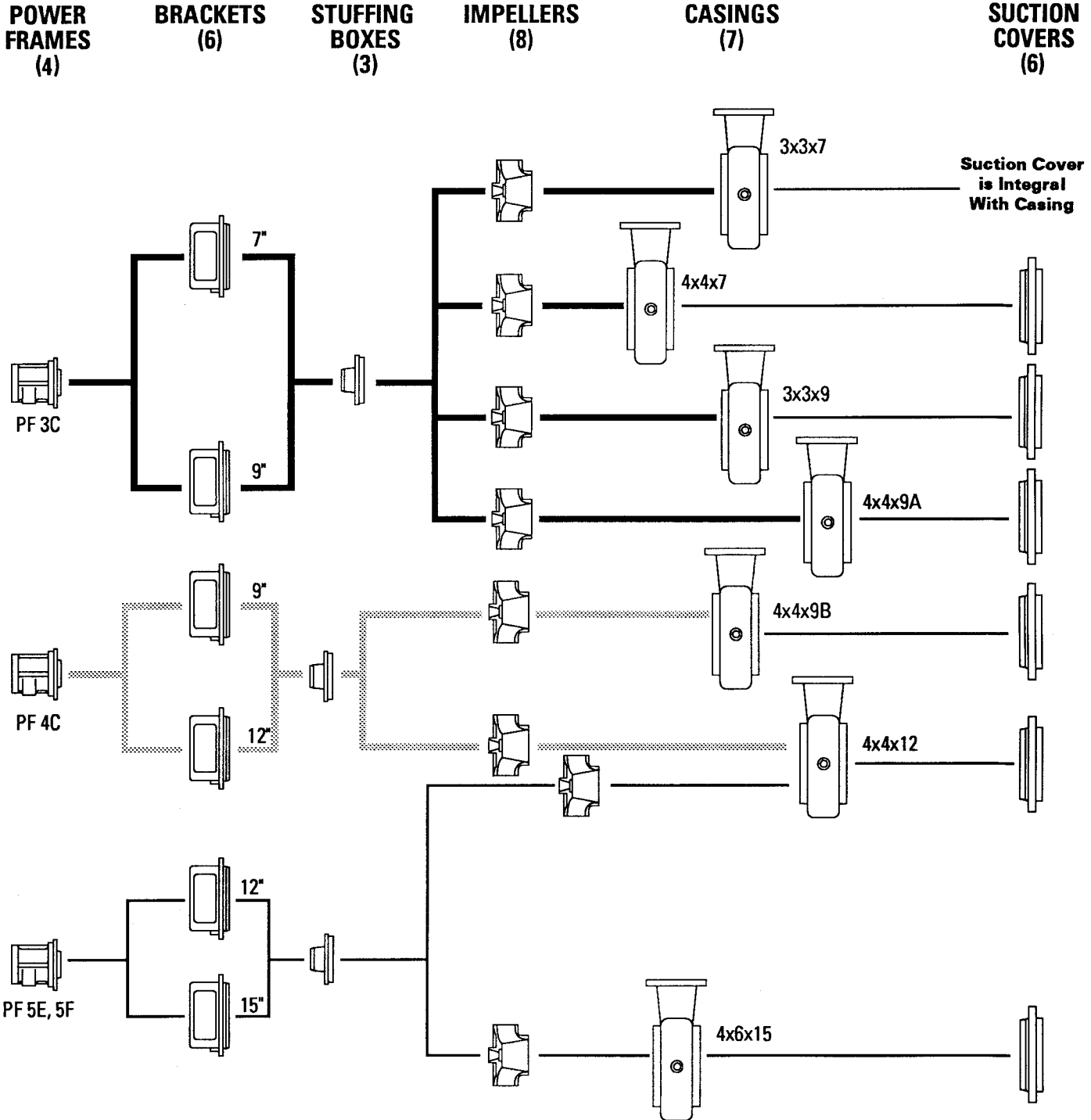

# AURORA MODEL 650 PUMP SPLIT PACKING BOX OPTION

SECTION 650 PAGE 165

DATED NOVEMBER 1988

POWER FRAMES 4 & 5 ONLY



Optional Split Packing Box  
With Leakage Accumulator  
Gland Illustrated

Split packing boxes separate vertically through the packing insert to simplify packing replacement and shaft sleeve inspection. The insert halves are dowled, register aligned and gasketed to prevent leakage. Only six bolts need be removed to expose all of the packing and lantern ring. Remove two more bolts and the remaining packing box insert half can be removed.

The completely exposed packing and sleeve area coupled with the extra large access openings in the pump adapter provides the ultimate in packing accessibility.

Five (5) die-molded, diagonally split, packing rings complete with lantern ring line the stuffing box. The general service packing consists of graphited fiber.

The stuffing box length, bore, sleeve diameters and lantern ring width conform with the recommended standard of the Mechanical Packing Association (MPA).

A tapped opening is provided for lubricating the stuffing box. Lubrication is accomplished by adding grease directly into the lantern ring cavity through a grease fitting or by connecting a by-pass line between the pump discharge and the stuffing box. Automatic grease seals as well as other flushing options are also available.

The standard 450 minimum brinell hardened stainless steel shaft sleeve extends through the entire length of the box and gland and is provided with a snap ring. This snap ring design allows the sleeve and the completely assembled packing box to be removed intact. Reassembly can be accomplished in the same manner. Assemble the complete stuffing box at the convenience of the work bench, install and adjust the packing for proper lubrication leakage (5-10 drops per minute after run-in).

# AURORA MODEL 650 PUMP LEAKAGE ACCUMULATOR

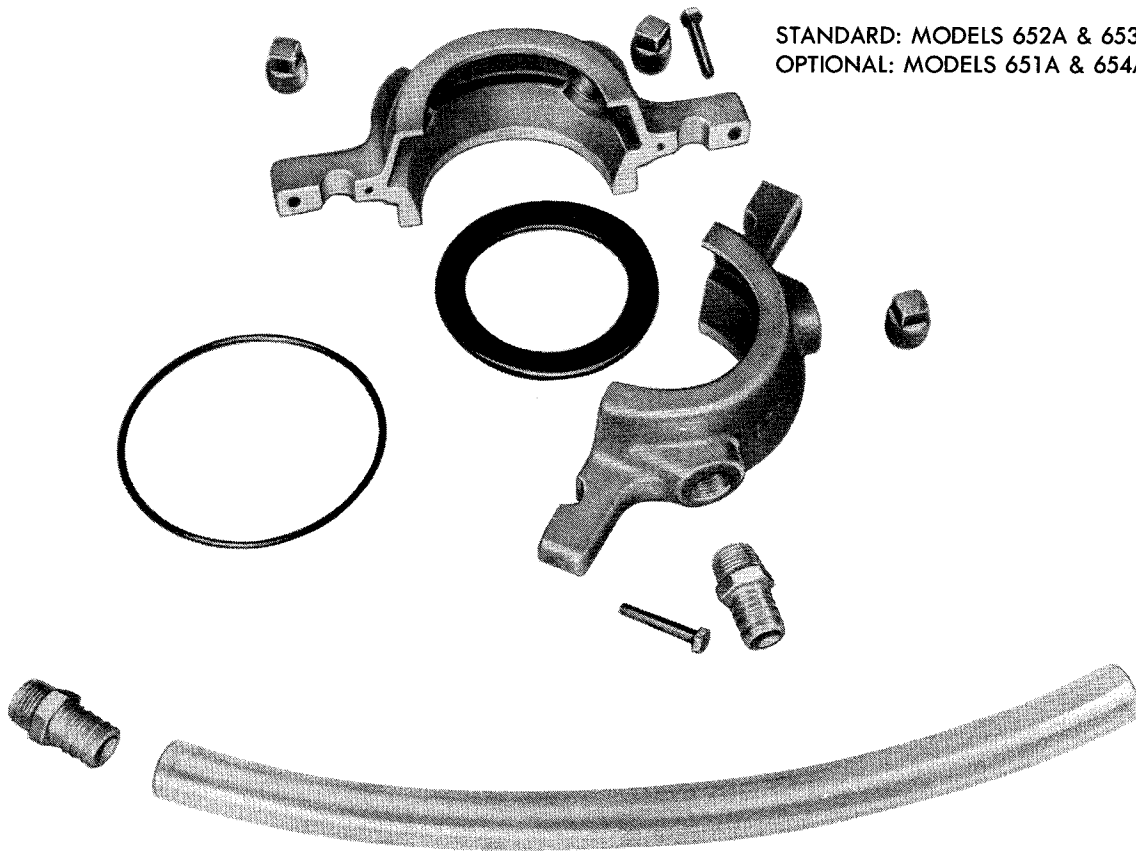

STANDARD: MODELS 652A & 653A  
OPTIONAL: MODELS 651A & 654A

The leakage accumulator gland (sprayless, dripless packing gland) is designed and constructed to prevent the collection of packing leakage in the pump bracket of a vertical or horizontally mounted pump. The leakage accumulator gland has a volute shape with two symmetrical halves. This gland encloses the water slinger preventing any spray from escaping and contaminating the area. The leakage is efficiently directed to a drain connection.

The two gland halves are doweled, bolted together, and sealed at the parting line with a soft liquid sealant. An "O" ring seal between the gland and packing box prevents any leakage in this area. One of the pipe tap ports on the side of the gland is fitted with a hose connector and a clear plastic section of hose, to both drain off and allow visual inspection of the leakage. The remaining ports have pipe plugs, but may be used for maintenance purposes to flush & drain debris from the accumulator.

# AURORA MODEL 650 PUMP DOUBLE MECHANICAL SEAL

SECTION 650 PAGE 167

DATED NOVEMBER 1988

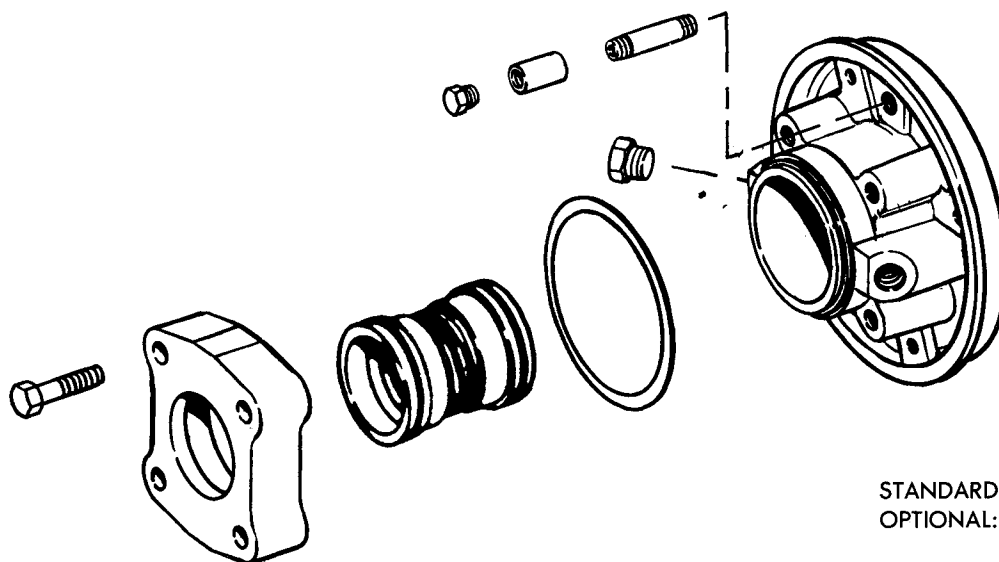

STANDARD: MODEL 654A  
OPTIONAL: MODELS 651A, 652A & 653A

Double mechanical seals are recommended for gritty or abrasive applications. Seal faces are protected by clear water under pressure, injected directly into the seal cavity. Pressure in the seal box must be fifteen (15) lbs. higher than the operating pressure at the stuffing box of the pump. This forces the inner sealing faces closed and provides both faces with a film of clear sealant. If this is not done, abrasive particles may be forced under the sealing faces hastening wear. Even when the pump is not running, a pressure differential, or at least equal pressure in the seal box, is desirable. The sealant circulation for most pumping operations may be dead ended in the stuffing box. Pressures over 30 psi or RPM of 1200 max. require constant circulation to prevent overheating.

The seal box is designed for the compressed seal length and does not require any adjustments. The seal housing is extra large to provide excellent circulation of clear sealing liquid. The housing also has two tapped openings 180° apart for the flushing connections.

The standard shaft sleeve design is provided with a snap ring which allows the sleeve and the completely assembled seal box to be removed intact. Reassembly can be accomplished in the same manner. Assemble the complete seal box at the convenience of the work bench and install.

**OPTIONS**

**SHAFTS**

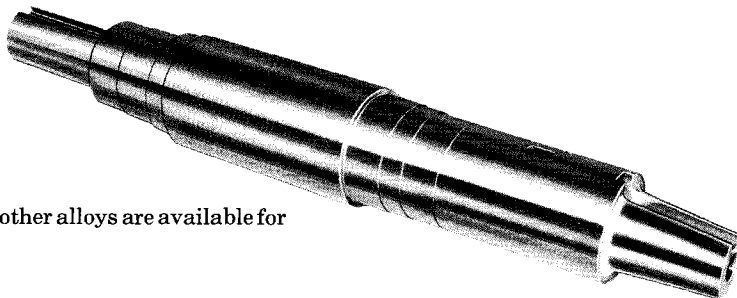

Precision machined shafts of stainless steel, monel and other alloys are available for difficult application.

**SLEEVES**

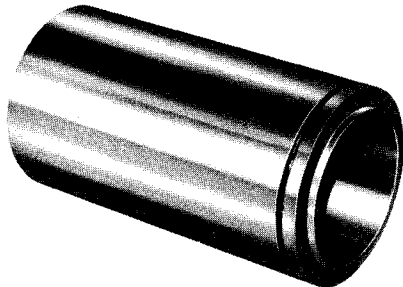

Shaft sleeves, machined to close tolerances are optionally available in either bronze, 316 stainless steel, or monel.

**WEAR RINGS**

Replaceable stainless steel wear rings available individually or together, protect the impeller and/or casing from wear. The rings are secured and aligned by 4 flat head machine screws that are easily removed. The ring running clearances are adjusted externally by the bearing cap. External flushing of the ring faces is available.

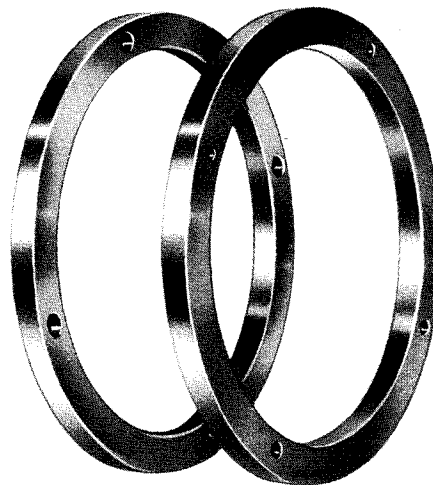

# AURORA MODEL 651A PUMP POWER FRAME 3C

SECTION 650 PAGE 201  
DATED NOVEMBER 1992  
SUPERSEDES PAGE 201  
DATED SEPTEMBER 1989

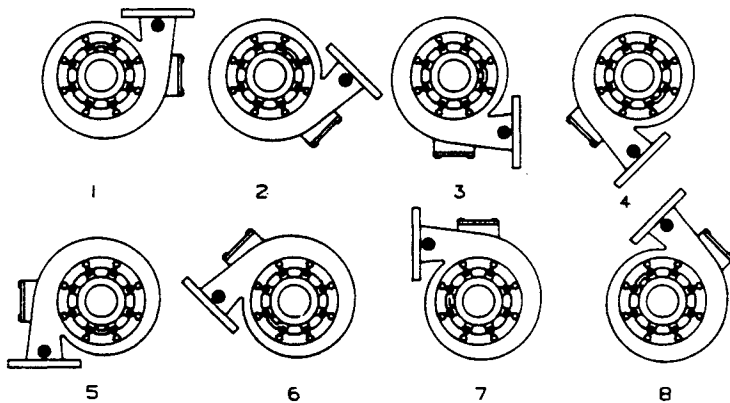
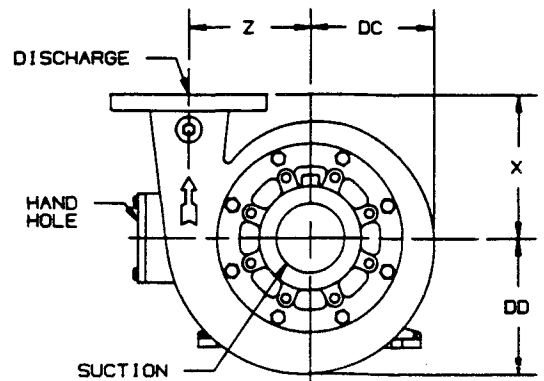
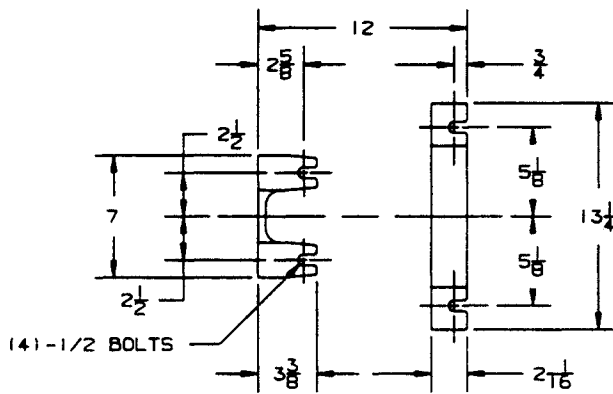
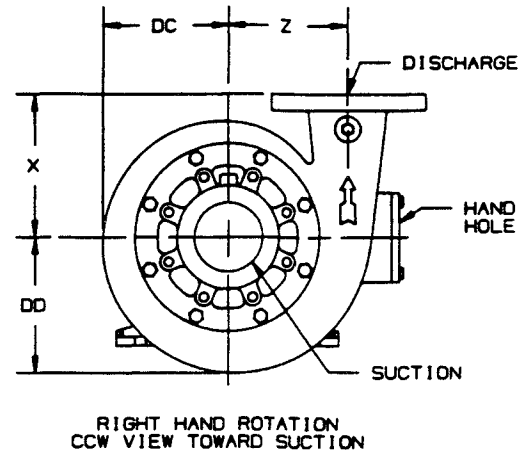
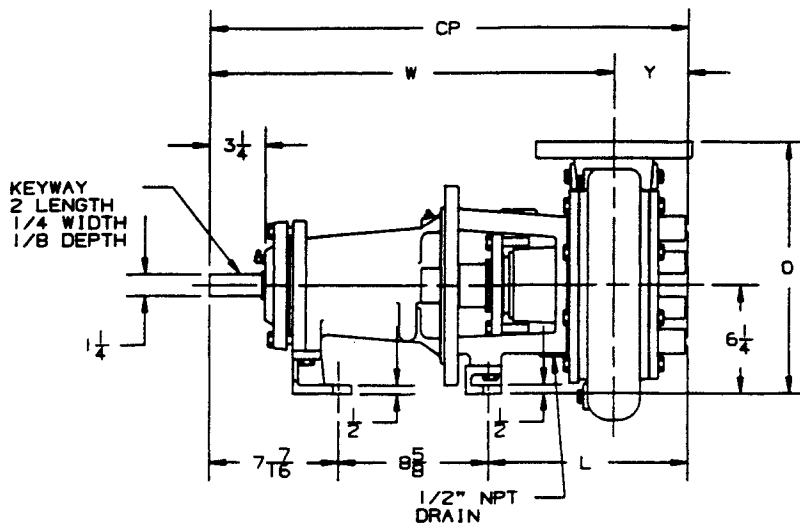

- NOTES:
1. ALL DIMENSIONS IN INCHES.
  2. DIMENSIONS MAY VARY  $\pm 1/4$ .
  3. NOT FOR CONSTRUCTION PURPOSES UNLESS CERTIFIED.
  4. TWO (2) 1/2" NPT CONNECTIONS 180° APART, ON THE STUFFING BOX FOR LUBRICATION PURPOSES ARE FURNISHED AS STANDARD. ON PACKED PUMPS AN ALEMITE FITTING IS PROVIDED IN ONE TAP AND THE REMAINING TAP IS PLUGGED.
  5. DISCHARGE POSITION 1 IS FURNISHED AS STANDARD UNLESS SPECIFIED.
  6. SUCTION AND DISCHARGE FLANGES ARE AMERICAN STANDARD 125 LBS.
  7. CHECK DISCHARGE POSITION, CASING DIMENSIONS WHICH EXCEED 6 1/4" MAY REQUIRE PADS FOR THE PUMP AND/OR MOTOR.
  8. 3x3x7 PUMP NOT AVAILABLE IN LEFT HAND CONFIGURATION.

DISCHARGE POSITIONS AVAILABLE  
(RIGHT HAND PUMP VIEWED FROM SUCTION END  
FOR LEFT HAND POSITIONS SEE PAGE 301)

DISCH SUCT CASE BORE POWER FRAME	L	O	W	X	Y	Z	CP	DC	DD
3x3x7	10 9/16	12 1/4	23 5/8	6	3	5	26 5/8	5 1/2	6 1/8
3x3x9	11 5/16	13 1/4	23 5/16	7	4 1/16	6 1/8	27 3/8	6 5/8	7 3/16
4x4x7	12 5/16	13 1/4	23 7/8	7	4 1/2	5 3/8	28 3/8	6	6 13/16
4x4x9A	11 7/16	14 1/2	23 1/4	8 1/4	4 1/4	7 1/16	27 1/2	7 1/4	7 13/16

# AURORA MODEL 651A PUMP

## POWER FRAMES 4C, 5E & 5F

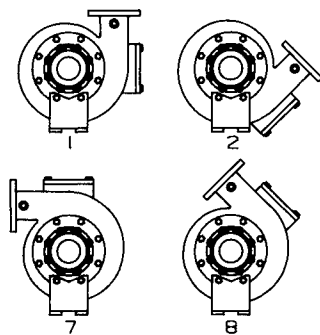
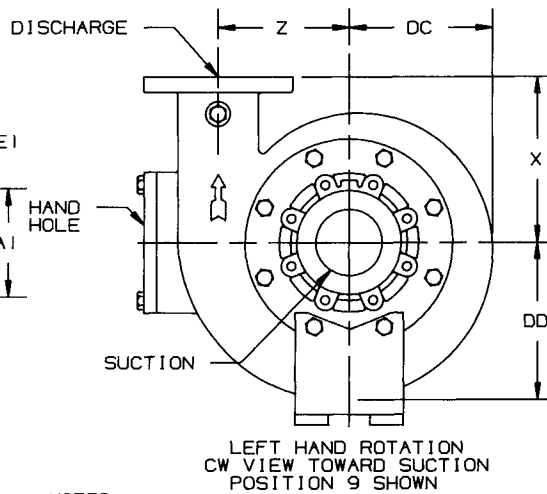
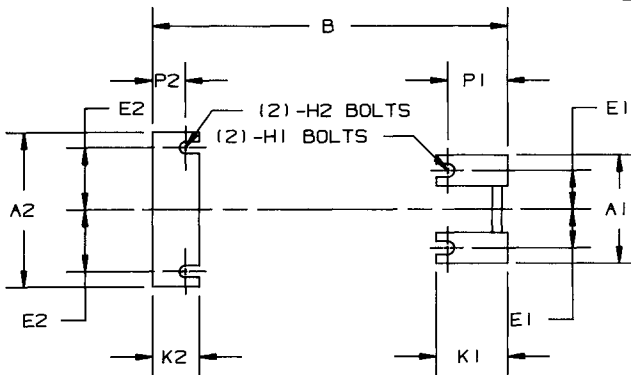
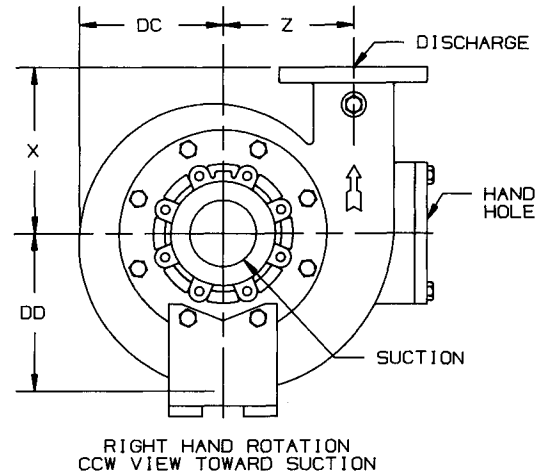
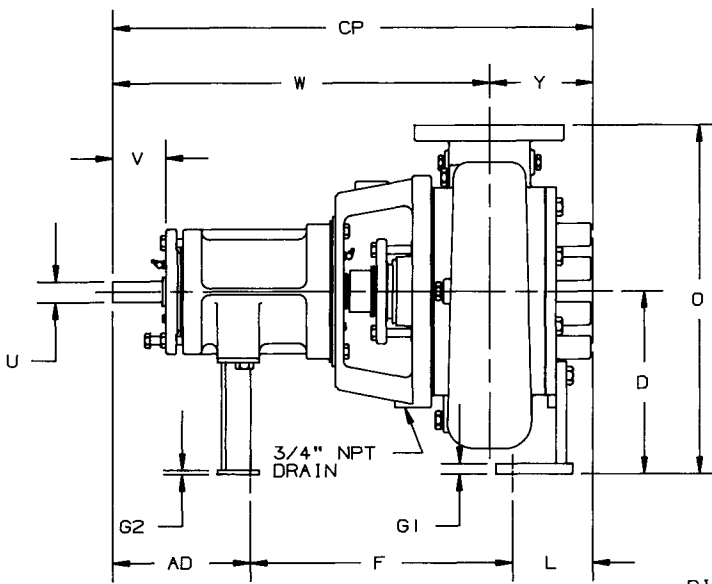

DISCHARGE POSITIONS AVAILABLE  
 (RIGHT HAND PUMP VIEWED FROM SUCTION END  
 FOR LEFT HAND POSITIONS SEE PAGE 3011)

- NOTES:
1. ALL DIMENSIONS IN INCHES.
  2. DIMENSIONS MAY VARY  $\pm 1/4$ .
  3. NOT FOR CONSTRUCTION PURPOSES UNLESS CERTIFIED.
  4. TWO (2) 1/2" NPT CONNECTIONS 180° APART, ON THE STUFFING BOX FOR LUBRICATION PURPOSES ARE FURNISHED AS STANDARD. ON PACKED PUMPS AN ALEMITE FITTING IS PROVIDED IN ONE TAP AND THE REMAINING TAP IS PLUGGED.
  5. DISCHARGE POSITION 1 IS FURNISHED AS STANDARD UNLESS SPECIFIED.
  6. SUCTION AND DISCHARGE FLANGES ARE AMERICAN STANDARD 125 LBS.

POWER FRAME	U	V	KEYWAY		
			LENGTH	WIDTH	DEPTH
4C	1 1/4	3 3/16	2	1/4	1/8
5E, 5F	2 3/8	6 3/8	4	5/8	5/16

DISCH SUCT CASE BORE	POWER FRAME	A1	A2	B	D	E1	E2	F	G1	G2	H1	H2	K1	K2
4x4x9B	4C	6 1/2	8 1/4	21 3/8	11	2 1/4	3 1/8	15 7/8	5/8	1/4	5/8	5/8	4 5/8	2 1/2
4x4x12	4C	7	10	21 3/8	13 1/2	2 1/2	4	15 3/8	5/8	3/8	5/8	5/8	4 5/8	3
4x4x12	5E	7	10	27 5/8	13 1/2	2 1/2	3 3/4	21	5/8	3/8	3/4	3/4	4 5/8	4
4x6x15	5E, 5F	11 1/2	11	27 15/16	15 1/4	4 1/4	4 1/4	19 11/16	5/8	3/8	3/4	3/4	7	3 1/2

DISCH SUCT CASE BORE	POWER FRAME	L	O	P1	P2	W	X	Y	Z	AD	CP	DC	DD
4x4x9B	4C	5 1/8	21	3 7/8	1 5/8	22 11/16	10	6 3/16	7 7/8	7 7/8	28 7/8	8 15/16	9 13/16
4x4x12	4C	5 1/8	25	3 7/8	2 1/8	22 5/8	10 1/2	6 1/4	9	8 3/8	28 7/8	9 7/8	10 3/8
4x4x12	5E	5 1/8	25	3 7/8	2 3/4	33 5/8	10 1/2	6 1/4	9	13 3/4	39 7/8	9 7/8	10 3/8
4x6x15	5E, 5F	6 7/16	25 3/4	6	2 1/4	33 5/16	10 1/2	6 3/16	10 1/4	13 3/8	39 1/2	11 1/8	11 5/8



# AURORA MODEL 652A PUMP

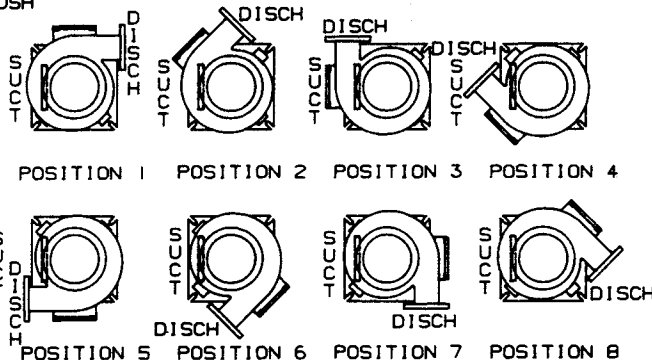
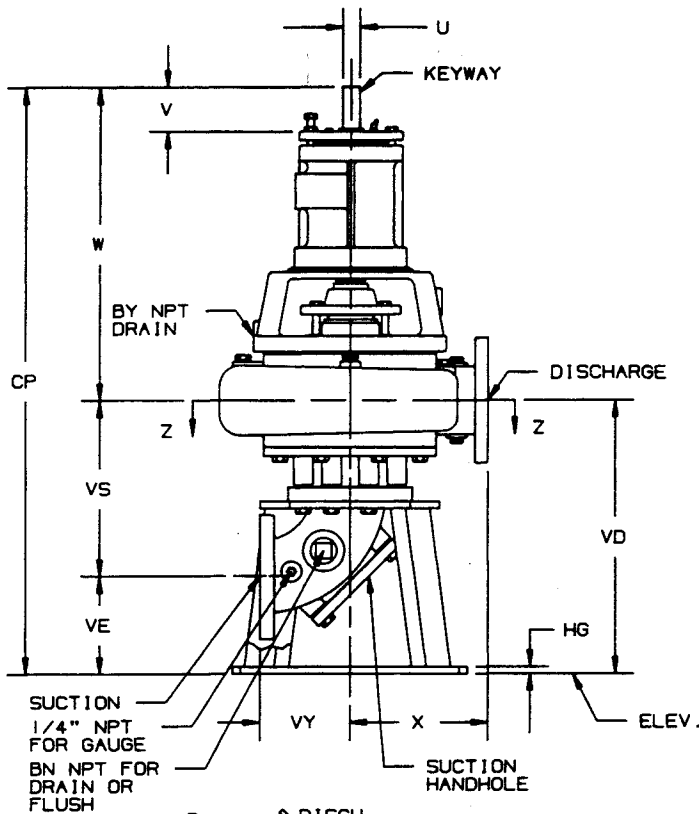

DISCHARGE POSITIONS AVAILABLE (RIGHT HAND PUMP VIEWED FROM DRIVER END FOR LEFT HAND POSITIONS SEE PAGE 302)

NOTE: PUMP SIZES 3x3x7 AND 3x3x9 DISCHARGE POSITIONS AVAILABLE ONLY IN 1, 3, 5, AND 7.

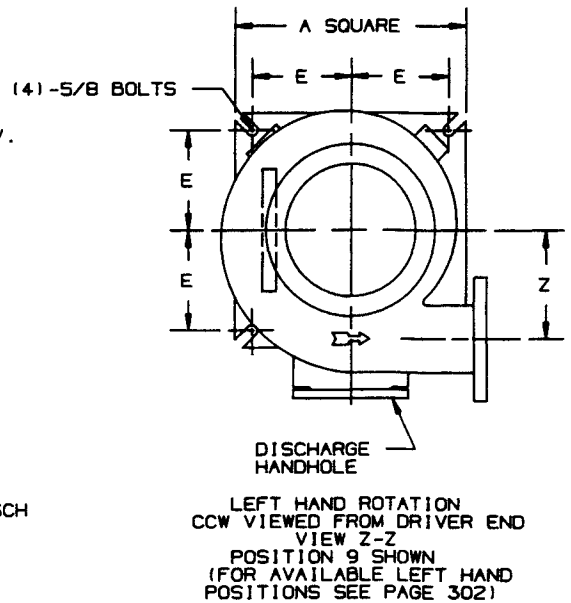
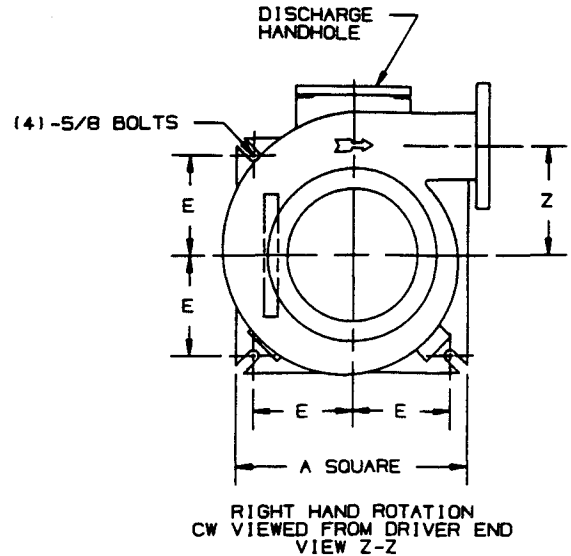

- NOTES:
1. ALL DIMENSIONS IN INCHES.
  2. DIMENSIONS MAY VARY ± 1/4".
  3. NOT FOR CONSTRUCTION PURPOSES UNLESS CERTIFIED.
  4. TWO (2) 1/2" NPT CONNECTIONS 180° APART, ON THE STUFFING BOX FOR LUBRICATION PURPOSES ARE FURNISHED AS STANDARD. ON PACKED PUMPS AN ALEMITE FITTING IS PROVIDED IN ONE TAP AND THE REMAINING TAP IS PLUGGED.
  5. DISCHARGE POSITION 1 IS FURNISHED AS STANDARD UNLESS SPECIFIED.
  6. SUCTION AND DISCHARGE FLANGES ARE AMERICAN STANDARD 125 LBS.
  7. 3x3x7 PUMP NOT AVAILABLE IN LEFT HAND CONFIGURATION.

POWER FRAME	U	V	KEYWAY		
			LENGTH	WIDTH	DEPTH
3C, 4C	1 1/4	3 3/16	2	1/4	1/8
5E, 5F	2 3/8	6 3/8	4	5/8	5/16

DISCH SUCT CASE BORE	POWER FRAME	A	BN	BY	E	HG	VY	W	X	Z	CP	VD	VE	VS
3x3x7	3C	17	1	1/2	7 1/4	1/2	6 1/2	23 5/8	6	5	39 7/8	16 1/4	6 3/4	9 1/2
3x3x9	3C	17	1	1/2	7 1/4	1/2	6 1/2	23 5/16	7	6 1/8	40 5/8	17 5/16	6 3/4	10 9/16
4x4x7	3C	17	1 1/2	1/2	7 1/4	1/2	6 1/2	23 7/8	7	5 3/8	41 7/8	18	6 15/16	11 1/16
4x4x9A	3C	17	1 1/2	1/2	7 1/4	1/2	6 1/2	23 1/4	8 1/4	7 1/16	41	17 3/4	6 15/16	10 13/16
4x4x9B	4C	17	1 1/2	3/4	7 1/4	1/2	6 1/2	22 11/16	10	7 7/8	42 3/8	19 11/16	6 15/16	12 3/4
4x4x12	4C	17	1 1/2	3/4	7 1/4	1/2	6 1/2	22 5/8	10 1/2	9	42 3/8	19 3/4	6 15/16	12 13/16
4x4x12	5E	17	1 1/2	3/4	7 1/4	1/2	6 1/2	33 5/8	10 1/2	9	53 3/8	19 3/4	6 15/16	12 13/16
4x6x15	5E, 5F	24	1 1/2	3/4	10 3/4	5/8	8	33 5/16	10 1/2	10 1/4	57 3/8	24 1/16	9 7/8	14 3/16

# AURORA MODEL 652A PUMP

## FLEXIBLE SHAFT

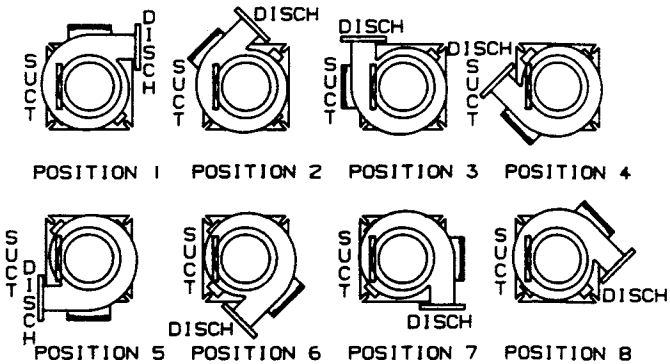
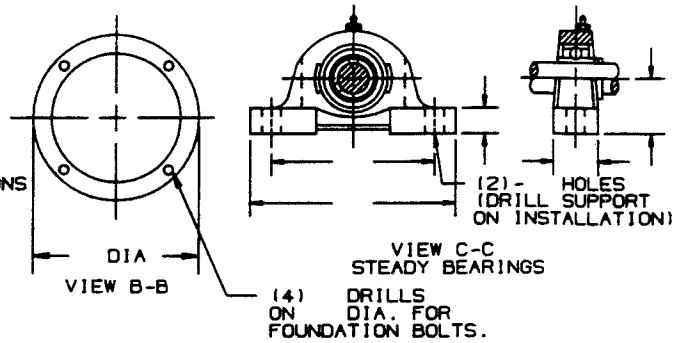
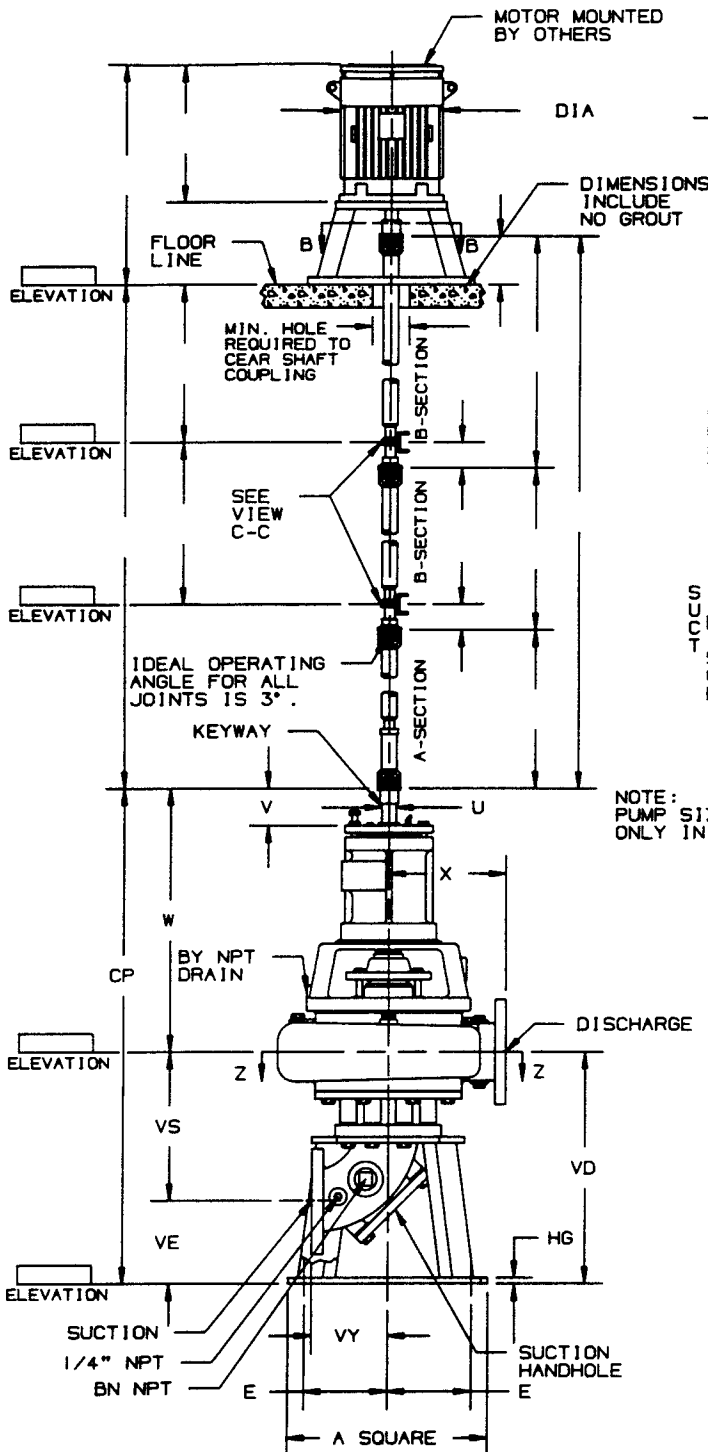

NOTE: PUMP SIZES 3x3x7 AND 3x3x9 DISCHARGE POSITIONS AVAILABLE ONLY IN 1, 3, 5, AND 7.

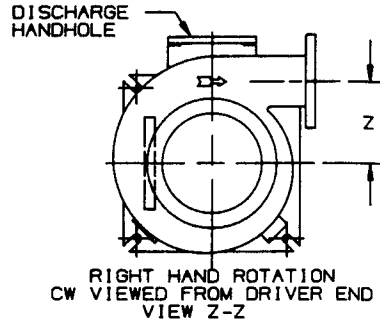

- NOTES:
- ALL DIMENSIONS IN INCHES.
  - DIMENSIONS MAY VARY ± 1/2"
  - NOT FOR CONSTRUCTION PURPOSES UNLESS CERTIFIED.
  - TWO (2) 1/2" NPT CONNECTIONS 180° APART, ON THE STUFFING BOX FOR LUBRICATION PURPOSES ARE FURNISHED AS STANDARD. ON PACKED PUMPS AN ALEMITE FITTING IS PROVIDED IN ONE TAP AND THE REMAINING TAP IS PLUGGED.
  - DISCHARGE POSITION 1 IS FURNISHED AS STANDARD UNLESS SPECIFIED.
  - SUCTION AND DISCHARGE FLANGES ARE AMERICAN STANDARD 125 LBS.
  - CONDUIT BOX IS SHOWN IS APPROXIMATE LOCATION. DIMENSIONS ARE NOT SPECIFIED AS THEY MAY VARY WITH EACH MOTOR MANUFACTURER.
  - 3x3x7 PUMP NOT AVAILABLE IN LEFT HAND CONFIGURATION.

DISCH SUCT CASE BORE	POWER FRAME	A	BN	BY	E	HG	VY	W	X	Z	CP	VD	VE	VS
3x3x7	3C	17	1	1/2	7 1/4	1/2	6 1/2	23 5/8	6	5	39 7/8	16 1/4	6 3/4	9 1/2
3x3x9	3C	17	1	1/2	7 1/4	1/2	6 1/2	23 5/16	7	6 1/8	40 5/8	17 5/16	6 3/4	10 9/16
4x4x7	3C	17	1 1/2	1/2	7 1/4	1/2	6 1/2	23 7/8	7	5 3/8	41 7/8	18	6 15/16	11 1/16
4x4x9A	3C	17	1 1/2	1/2	7 1/4	1/2	6 1/2	23 1/4	8 1/4	7 1/16	41	17 3/4	6 15/16	10 13/16
4x4x9B	4C	17	1 1/2	3/4	7 1/4	1/2	6 1/2	22 11/16	10	7 7/8	42 3/8	19 11/16	6 15/16	12 3/4
4x4x12	4C	17	1 1/2	3/4	7 1/4	1/2	6 1/2	22 5/8	9	10 1/2	42 3/8	19 3/4	6 15/16	12 13/16
4x4x12	5E	17	1 1/2	3/4	7 1/4	1/2	6 1/2	33 5/8	10 1/2	9	53 3/8	19 3/4	6 15/16	12 13/16
4x6x15	5E, 5F	24	1 1/2	3/4	10 3/4	5/8	8	33 5/16	10 1/2	10 1/4	57 3/8	24 1/16	9 7/8	14 3/16

POWER FRAME	U	V	KEYWAY		
			LENGTH	WIDTH	DEPTH
3C, 4C	1 1/4	3 3/16	2	1/4	1/8
5E, 5F	2 3/8	6 3/8	4	5/8	5/16

# AURORA MODEL 653A PUMP

SECTION 650 PAGE 205  
 DATED NOVEMBER 1992  
 SUPERSEDES PAGE 205  
 DATED SEPTEMBER 1989

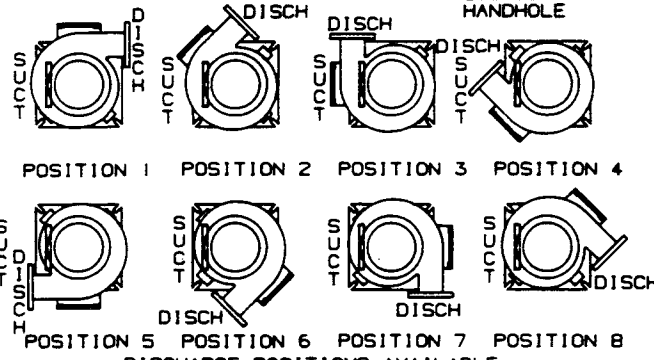
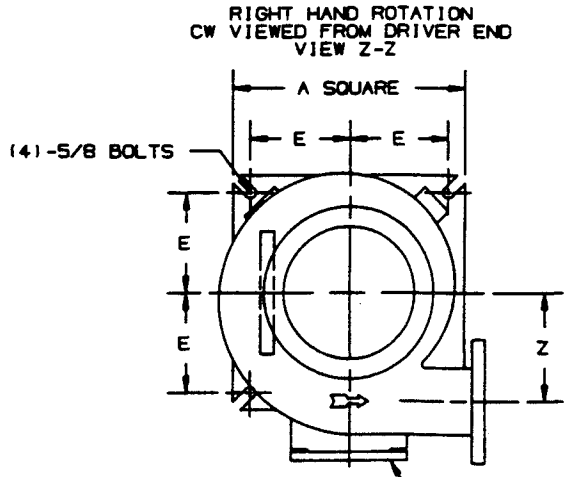
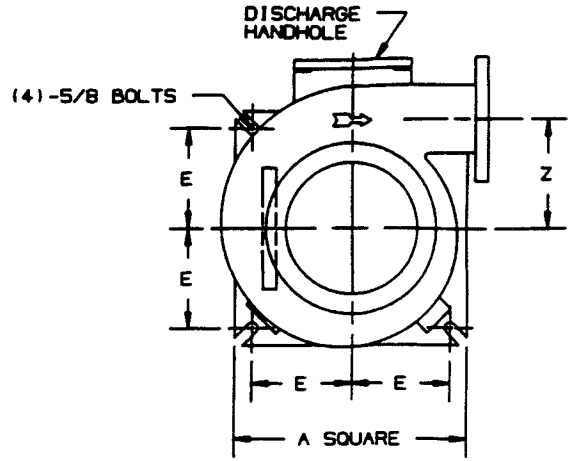
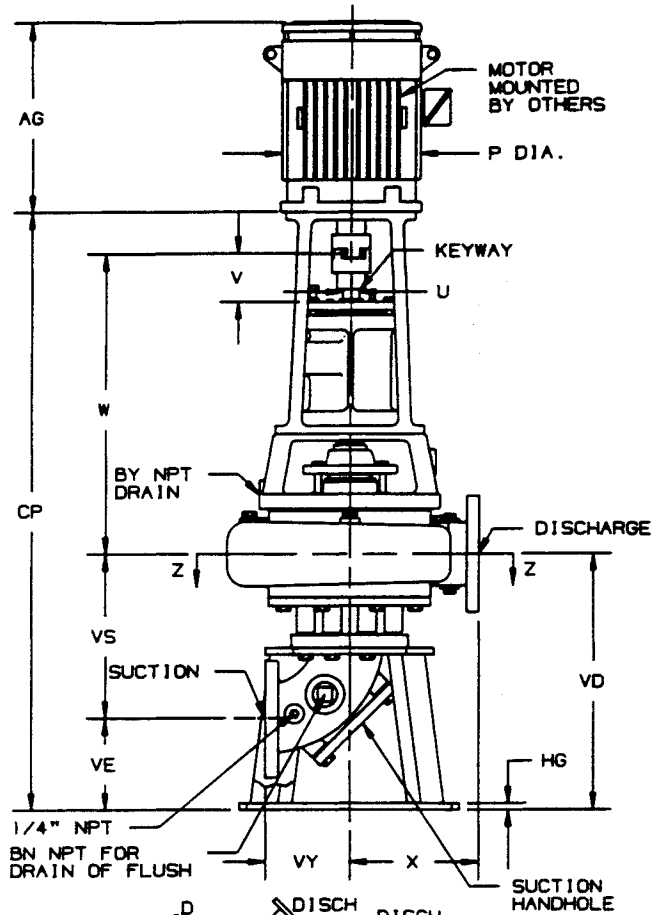

NOTE:  
 PUMP SIZE 3x3x7 AND 3x3x9 DISCHARGE POSITIONS AVAILABLE ONLY IN 1, 3, 5, AND 7.

- NOTES:
1. ALL DIMENSIONS IN INCHES.
  2. DIMENSIONS MAY VARY  $\pm 1/4"$ .
  3. NOT FOR CONSTRUCTION PURPOSES UNLESS CERTIFIED.
  4. TWO (2) 1/2" NPT CONNECTIONS 180° APART, ON THE STUFFING BOX FOR LUBRICATION PURPOSES ARE FURNISHED AS STANDARD. ON PACKED PUMPS AN ALEMITE FITTING IS PROVIDED IN ONE TAP AND THE REMAINING TAP IS PLUGGED.
  5. DISCHARGE POSITION 1 IS FURNISHED AS STANDARD UNLESS SPECIFIED.
  6. SUCTION AND DISCHARGE FLANGES ARE AMERICAN STANDARD 125 LBS.
  7. 3x3x7 PUMP NOT AVAILABLE IN LEFT HAND CONFIGURATION.

POWER FRAME	U	V	KEYWAY			P APPROX.	AG APPROX.	MOTOR FRAME												
			LENGTH	WIDTH	DEPTH			143HP TO 145HP	182HP TO 184HP	213HP TO 215HP	254HP TO 256HP	284HP TO 286HP	324HP TO 326HP	364HP TO 365HP	404HP TO 405HP					
3C, 4C	1 1/4	3 3/16	2	1/4	1/8	8	11	12	13	14	16	18	20	21	22	23	25	26	25	28
5E, 5F	2 3/8	6 3/8	4	5/8	5/16															

DISCH SUCT CASE BORE	POWER FRAME	A	BN	BY	E	HG	VY	W	X	Z	CP	VD	VE	VS
3x3x7	3C	17	1	1/2	7 1/4	1/2	6 1/2	23 5/8	6	5	43 1/2	16 1/4	6 3/4	9 1/2
3x3x9	3C	17	1	1/2	7 1/4	1/2	6 1/2	23 5/16	7	6 1/8	44 1/4	17 5/16	6 3/4	10 9/16
4x4x7	3C	17	1 1/2	1/2	7 1/4	1/2	6 1/2	23 7/8	7	5 3/8	45 1/2	18	6 15/16	11 1/16
4x4x9A	3C	17	1 1/2	1/2	7 1/4	1/2	6 1/2	23 1/4	8 1/4	7 1/16	44 5/8	17 3/4	6 15/16	10 13/16
4x4x9B	4C	17	1 1/2	3/4	7 1/4	1/2	6 1/2	22 11/16	10	7 7/8	46 1/8	19 11/16	6 15/16	12 3/4
4x4x12	4C	17	1 1/2	3/4	7 1/4	1/2	6 1/2	22 5/8	10 1/2	9	46 1/8	19 3/4	6 15/16	12 13/16
4x4x12	5E	17	1 1/2	3/4	7 1/4	1/2	6 1/2	33 5/8	10 1/2	9	58 7/8	19 3/4	6 15/16	12 13/16
4x6x15	5E, 5F	24	1 1/2	3/4	10 3/4	5/8	8	33 5/16	10 1/2	10 1/4	62 7/8	24 1/16	9 7/8	14 3/16



ADD 3/4" TO CP FOR PUMPS ON P.F. 4C WITH MOTOR FRAMES 284HPH TO 324HP. SUBTRACT 2" FROM CP FOR PUMPS ON P.F. 5E AND 5F WITH MOTOR FRAMES SMALLER THAN 284HPH.

# AURORA MODEL 654A PUMP

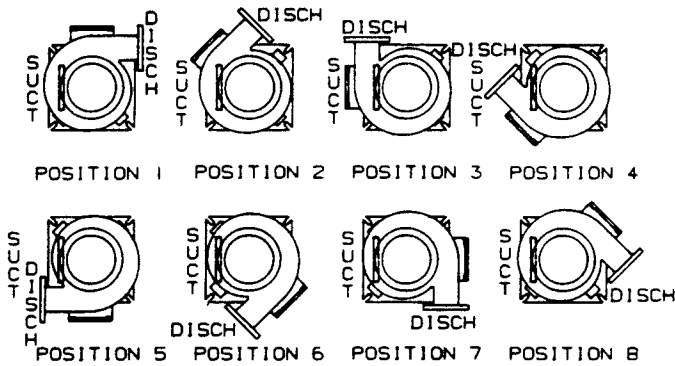
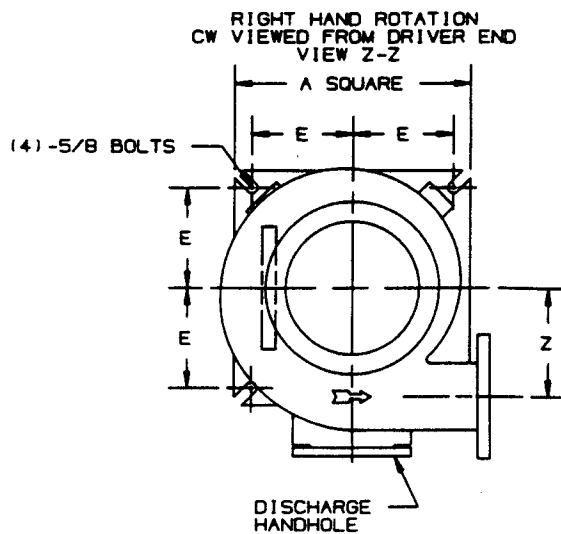
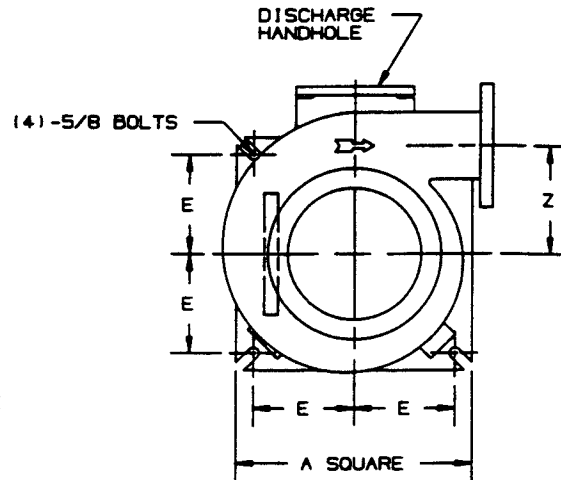
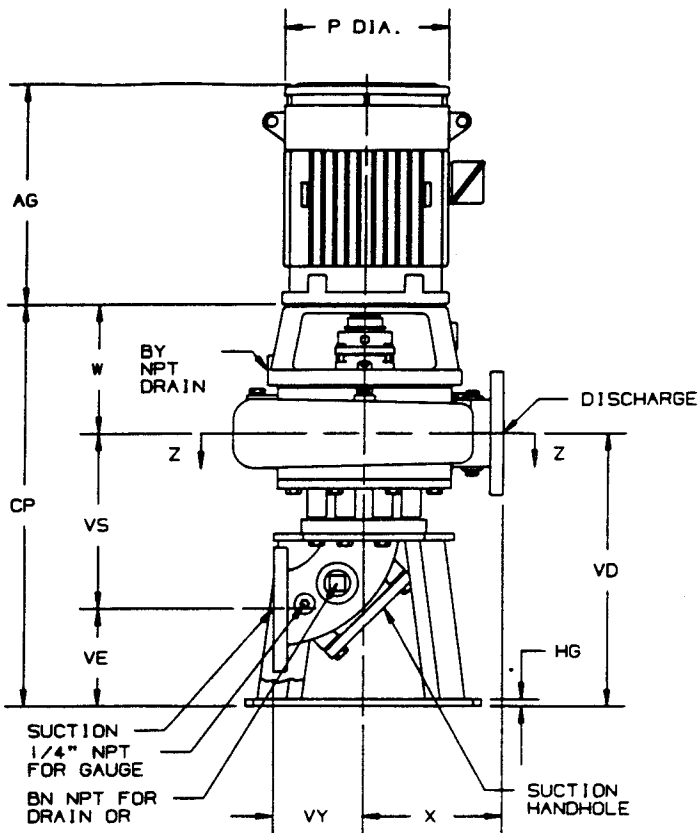

DISCHARGE POSITIONS AVAILABLE  
 (RIGHT HAND PUMP VIEWED FROM DRIVER END  
 FOR LEFT HAND POSITIONS SEE PAGE 302)

NOTE:  
 PUMP SIZES 3x3x7 AND 3x3x9 DISCHARGE POSITIONS AVAILABLE ONLY IN 1, 3, 5, AND 7.

MOTOR FRAME	143TCV TO 145TCV	182TCV TO 184TCV	213TCV TO 215TCV	254TCV TO 256TCV	284TCV TO 286TCV	324TCV TO 326TCV	364TCV TO 365TCV	404TCV TO 405TCV
P APPROX.	8	10	11	13	16	18	21	22
AG APPROX.	11 12	13 14	16 18	20 21	22 23	25 26	25	28

- NOTES:
- ALL DIMENSIONS IN INCHES.
  - DIMENSIONS MAY VARY  $\pm 1/4"$ .
  - NOT FOR CONSTRUCTION PURPOSES UNLESS CERTIFIED.
  - TWO (2) 1/2" NPT CONNECTIONS 180° APART, ON THE STUFFING BOX FOR LUBRICATION PURPOSES ARE FURNISHED AS STANDARD.
  - DISCHARGE POSITION 1 IS FURNISHED AS STANDARD UNLESS SPECIFIED.
  - SUCTION AND DISCHARGE FLANGES ARE AMERICAN STANDARD 125 LBS.
  - HEIGHT (AG) AND DIAMETERS (P) DIMENSIONS OF MOTOR WILL VARY BASED ON MAKE AND STYLE OF MOTOR. DIMENSIONS SHOWN REFLECT AURORA STANDARD MOTORS. SEE INDIVIDUAL MOTOR SUPPLIER DIMENSIONAL DATA SHEETS FOR YOUR APPLICATION. CONDUIT BOX IS SHOWN IN APPROXIMATE LOCATION. DIMENSIONS ARE NOT SPECIFIED AS THEY VARY WITH EACH MOTOR MANUFACTURER.
  - 3x3x7 PUMP NOT AVAILABLE IN LEFT HAND CONFIGURATION.

DISCH SUCT CASE BORE MOTOR SHAFT EXT. TYPE	A	BN	BY	E	HG	VY	W	X	Z	CP	VD	VE	VS
3x3x7 3C, 4C	17	1	1/2	7 1/4	1/2	6 1/2	10 5/16	6	5	26 9/16	16 1/4	6 3/4	9 1/2
3x3x9 3C, 4C	17	1	1/2	7 1/4	1/2	6 1/2	10	7	6 1/8	27 5/16	17 5/16	6 3/4	10 9/16
4x4x7 3C, 4C	17	1 1/2	1/2	7 1/4	1/2	6 1/2	10 9/16	7	5 3/8	28 9/16	18	6 15/16	11 1/16
4x4x9A 3C, 4C	17	1 1/2	1/2	7 1/4	1/2	6 1/2	9 15/16	8 1/4	7 1/16	27 11/16	17 3/4	6 15/16	10 13/16
4x4x9B 3C, 4C	17	1 1/2	3/4	7 1/4	1/2	6 1/2	9 1/2	10	7 7/8	29 3/16	19 11/16	6 15/16	12 3/4
4x4x12 3C, 4C	17	1 1/2	3/4	7 1/4	1/2	6 1/2	9 7/16	10 1/2	9	29 3/16	19 3/4	6 15/16	12 13/16
4x4x12 5E, 5F	17	1 1/2	3/4	7 1/4	1/2	6 1/2	10 5/8	10 1/2	9	30 3/8	19 3/4	6 15/16	12 13/16
4x6x15 5E, 5F	24	1 1/2	3/4	10 3/4	5/8	8	10 5/16	10 1/2	10 1/4	34 3/8	24 1/16	9 7/8	14 3/16

# AURORA MODEL 651A PUMP

## POWER FRAME 3C FORMED STEEL BASE

SECTION 650 PAGE 251  
DATED NOVEMBER 1992  
SUPERSEDES PAGE 251  
DATED SEPTEMBER 1989

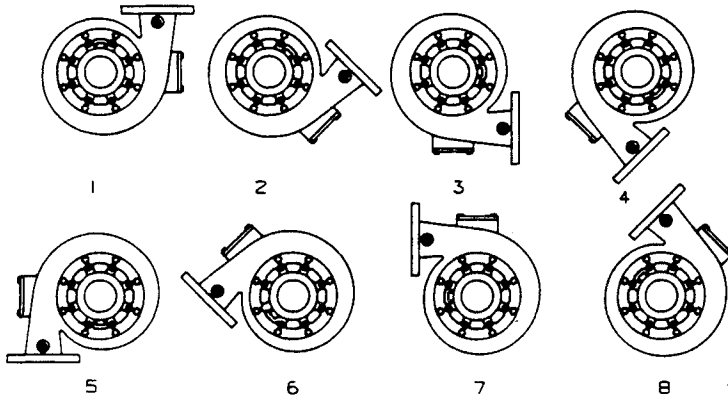
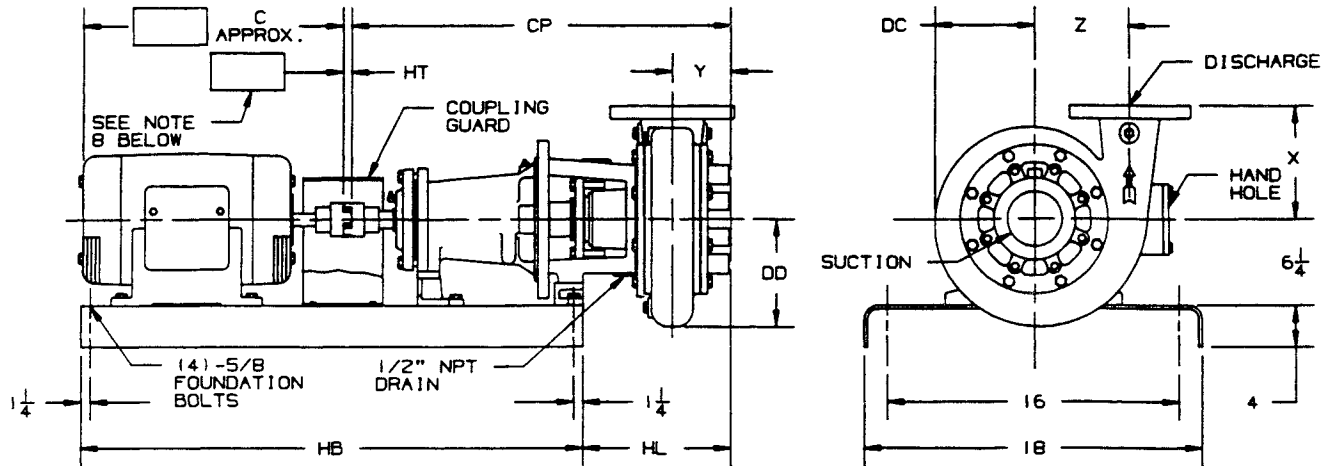

DISCHARGE POSITIONS AVAILABLE  
(RIGHT HAND PUMP VIEWED FROM SUCTION END  
FOR LEFT HAND POSITIONS SEE PAGE 301)

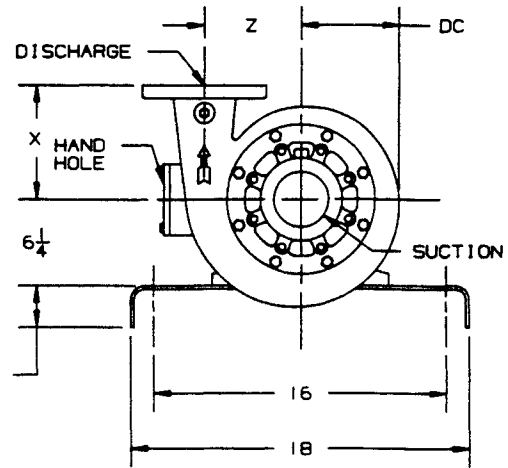

LEFT HAND ROTATION  
CW VIEW TOWARD SUCTION  
POSITION 9 SHOWN  
(FOR AVAILABLE LEFT HAND  
POSITIONS SEE PAGE 301)

**NOTES:**

1. ALL DIMENSIONS IN INCHES.
2. DIMENSIONS MAY VARY  $\pm 1/4"$ .
3. NOT FOR CONSTRUCTION PURPOSES UNLESS CERTIFIED.
4. TWO (2)  $1/2"$  NPT CONNECTIONS  $180^\circ$  APART, ON THE STUFFING BOX FOR LUBRICATION PURPOSES ARE FURNISHED AS STANDARD. ON PACKED PUMPS AN ALEMITE FITTING IS PROVIDED IN ONE TAP AND THE REMAINING TAP IS PLUGGED.
5. DISCHARGE POSITION 1 IS FURNISHED AS STANDARD UNLESS SPECIFIED.
6. SUCTION AND DISCHARGE FLANGES ARE AMERICAN STANDARD 125 LBS.
7. CONDUIT BOX IS SHOWN IS APPROXIMATE LOCATION. DIMENSIONS ARE NOT SPECIFIED AS THEY MAY VARY WITH EACH MOTOR MANUFACTURER.
8. STANDARD COUPLING ILLUSTRATED. "HT" DIMENSION MAY VARY  $1/8"$  TO  $1"$ . SPACER COUPLING "HT" DIMENSION IS  $3 1/2"$ .
9.  $3 \times 3 \times 7$  PUMP NOT AVAILABLE IN LEFT HAND CONFIGURATION.

MOTOR FRAME	C APPROX.	HB	
		STD. CPLG.	SPCR. CPLG.
56	12	38	38
143T	11	38	38
145T	12	38	38
182T	13	38	38
184T	14	38	38
213T	16	38	38
215T	18	38	38
254T	21	38	42

DISCH SUCTION CORE POWER FRAME	HL	X	Y	Z	CP	DC	DD	
3x3x7	3C	9 13/16	6	3	5	26 5/8	5 1/2	6 1/8
3x3x9	3C	10 9/16	7	4 1/16	6 1/8	27 3/8	6 5/8	7 3/16
4x4x7	3C	11 9/16	7	4 1/2	5 3/8	28 3/8	6	6 13/16
4x4x9A	3C	10 11/16	8 1/4	4 1/4	7 1/16	27 1/2	7 1/4	7 13/16

# AURORA MODEL 651A PUMP

## POWER FRAMES 4C, 5E & 5F FORMED STEEL BASE

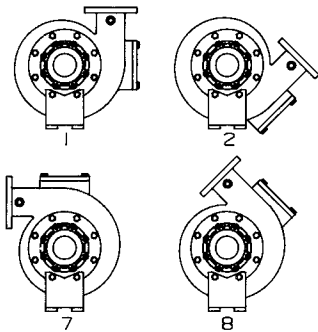
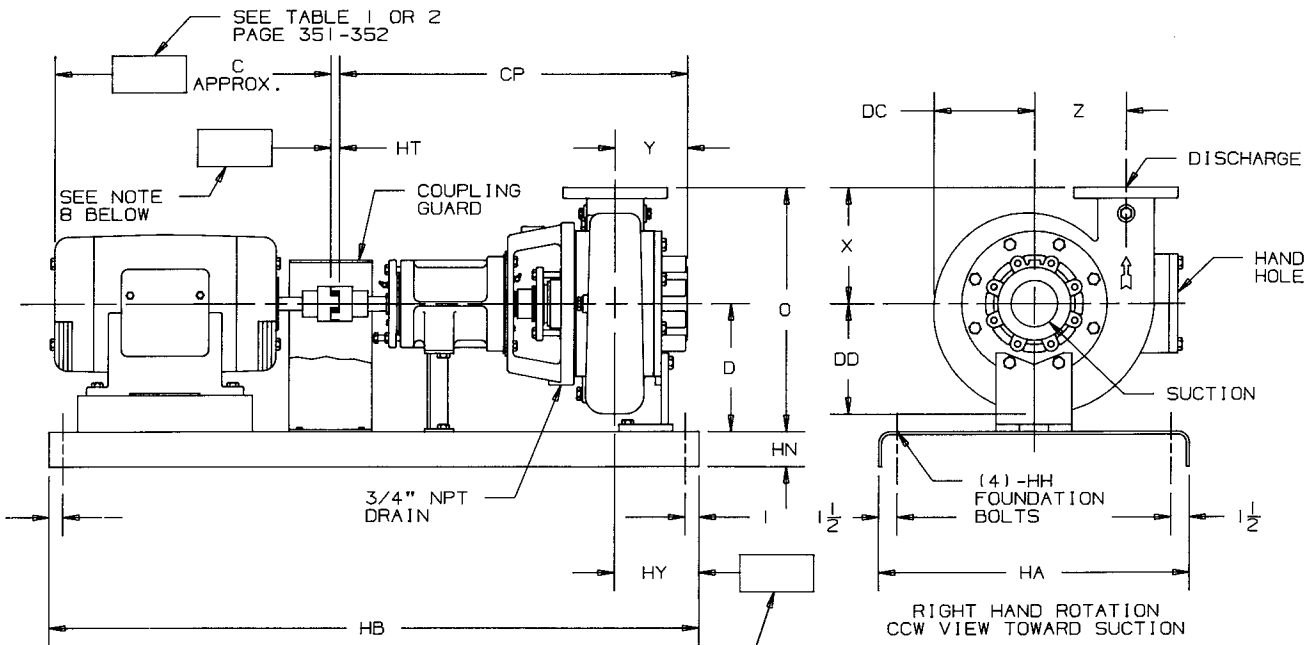

DISCHARGE POSITIONS AVAILABLE  
 (RIGHT HAND PUMP VIEWED FROM SUCTION END  
 FOR LEFT HAND POSITIONS SEE PAGE 301)

SEE TABLE 1 OR 2  
 PAGE 351-352

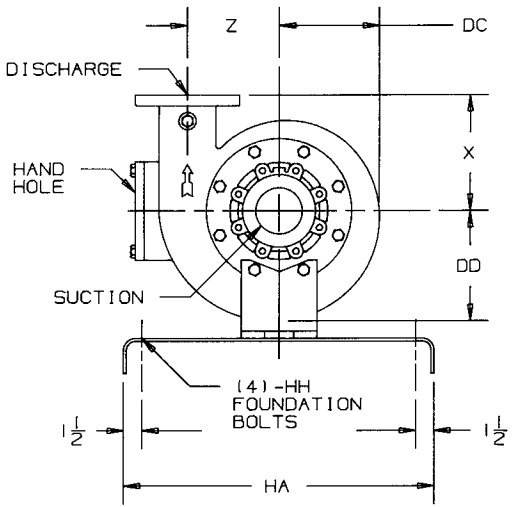

LEFT HAND ROTATION  
 CW VIEW TOWARD SUCTION  
 POSITION 9 SHOWN  
 (FOR AVAILABLE LEFT HAND  
 POSITIONS SEE PAGE 301)

- NOTES:
1. ALL DIMENSIONS IN INCHES.
  2. DIMENSIONS MAY VARY  $\pm 1/4"$ .
  3. NOT FOR CONSTRUCTION PURPOSES UNLESS CERTIFIED.
  4. TWO (2)  $1/2"$  NPT CONNECTIONS  $180^\circ$  APART, ON THE STUFFING BOX FOR LUBRICATION PURPOSES ARE FURNISHED AS STANDARD. ON PACKED PUMPS AN ALEMITE FITTING IS PROVIDED IN ONE TAP AND THE REMAINING TAP IS PLUGGED.
  5. DISCHARGE POSITION 1 IS FURNISHED AS STANDARD UNLESS SPECIFIED.
  6. SUCTION AND DISCHARGE FLANGES ARE AMERICAN STANDARD 125 LBS.
  7. CONDUIT BOX IS SHOWN IS APPROXIMATE LOCATION. DIMENSIONS ARE NOT SPECIFIED AS THEY MAY VARY WITH EACH MOTOR MANUFACTURER.
  8. STANDARD COUPLING ILLUSTRATED. "HT" DIMENSION 1" MAXIMUM. FOR SPACER COUPLING SIZE AND "HT" DIMENSION REFER TO PAGE 353 (TABLE 3).

BASE	HA	HB	HH	HN
2	15	48	5/8	3 3/8
3	15	54	5/8	3 3/8
4	15	60	5/8	3 3/8
5	15	64	5/8	3 3/8
6	15	70	5/8	3 3/8
8	18	68	5/8	4
9	18	76	5/8	4
16	22	72	5/8	4
17	22	84	5/8	4

DISCH SUCT CASE CODE	POWER FRAME	D	O	X	Y	Z	CP	DC	DD
4x4x9B	4C	11	21	10	6 3/16	7 7/8	28 7/8	8 15/16	9 13/16
4x4x12	4C	13 1/2	25	10 1/2	6 1/4	9	28 7/8	9 7/8	10 3/8
4x4x12	5E	13 1/2	25	10 1/2	6 1/4	9	39 7/8	9 7/8	10 3/8
4x6x15	5E, 5F	15 1/4	25 3/4	10 1/2	6 3/16	10 1/4	39 1/2	11 1/8	11 5/8

# AURORA MODEL 651A PUMP

SECTION 650 PAGE 253

## POWER FRAME 3C DRIP RIM STEEL BASE

DATED MARCH 1992

SUPERSEDES PAGE 253  
DATED SEPTEMBER 1989

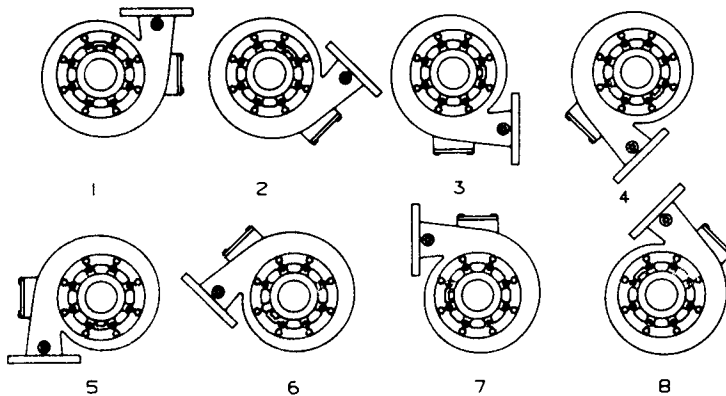
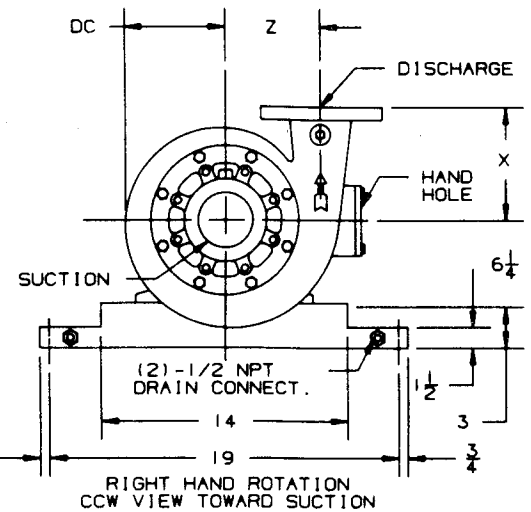
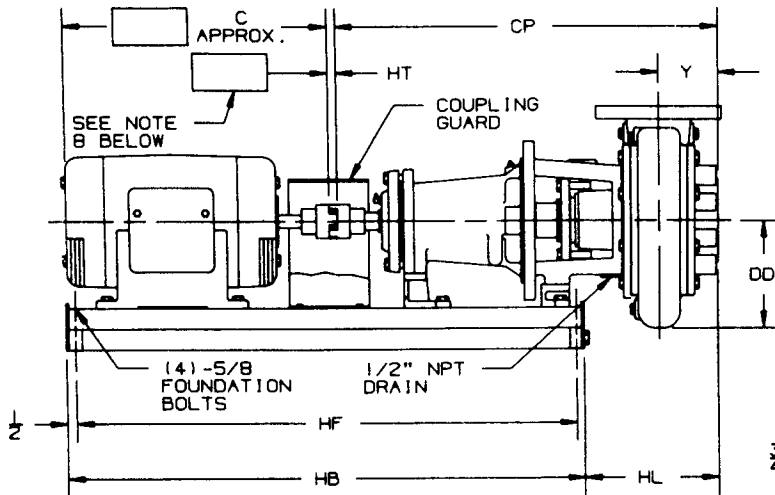

DISCHARGE POSITIONS AVAILABLE  
(RIGHT HAND PUMP VIEWED FROM SUCTION END  
FOR LEFT HAND POSITIONS SEE PAGE 3011)

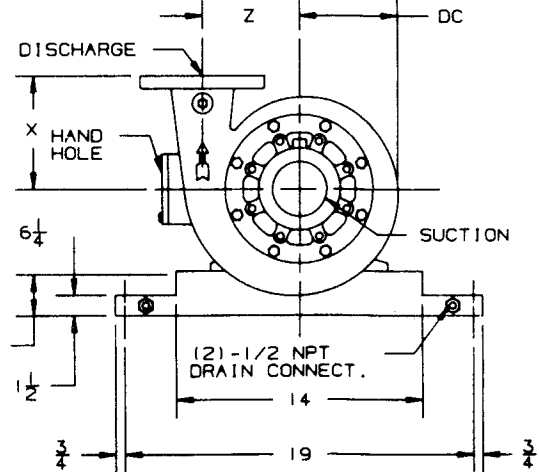

**NOTES:**

1. ALL DIMENSIONS IN INCHES.
2. DIMENSIONS MAY VARY  $\pm 1/4"$ .
3. NOT FOR CONSTRUCTION PURPOSES UNLESS CERTIFIED.
4. TWO (2) 1/2" NPT CONNECTIONS 180° APART, ON THE STUFFING BOX FOR LUBRICATION PURPOSES ARE FURNISHED AS STANDARD. ON PACKED PUMPS AN ALEMITE FITTING IS PROVIDED IN ONE TAP AND THE REMAINING TAP IS PLUGGED.
5. DISCHARGE POSITION 1 IS FURNISHED AS STANDARD UNLESS SPECIFIED.
6. SUCTION AND DISCHARGE FLANGES ARE AMERICAN STANDARD 125 LBS.
7. CONDUIT BOX IS SHOWN IS APPROXIMATE LOCATION. DIMENSIONS ARE NOT SPECIFIED AS THEY MAY VARY WITH EACH MOTOR MANUFACTURER.
8. STANDARD COUPLING ILLUSTRATED. "HT" DIMENSION MAY VARY 1/8" TO 1". SPACER COUPLING "HT" DIMENSION IS 3 1/2".
9. 3x3x7 PUMP NOT AVAILABLE IN LEFT HAND CONFIGURATION.

BASE	SIZE	HB	HF
7	14x36	36 1/2	35
8	14x46	42 1/2	41

MOTOR FRAME	C APPROX.	BASE	
		STD. CPLG.	SPCR. CPLG.
56	12	7	7
143T	11	7	7
145T	12	7	7
182T	13	7	7
184T	14	7	7
213T	16	7	7
215T	18	7	8
254T	21	8	8

DISCH SUCTION CASE BORE	POWER FRAME	HL	X	Y	Z	CP	DC	DD
3x3x7	3C	9 5/16	6	3	5	26 5/8	5 1/2	6 1/8
3x3x9	3C	10 1/4	7	4 1/16	6 1/8	28 3/8	6 5/8	7 3/16
4x4x7	3C	11 1/16	7	4 1/2	5 3/8	28 3/8	6	6 13/16
4x4x9A	3C	10 3/16	8 1/4	4 1/4	7 1/16	27 1/2	7 1/4	7 13/16

SECTION 650 PAGE 254 — **AURORA MODEL 651A PUMP**

DATED NOVEMBER 1996

SUPERSEDES PAGE 254

DATED MARCH 1992

**POWER FRAMES 4C, 5E & 5F**

**DRIP RIM STEEL BASE**

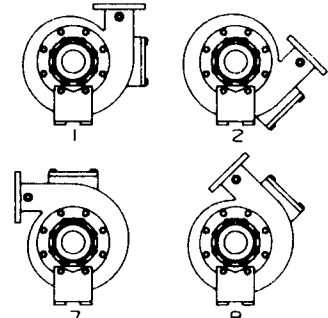
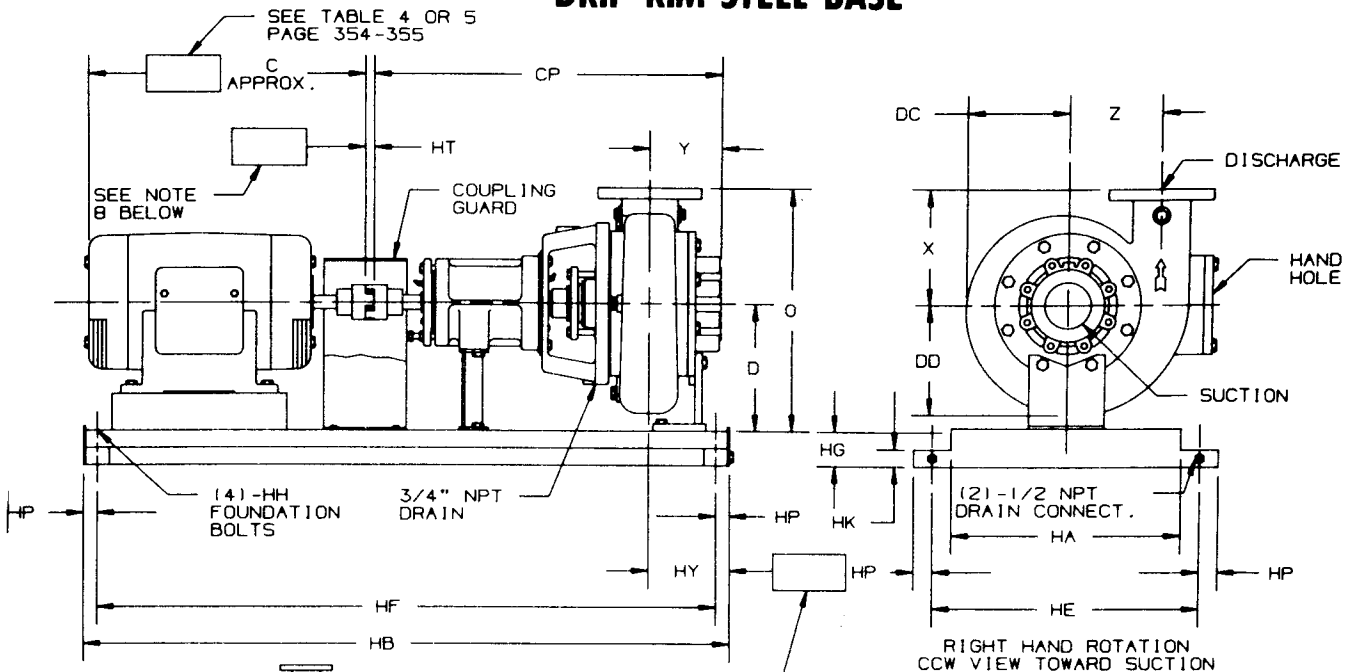

DISCHARGE POSITIONS AVAILABLE  
(RIGHT HAND PUMP VIEWED FROM SUCTION END  
FOR LEFT HAND POSITIONS SEE PAGE 301)

NOTES:

1. ALL DIMENSIONS IN INCHES.
2. DIMENSIONS MAY VARY  $\pm 1/4$ ".
3. NOT FOR CONSTRUCTION PURPOSES UNLESS CERTIFIED.
4. TWO (2) 1/2" NPT CONNECTIONS 180° APART, ON THE STUFFING BOX FOR LUBRICATION PURPOSES ARE FURNISHED AS STANDARD. ON PACKED PUMPS AN ALEMITE FITTING IS PROVIDED IN ONE TAP AND THE REMAINING TAP IS PLUGGED.
5. DISCHARGE POSITION 1 IS FURNISHED AS STANDARD UNLESS SPECIFIED.
6. SUCTION AND DISCHARGE FLANGES ARE AMERICAN STANDARD 125 LBS.
7. CONDUIT BOX IS SHOWN IS APPROXIMATE LOCATION. DIMENSIONS ARE NOT SPECIFIED AS THEY MAY VARY WITH EACH MOTOR MANUFACTURER.
8. STANDARD COUPLING ILLUSTRATED. "HT" DIMENSION 1" MAXIMUM. FOR SPACER COUPLING SIZE AND "HT" DIMENSION REFER TO PAGE 353 (TABLE 3).
9. 3 GROUT HOLES ARE PROVIDED IN TOP OF BASE.

BASE	SIZE	HA	HB	HE	HF	HG	HH	HK	HP
9	14x48	14	48 1/2	19	47	3	5/8	1 1/2	3/4
10	14x56	14	56 1/2	19	55	3	5/8	1 1/2	3/4
13	18x64	18	64 1/2	25 1/8	62 7/8	4	3/4	2	13/16
14	18x72	18	72 1/2	25 1/8	70 7/8	4	3/4	2	13/16
17	22x74	22	74 1/2	29 1/8	72 7/8	4 1/2	3/4	2	13/16
18	22x82	22	82 1/2	29 1/8	80 7/8	4 1/2	3/4	2	13/16

DISCH SUCT CASE BORE	POWER FRAME	D	O	X	Y	Z	CP	DC	DD
4x4x9B	4C	11	21	10	6 3/16	7 7/8	28 7/8	8 15/16	9 13/16
4x4x12	4C	13 1/2	25	10 1/2	6 1/4	9	28 7/8	9 7/8	10 3/8
4x4x12	5E	13 1/2	25	10 1/2	6 1/4	9	39 7/8	9 7/8	10 3/8
4x6x15	5E, 5F	15 1/4	25 3/4	10 1/2	6 3/16	10 1/4	39 1/2	11 1/8	11 5/8



**LEFT HAND DISCHARGE POSITIONS**

**3 x 3 x 9, 4 x 4 x 7 AND 4 x 4 x 9A ONLY**

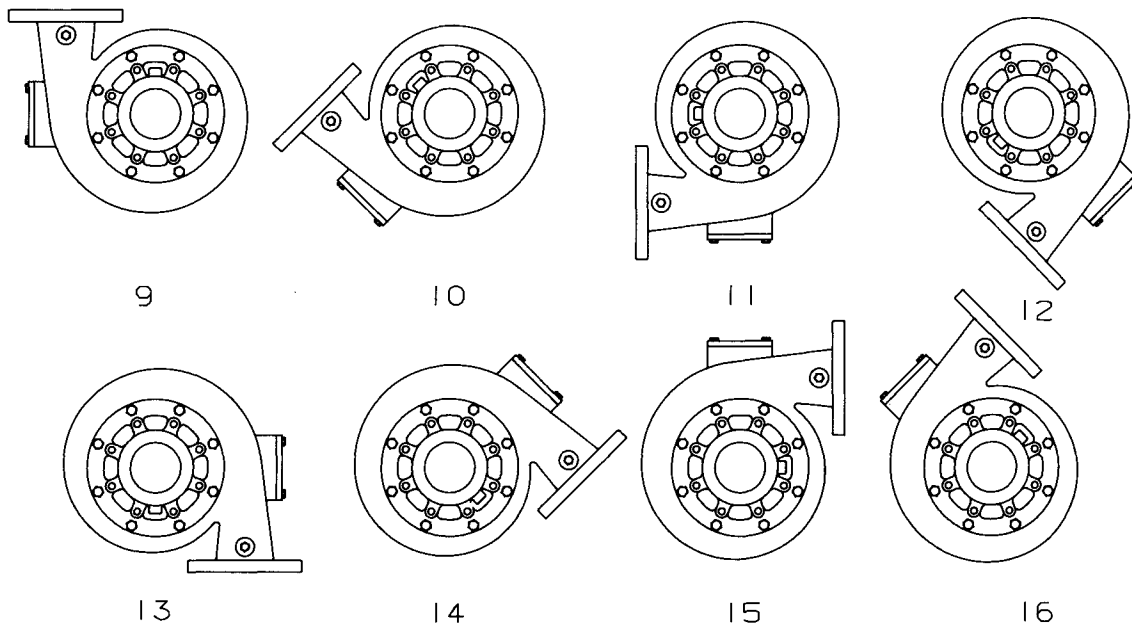

DISCHARGE POSITIONS AVAILABLE  
(LEFT HAND PUMP VIEWED FROM SUCTION END)

**NOTES:**

1. THIS PAGE IS FOR LEFT HAND DISCHARGE POSITIONS; FOR RIGHT HAND POSITIONS REFER TO INDIVIDUAL DIMENSION PAGES.
2. THE 3x3x7 PUMP IS NOT AVAILABLE IN LEFT HAND CONFIGURATION.
3. THE ABOVE EIGHT POSITIONS ARE ONLY AVAILABLE ON THE FOLLOWING PUMPS: 3x3x9, 4x4x7, AND 4x4x9A.
4. THE BELOW FOUR POSITIONS ARE THE ONLY AVAILABLE POSITIONS ON THE FOLLOWING PUMPS: 4x4x9B, 4x4x12, AND 4x6x15.

**4 x 4 x 9B, 4 x 4 x 12 AND 4 x 6 x 15 ONLY**

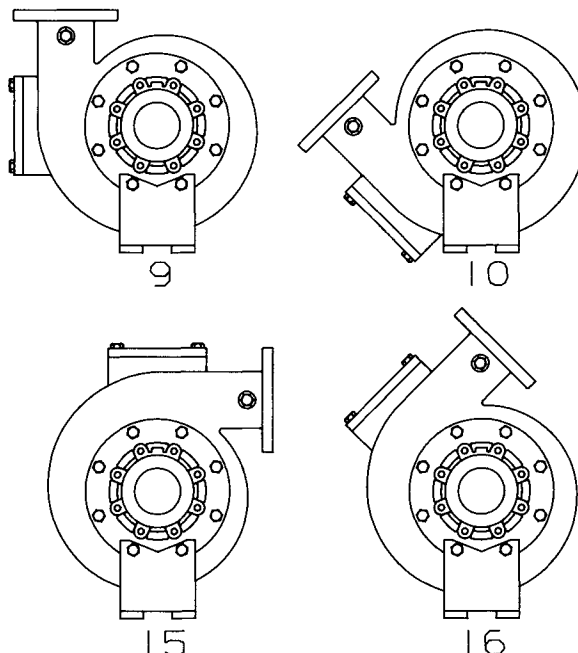

DISCHARGE POSITIONS AVAILABLE  
(LEFT HAND PUMP VIEWED FROM SUCTION END)

# AURORA MODEL 652A, 653A, 654A PUMP

## LEFT HAND DISCHARGE POSITIONS

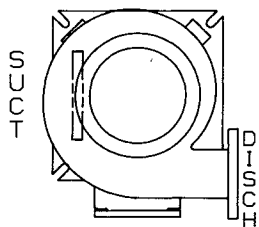

POSITION 9

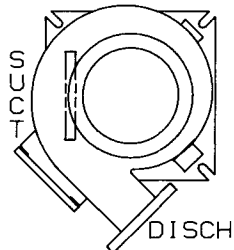

POSITION 10

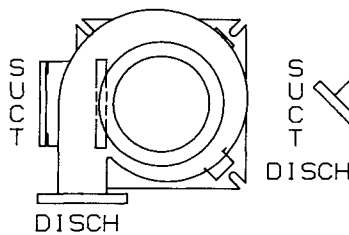

POSITION 11

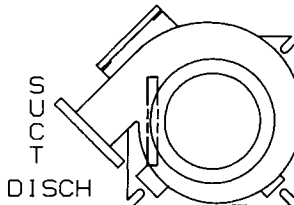

POSITION 12

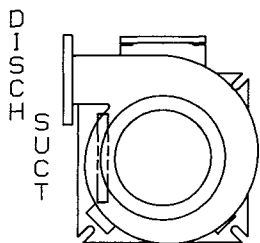

POSITION 13

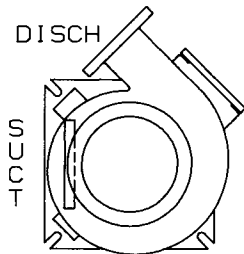

POSITION 14

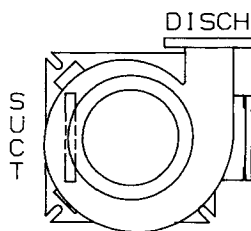

POSITION 15

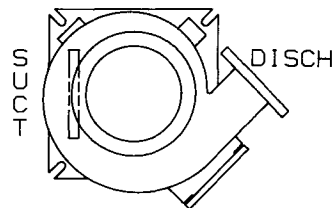

POSITION 16

DISCHARGE POSITIONS AVAILABLE  
(LEFT HAND PUMP VIEWED FROM DRIVER END)

NOTES:

1. THIS PAGE IS FOR LEFT HAND DISCHARGE POSITIONS; FOR RIGHT HAND POSITIONS REFER TO INDIVIDUAL DIMENSION PAGES.
2. THE 3x3x7 PUMP IS NOT AVAILABLE IN LEFT HAND CONFIGURATION.
3. THE 3x3x9 PUMP IS AVAILABLE ONLY IN POSITIONS 9, 11, 13, AND 15.

# AURORA MODEL 651A PUMP FORMED STEEL BASE STANDARD COUPLING

TABLE I

CASE BORE DISCH.	POWER SERIES	MOTOR FRAME	182T	184T	213T	215T	254T	256T	284TS	284T	286TS	286T	324TS	324T	326TS	326T	364TS	364T	365TS	365T
4x4x9B	4	C	13	14	16	18	21	23	22	24	24	25	25	26	26	27	29	28	28	30
		BASE	2	2	3	3	3	3	3	3	3	4								
		HY	8	8	8	8	8	8	8	8	8	8								
4x4x12	4	C	2	2	3	3	3	3	3	3	3	4								
		BASE	2	2	3	3	3	3	3	3	3	4								
		HY	8	8	8	8	8	8	8	8	8	8								
4x4x12	5	C			4	4	5	5	5	6	6	6	8	8	8	9				
		BASE			8	8	8	8	8	8	8	8	8	8	8	8				
		HY			8	8	8	8	8	8	8	8	8	8	8	8				
4x6x15	5	C			5	5	6	6	6	6	6	6	8	8	8	16	16	16	16	16
		BASE			8	8	8	8	8	8	8	8	8	8	8	8	8	8	8	8
		HY			8	8	8	8	8	8	8	8	8	8	8	8	8	8	8	8

CASE BORE DISCH.	POWER SERIES	MOTOR FRAME	404TS	404T	405TS	405T	444TS	444T
4x6x15	5	C	30	33	31	34	34	38
		BASE	16	16	16	16	16	17
		HY	8	8	8	8	8	8

NOTES:  
1. ALL DIMENSIONS IN INCHES.  
2. NOT FOR CONSTRUCTION PURPOSES UNLESS CERTIFIED.

# AURORA MODEL 651A PUMP

## FORMED STEEL BASE SPACER COUPLING

TABLE 2

CASE BORE SUCT. DISCH.	POWER SERIES	MOTOR FRAME	182T	184T	213T	215T	254T	256T	284TS	284T	286TS	286T	324TS	324T	326TS	326T	364TS	364T	365TS	365T
4x4x9B	4	C	13	14	16	18	21	23	22	24	24	25	25	26	26	27	29	28	30	30
4x4x12	4	BASE	2	2	3	3	4	4	4	4	4	4								
4x4x12	5	HY	8	8	8	8	8	8	8	8	8	8								
4x4x12	5	BASE	2	2	3	3	4	4	4	4	4	4								
4x4x12	5	HY	8	8	8	8	8	8	8	8	8	8								
4x6x15	5	BASE			5	5	6	6	6	6	6	6	9	9	9	9	17	17	17	17
4x6x15	5	HY			8	8	8	8	8	8	8	8	8	8	8	8	8	8	8	8

CASE BORE SUCT. DISCH.	POWER SERIES	MOTOR FRAME	404TS	404T	405TS	405T	444TS	444T
4x6x15	5	C	30	33	31	34	34	38
4x6x15	5	BASE	17	17	17	17	17	17
4x6x15	5	HY	8	8	8	8	8	8

NOTES:  
 1: DIMENSIONS IN INCHES.  
 2: ALL FOR CONSTRUCTION PURPOSES UNLESS CERTIFIED.

# AURORA MODEL 651A PUMP SPACER COUPLINGS

TABLE 3

CASE BORE SUCT. DISCH.	POWER SERIES	MOTOR FRAME		1B4T	213T	215T	254T	256T	284T	286T	324T	326T	364TS	364T	365TS	365T	404T	405TS	405T	444T	
		SIZE	HT																		
4x4x9B	4	1B2T	6	6	6	6	7	8	8												
			5	5	5	5	5	5	5												
4x4x12	4	1B2T	6	6	6	6	7	8	8												
			5	5	5	5	5	5	5												
4x4x12	5	1B2T					9	9	9	9	9	10									
								5	5	5	5	5									
4x6x15	5	1B2T					9	9	9	9	10	10	12	10	12	12	12	12	12	12	12
								7	7	7	7	7	7	7	7	7	7	7	7	7	7

NOTES:  
 1. ALL DIMENSIONS IN INCHES.  
 2. NOT FOR CONSTRUCTION PURPOSES UNLESS CERTIFIED.  
 3. SIZE: COUPLING SIZE FOR TYPE SC WOODS SURE-FLEX SPACER COUPLINGS.  
 4. HT: COUPLING GAP (DISTANCE BETWEEN SHAFTS)

# AURORA MODEL 651A PUMP

## DRIP RIM STEEL BASE STANDARD COUPLING

TABLE 4

DISCH. SUCT. CASING BOU OR RIM	POWER SERIES	MOTOR FRAME	184T	213T	215T	254T	256T	284TS	284T	286TS	286T	324TS	324T	326TS	326T	364TS	364T	365TS	365T
4x4x9B	4	C	13	14	16	18	21	23	24	24	25	25	26	26	27	28	28	28	30
4x4x12	4	BASE	9	9	9	10	10	10	10	10	10	10	10	10	10	10	10	10	10
4x4x12	5	HY	9	9	9	10	10	10	10	10	10	10	10	10	10	10	10	10	10
4x6x15	5	BASE	9	9	9	10	10	10	10	10	10	10	10	10	10	10	10	10	10
		HY	9	9	9	10	10	10	10	10	10	10	10	10	10	10	10	10	10
		BASE	9	9	9	10	10	10	10	10	10	10	10	10	10	10	10	10	10
		HY	9	9	9	10	10	10	10	10	10	10	10	10	10	10	10	10	10

DISCH. SUCT. CASING BOU OR RIM	POWER SERIES	MOTOR FRAME	404TS	404T	405TS	405T	444TS	444T
4x6x15	5	C	17	17	17	18	18	18
		BASE	17	17	17	18	18	18
		HY	17	17	17	18	18	18

NOTES:  
 1. DIMENSIONS IN INCHES.  
 2. NOT FOR CONSTRUCTION PURPOSES UNLESS CERTIFIED.

### SPACER COUPLING

TABLE 5

CASE BORE DISCH. SUCT.	POWER SERIES	MOTOR FRAME	184T	213T	215T	254T	256T	284TS	284T	286TS	286T	324TS	324T	326TS	326T	364TS	364T	365TS	365T
4x4x9B	4	C	13	14	16	18	10	10	10	13	13	22	24	24	23	22	24	24	24
		BASE	9	9	10	10	10	10	10	13	13	13	13	13	13	13	13	13	13
		HY	B	B	B	B	B	B	B	B	B	B	B	B	B	B	B	B	B
4x4x12	4	C	9	9	10	10	10	10	10	13	13	13	13	13	13	13	13	13	13
		BASE	9	9	10	10	10	10	10	13	13	13	13	13	13	13	13	13	13
		HY	B	B	B	B	B	B	B	B	B	B	B	B	B	B	B	B	B
4x4x12	5	C																	
		BASE																	
		HY																	
4x6x15	5	C																	
		BASE																	
		HY																	

CASE BORE DISCH. SUCT.	POWER SERIES	MOTOR FRAME	404TS	404T	405TS	405T	444TS	444T
4x6x15	5	C	30	33	31	34	34	38
		BASE	18	18	18	18	18	18
		HY	B	B	B	B	B	B

NOTES:  
 1. ALL DIMENSIONS IN INCHES.  
 2. NOT FOR CONSTRUCTION PURPOSES UNLESS CERTIFIED.

**THIS PAGE LEFT INTENTIONALLY BLANK**



# 3 x 3 x 7 SERIES 650A

ENCLOSED IMPELLER

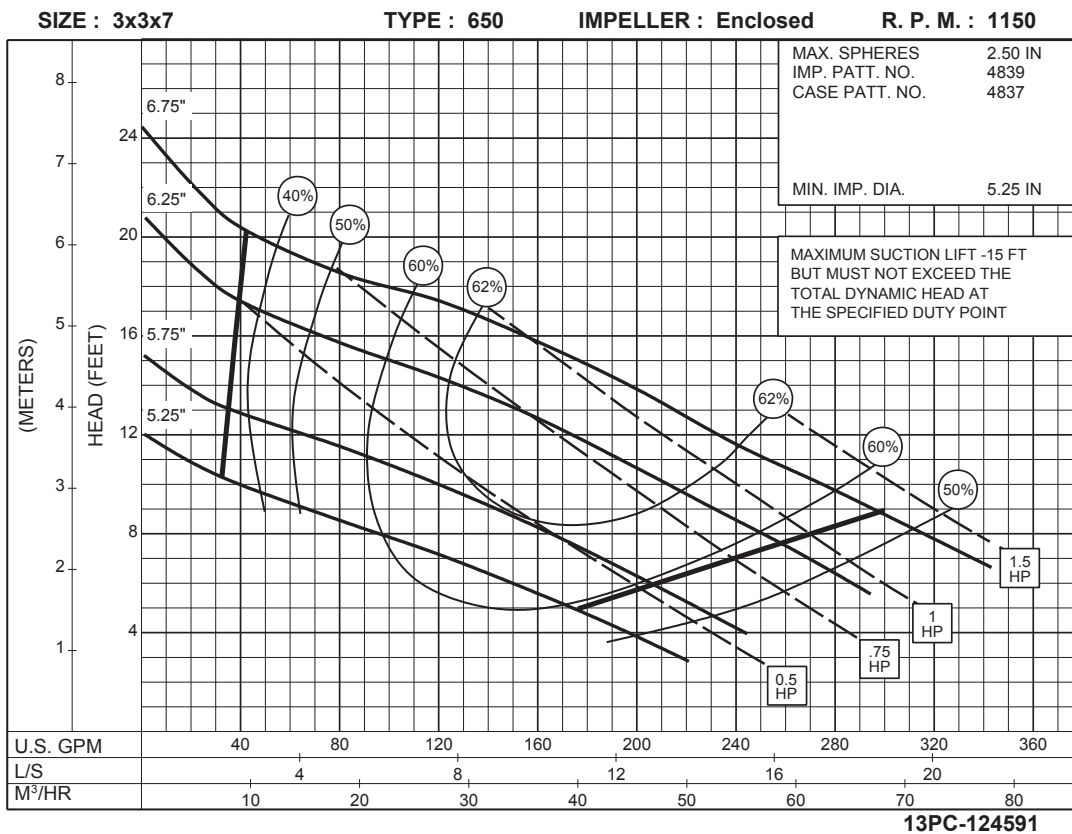
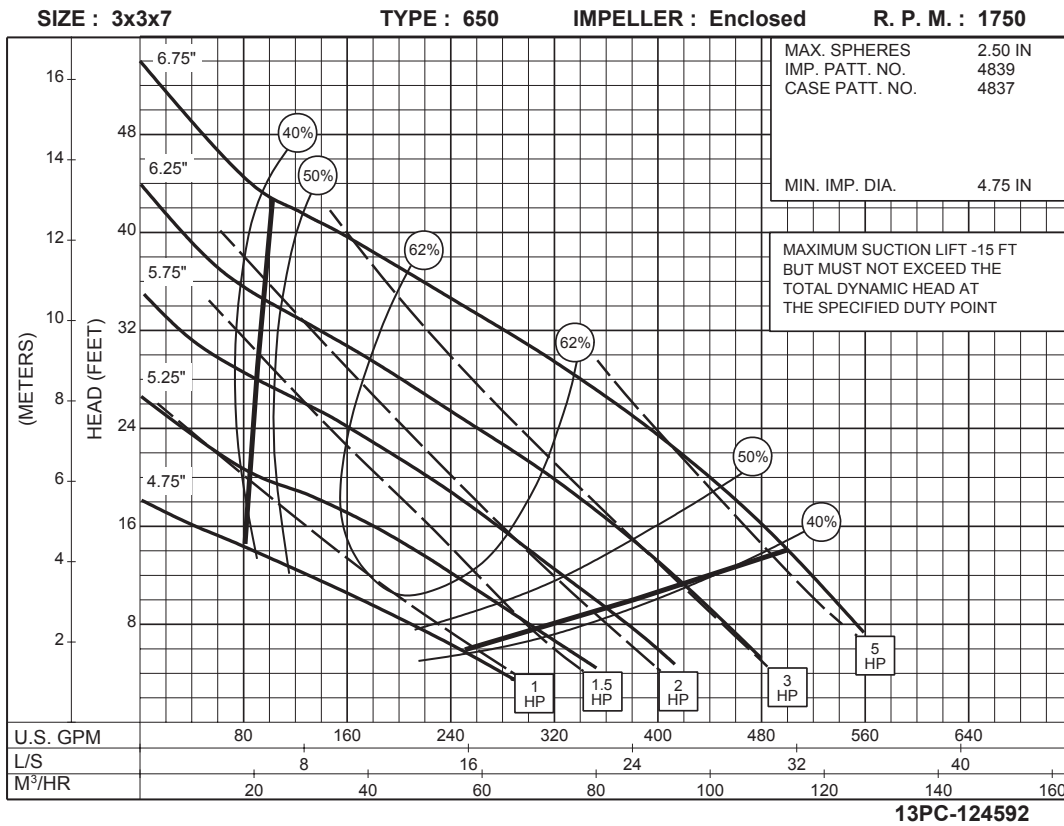

# 3 x 3 x 9 SERIES 650A

## ENCLOSED IMPELLER

SIZE : 3x3x9 TYPE : 650 IMPELLER : Enclosed R. P. M. : 1750

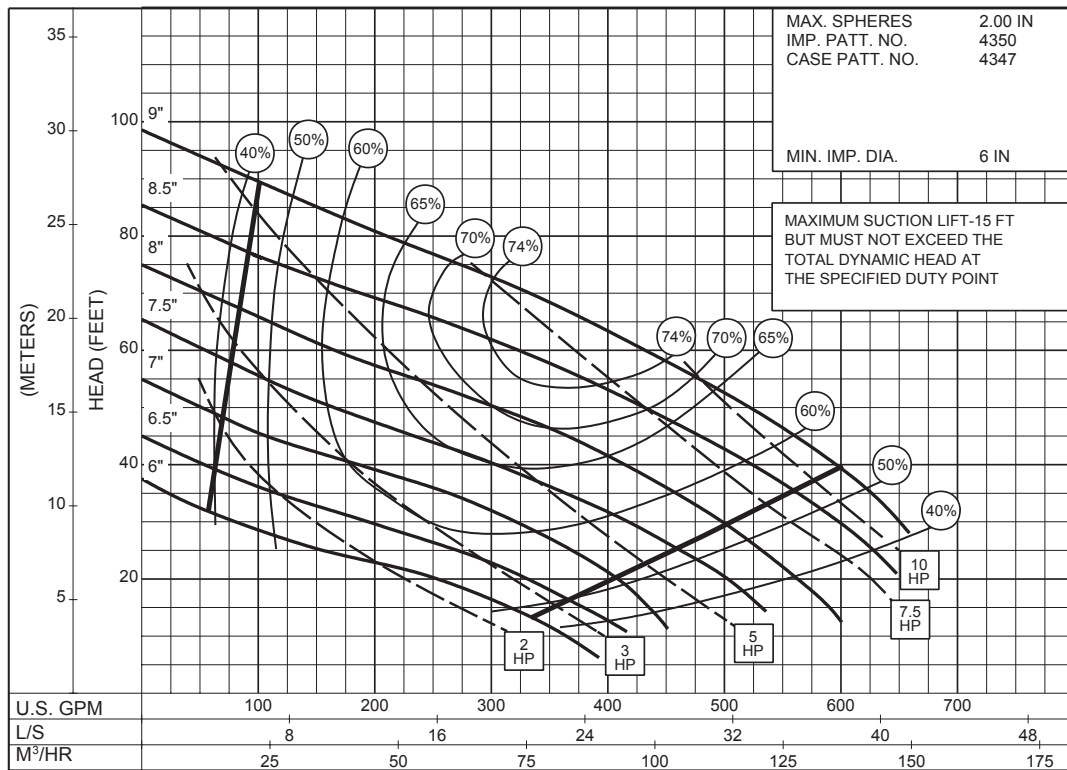

13PC-124590

**1750**  
RPM

SIZE : 3x3x9 TYPE : 650 IMPELLER : Enclosed R. P. M. : 1150

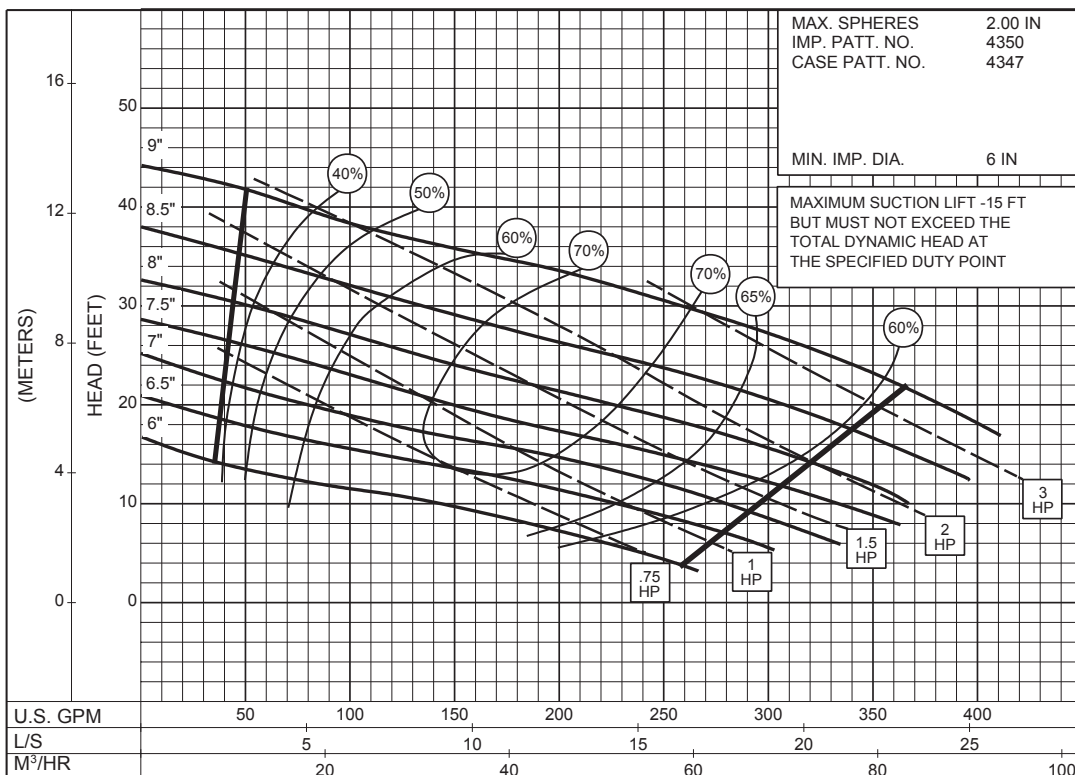

13PC-124589

**1150**  
RPM

# 4 x 4 x 7 SERIES 650A

## ENCLOSED IMPELLER

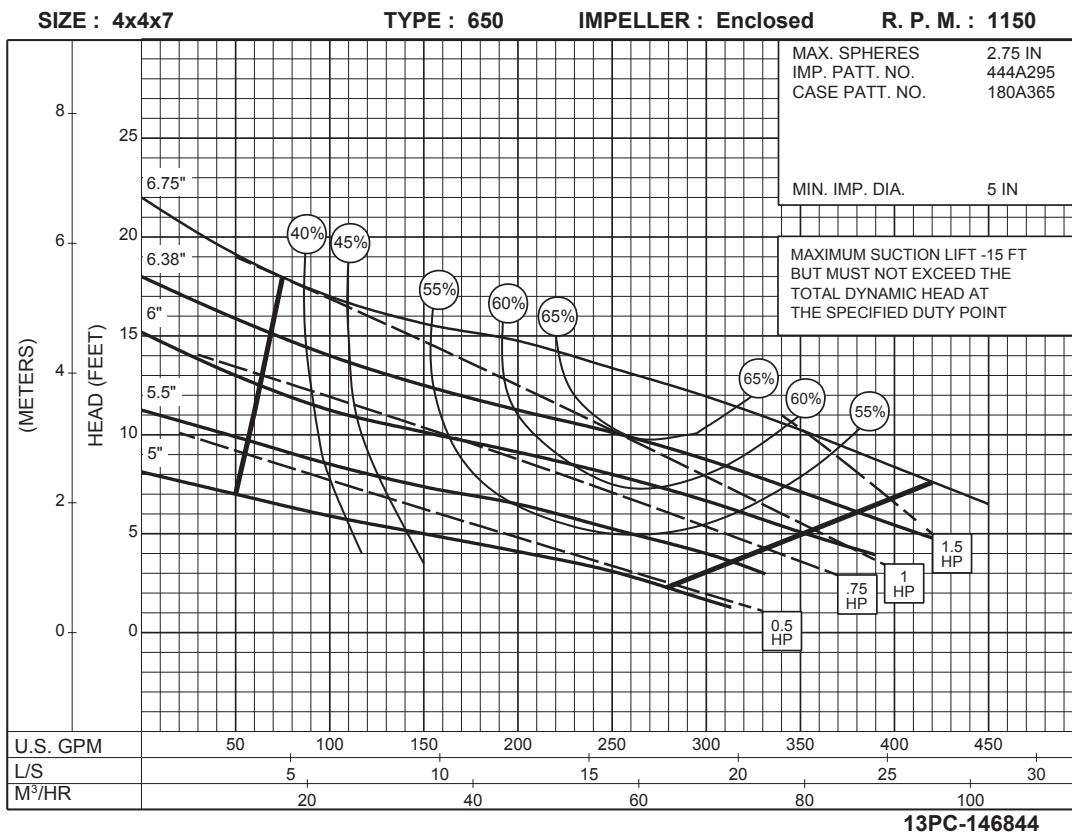
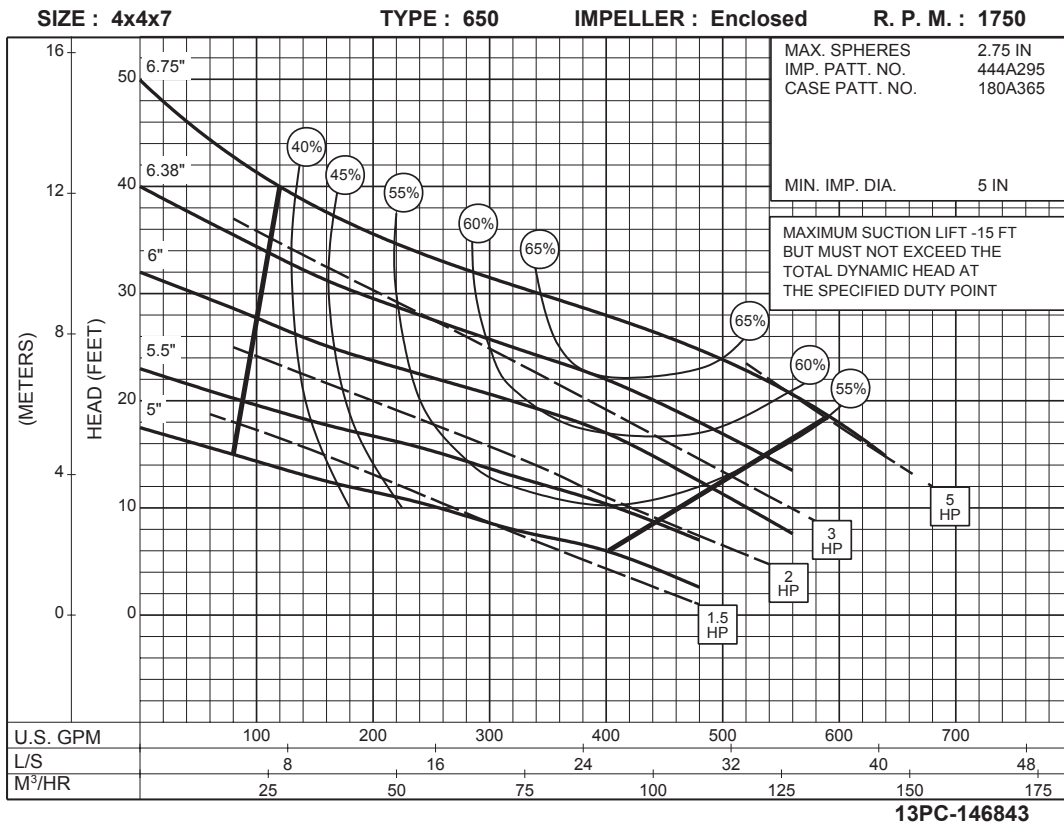

# 4 x 4 x 9A SERIES 650A

## ENCLOSED IMPELLER

SIZE : 4x4x9A      TYPE : 650      IMPELLER : Enclosed      R. P. M. : 1750

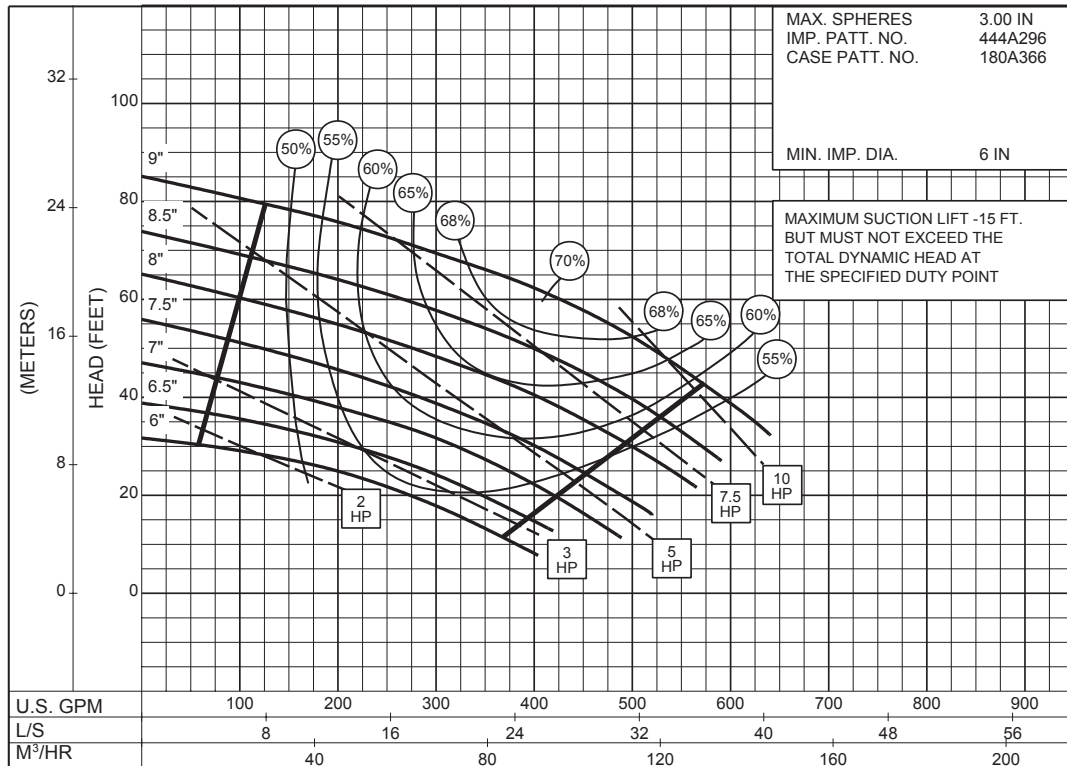

13PC-147001

**1750**  
RPM

SIZE : 4x4x9A      TYPE : 650      IMPELLER : Enclosed      R. P. M. : 1150

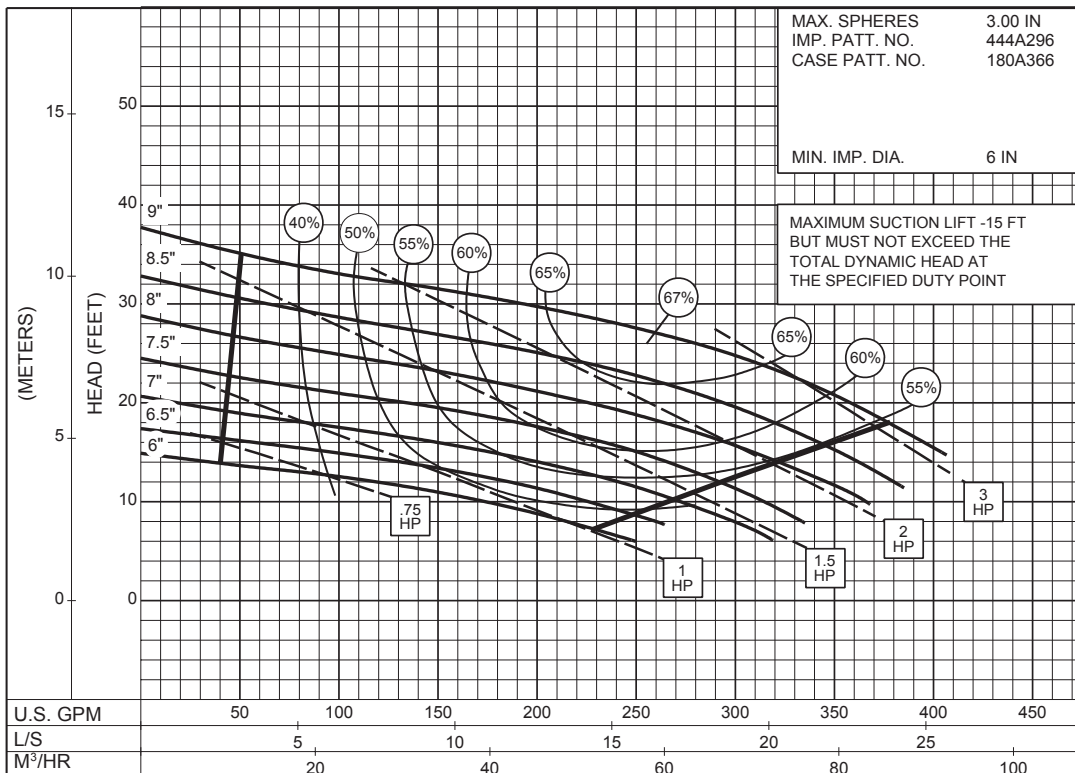

13PC-147002

**1150**  
RPM

# 4 x 4 x 9B SERIES 650A

ENCLOSED IMPELLER

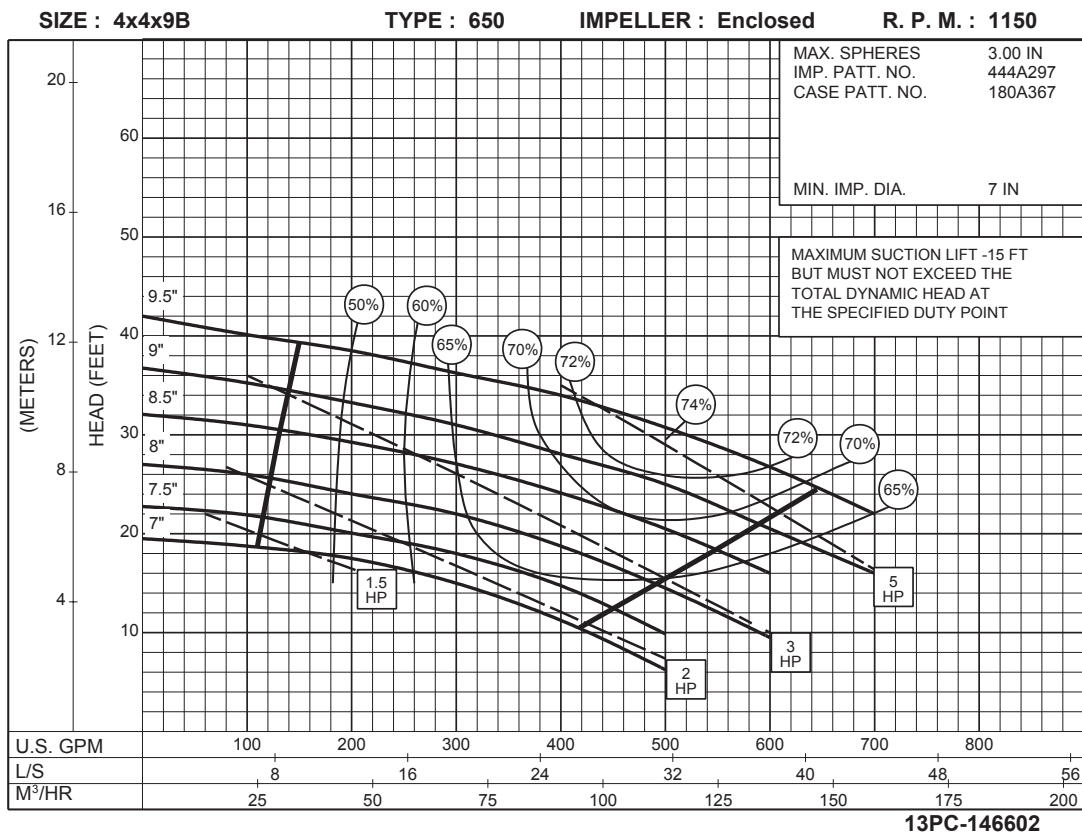
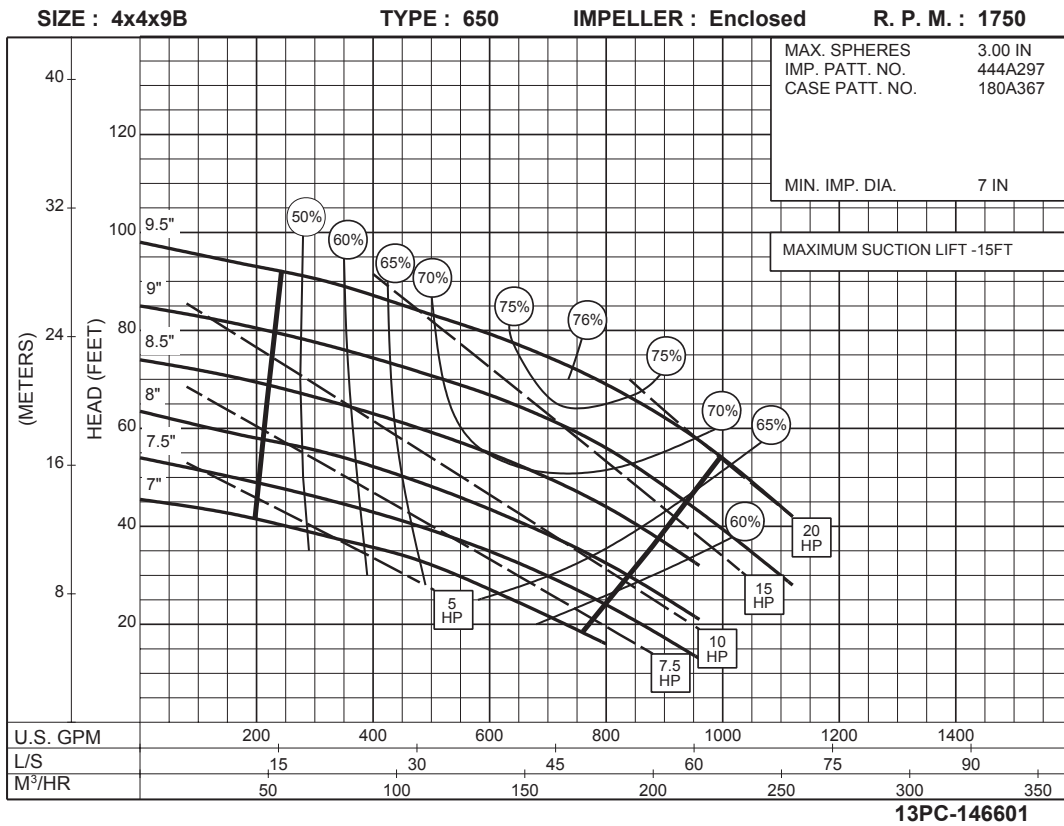

**4 x 4 x 9B**  
**SERIES 650A**

ENCLOSED IMPELLER

SIZE : 4x4x9B      TYPE : 650      IMPELLER : Enclosed      R. P. M. : 875

MAX. SPHERES      3.00 IN  
IMP. PATT. NO.      444A297  
CASE PATT. NO.      180A367

MIN. IMP. DIA.      7 IN

MAXIMUM SUCTION LIFT - 15 FT  
BUT MUST NOT EXCEED THE  
TOTAL DYNAMIC HEAD AT  
THE SPECIFIED DUTY POINT

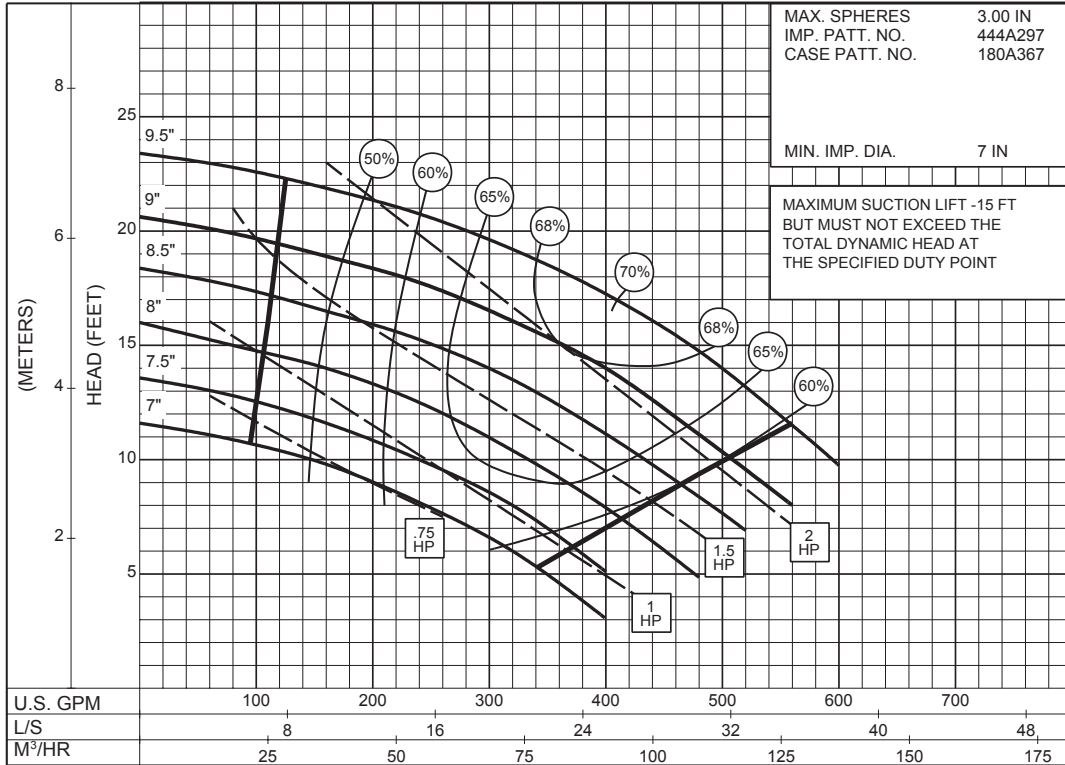

13PC-146603



# 4 x 4 x 12 SERIES 650A

ENCLOSED IMPELLER

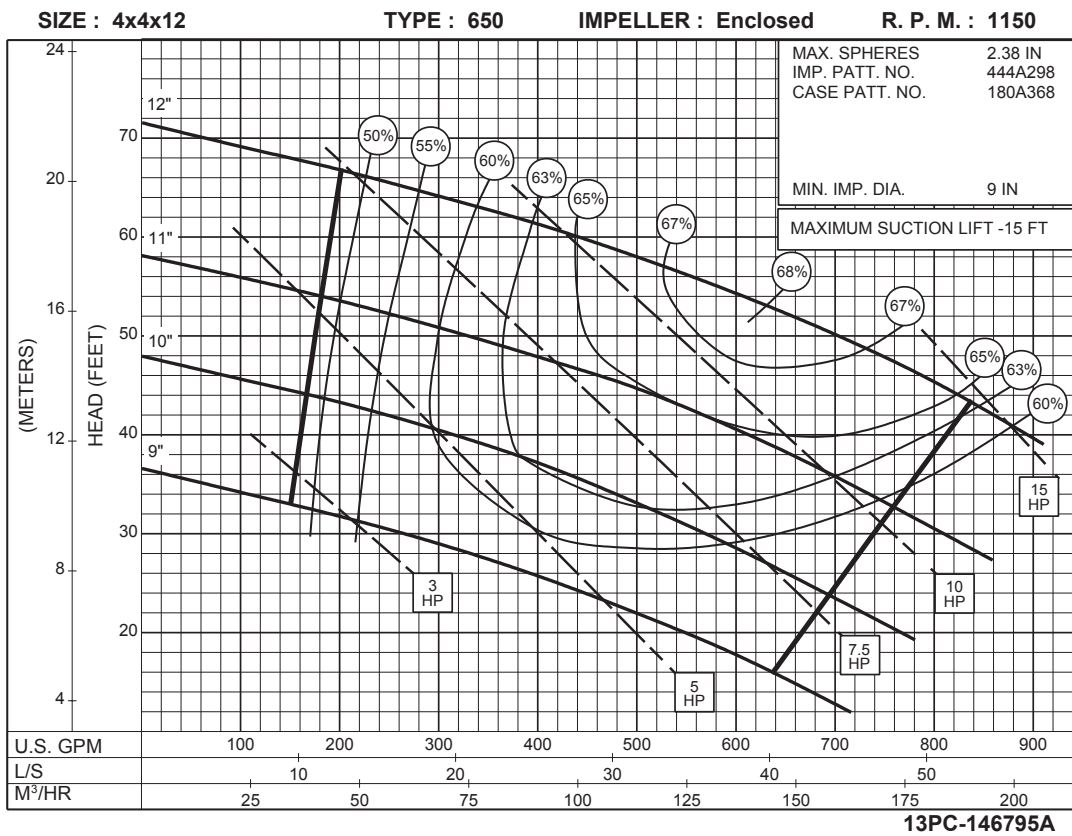
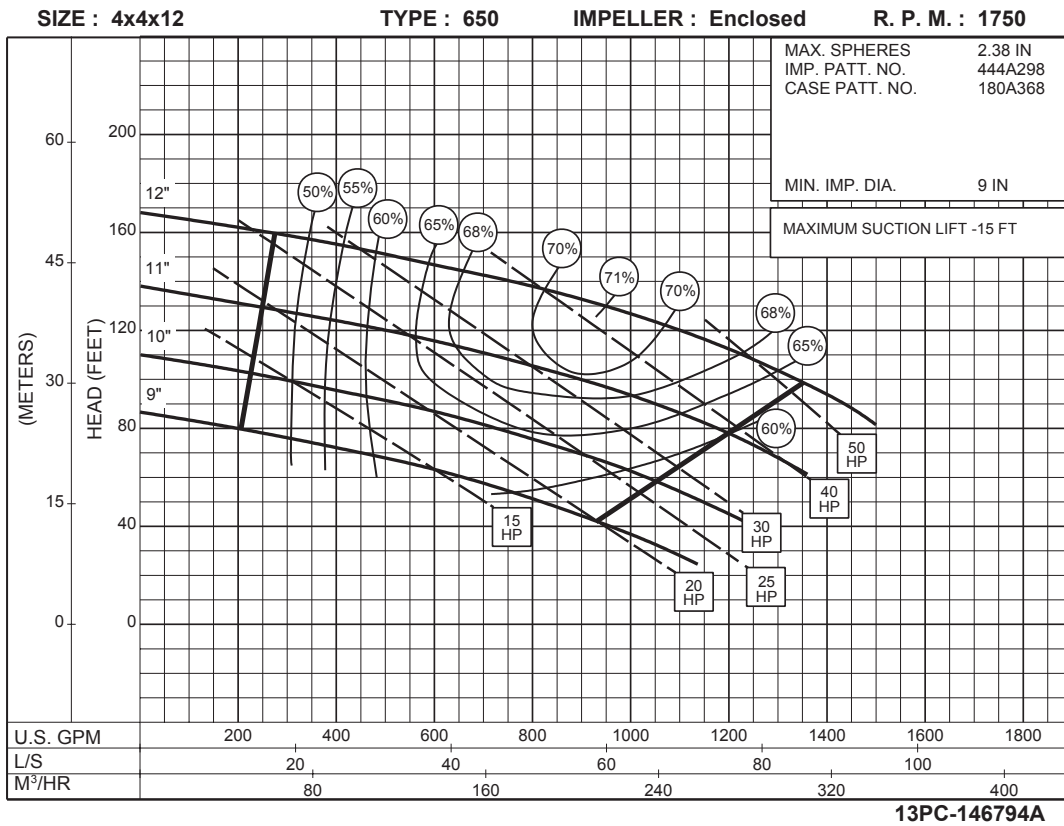

# 4 x 4 x 12 SERIES 650A

## ENCLOSED IMPELLER

SIZE : 4x4x12      TYPE : 650      IMPELLER : Enclosed      R. P. M. : 875

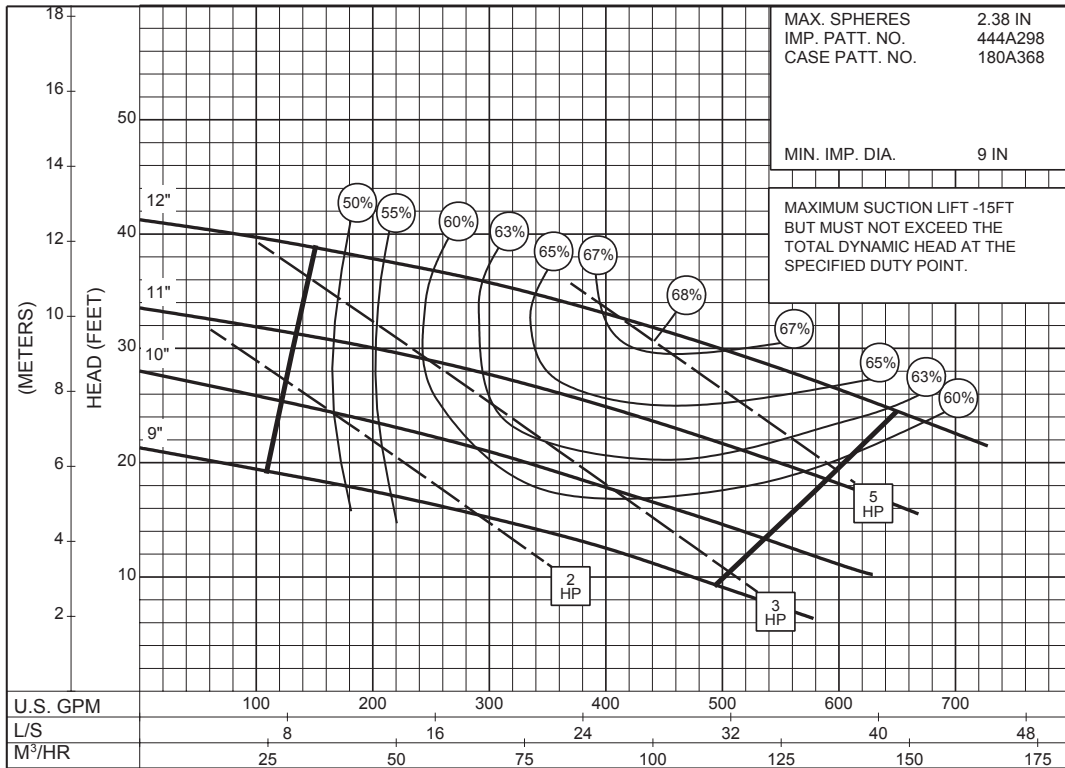

13PC-146796A

**875**  
RPM



# 4 x 6 x 15 SERIES 650A

ENCLOSED IMPELLER

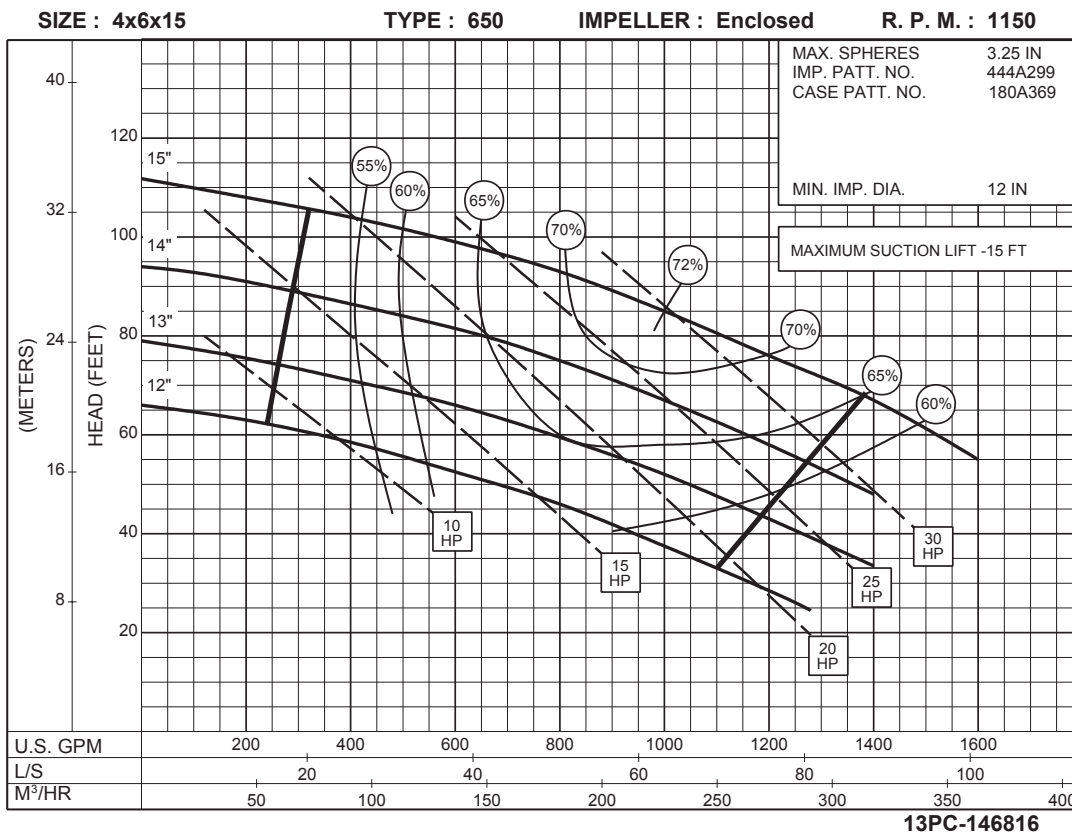
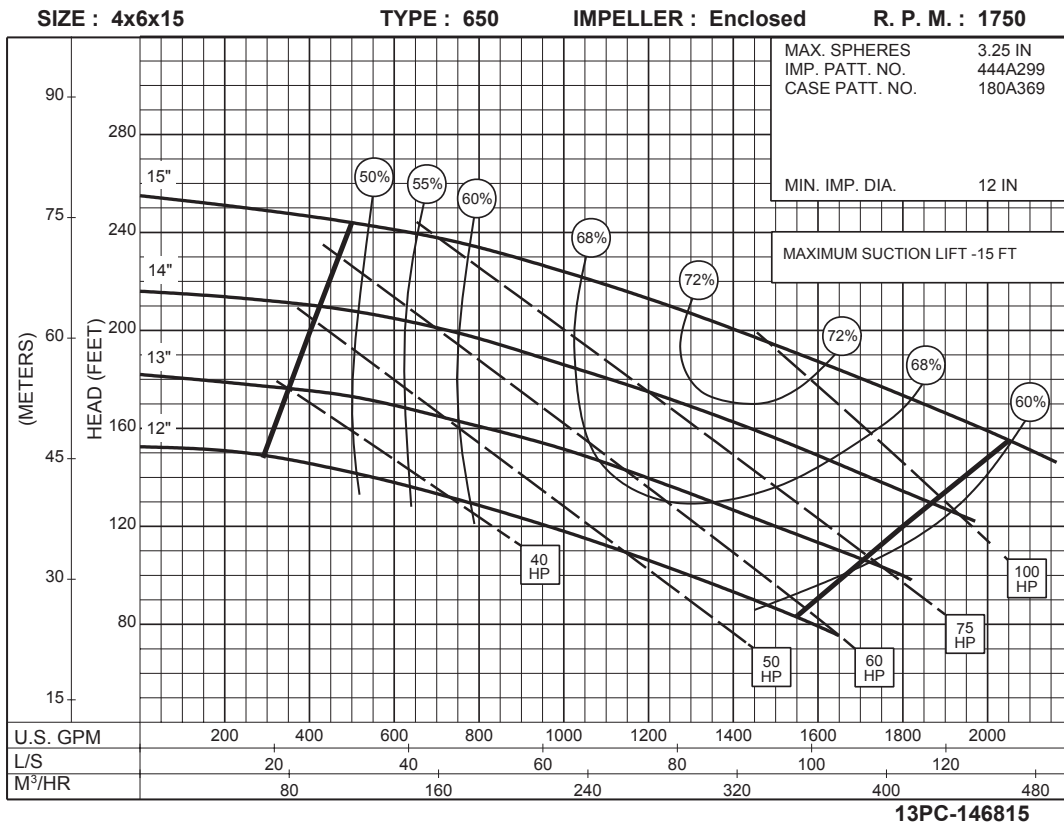

**4 x 6 x 15**  
**SERIES 650A**

ENCLOSED IMPELLER

**875**  
RPM

SIZE : 4x6x15 TYPE : 650 IMPELLER : Enclosed R. P. M. : 875

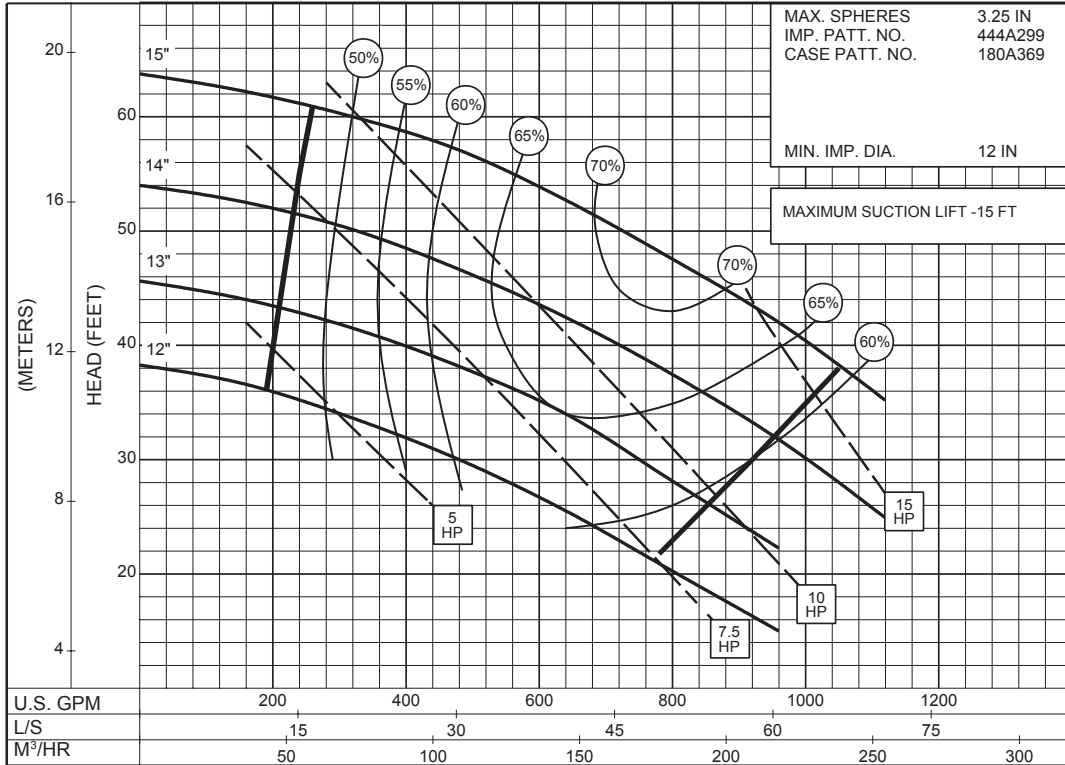

13PC-146817

**700**  
RPM

SIZE : 4x6x15 TYPE : 650 IMPELLER : Enclosed R. P. M. : 700

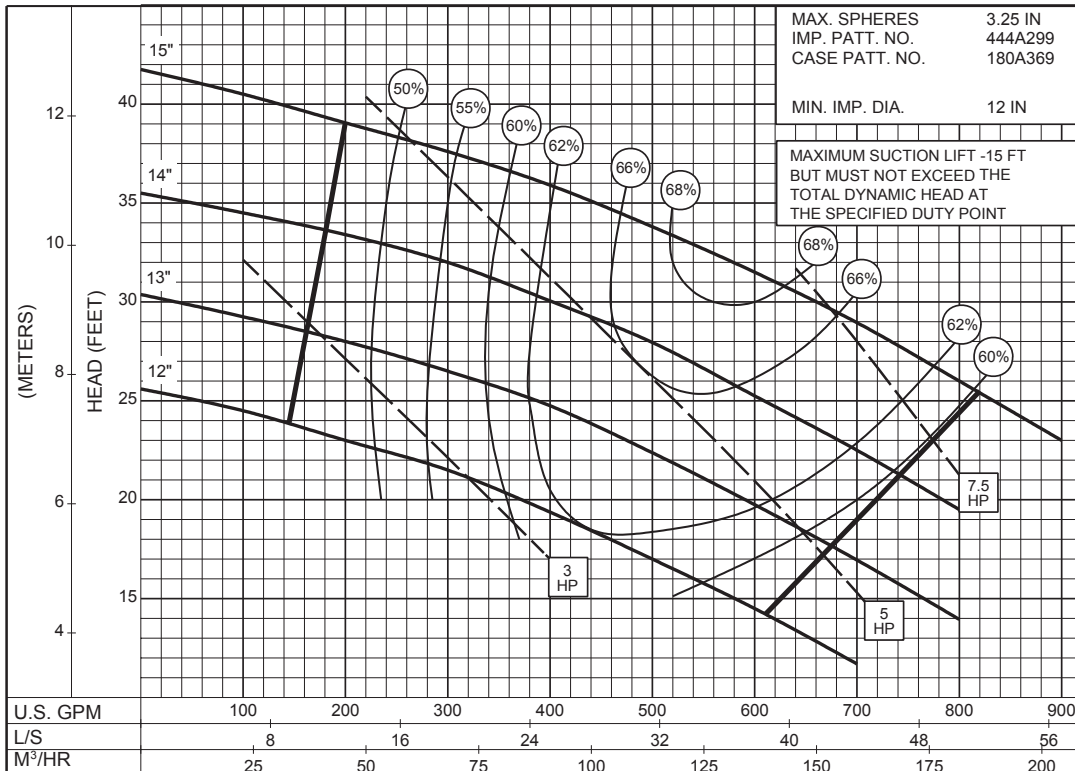

13PC-146818