

430 SERIES
ENGINEERING DATA
PIPE TAP CONNECTIONS
AND FUNCTION
POWER SERIES 2

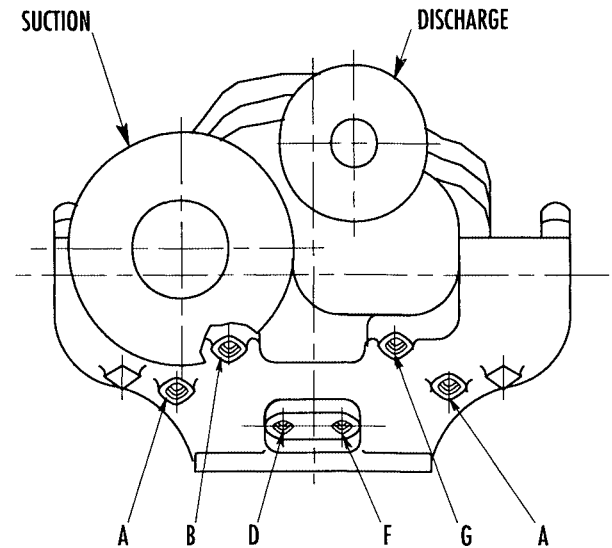
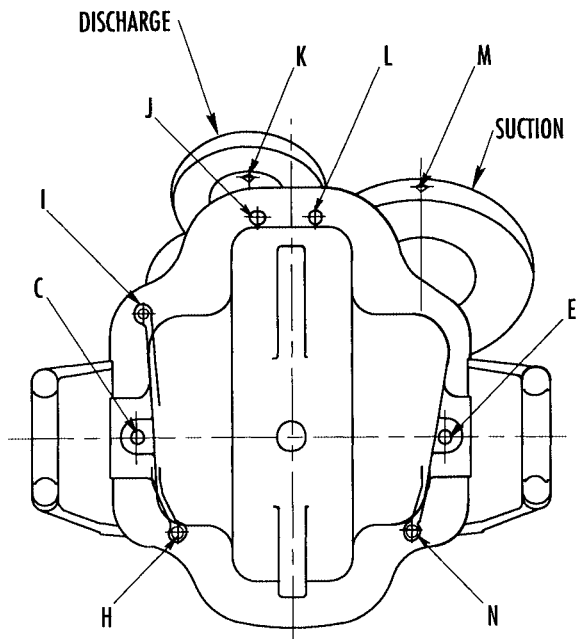

LETTER	PIPE TAP SIZE	DESCRIPTION
A	1/2	PACKING BOX DRAIN
B	1/2	FIRST STAGE SUCTION CHAMBER DRAIN
C	1/4	SECOND STAGE SEAL FLUSH
D	1/2	FIRST STAGE VOLUTE DRAIN
E	1/4	FIRST STAGE SEAL FLUSH
F	1/2	SECOND STAGE VOLUTE DRAIN
G	1/2	SECOND STAGE SUCTION CHAMBER DRAIN
H	1/4	INLET TO SECOND STAGE PACKING BOX
I	1/4	OUTLET FROM SECOND STAGE PACKING BOX
J	1/4	SECOND STAGE VOLUTE VENT (SEE NOTE 1)
K	1/4	DISCHARGE GAUGE CONNECTION
L	1/4	FIRST STAGE VOLUTE VENT (SEE NOTE 1)
M	1/4	SUCTION GAUGE CONNECTION
N	1/4	INLET TO FIRST STAGE PACKING BOX

NOTES:

1. CAUTION - LOOSEN VENT PLUGS "J" AND "L" AND ROTATE SHAFT SLOWLY TO VENT AIR.

AURORA MODEL 430 PUMPS

ENGINEERING DATA

EXTERNAL FLUSH LINE

SCHEMATICS / POWER SERIES 2

**MECHANICAL SEALS EXTERNAL FLUSH
STANDARD WITH INSIDE SEALS / OPTION 1**

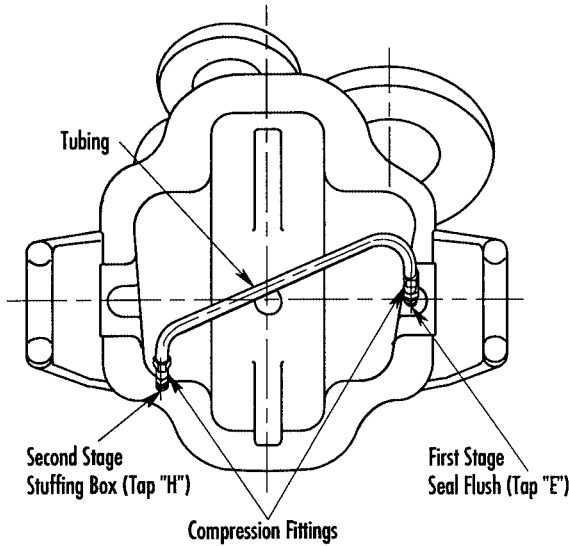

MECHANICAL SEALS EXTERNAL FLUSH / OPTION 16

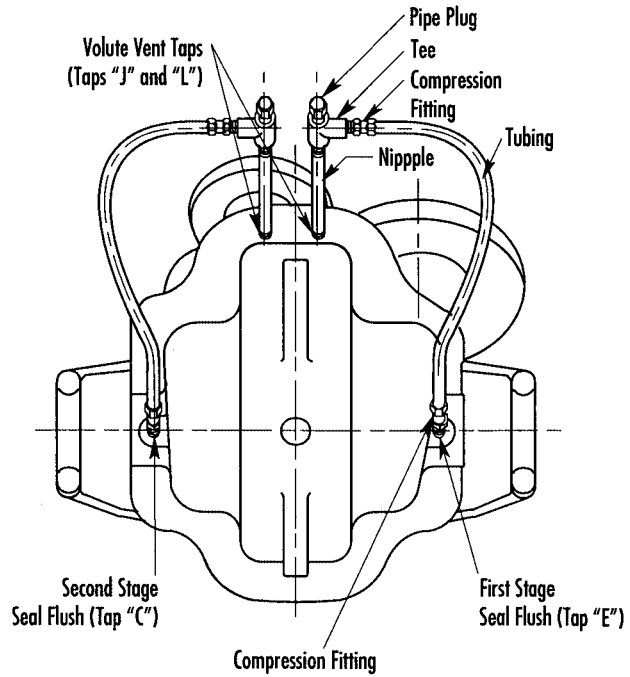

**PACKING WITH LANTERN RING - 1ST STAGE
EXTERNAL WATER SEAL / OPTION 37B**

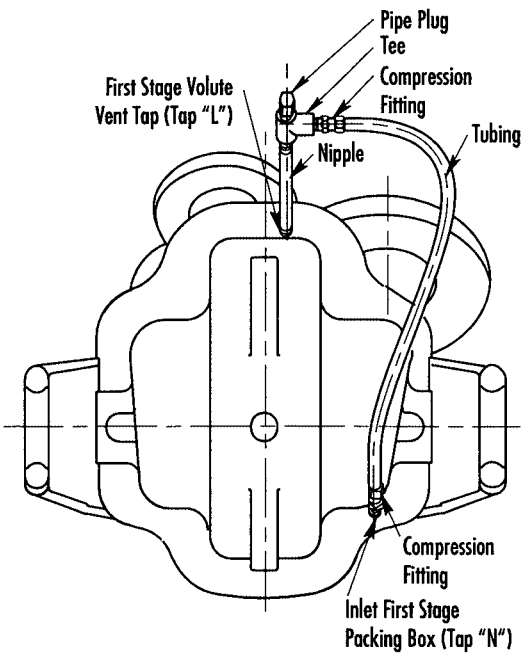

**PACKING WITH LANTERN RINGS - BOTH STAGES
EXTERNAL WATER SEAL / OPTION 37J**

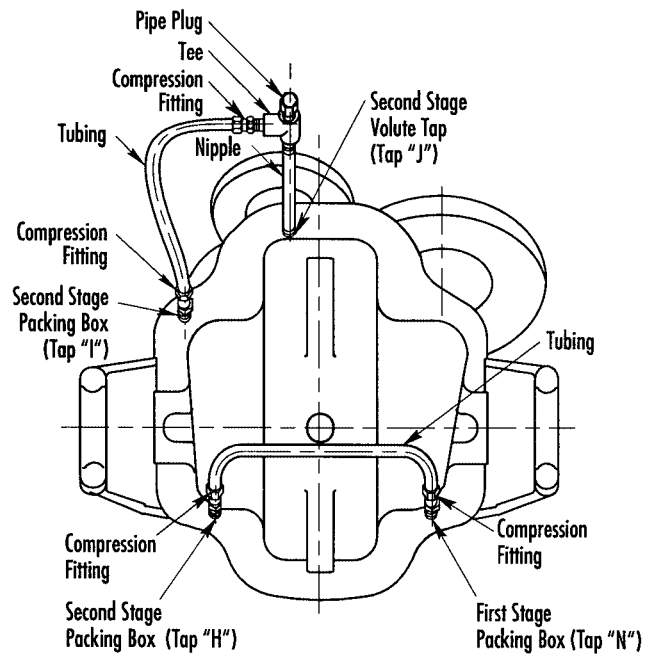

ENGINEERING DATA
PIPE TAP CONNECTIONS
AND FUNCTION
POWER SERIES 3A

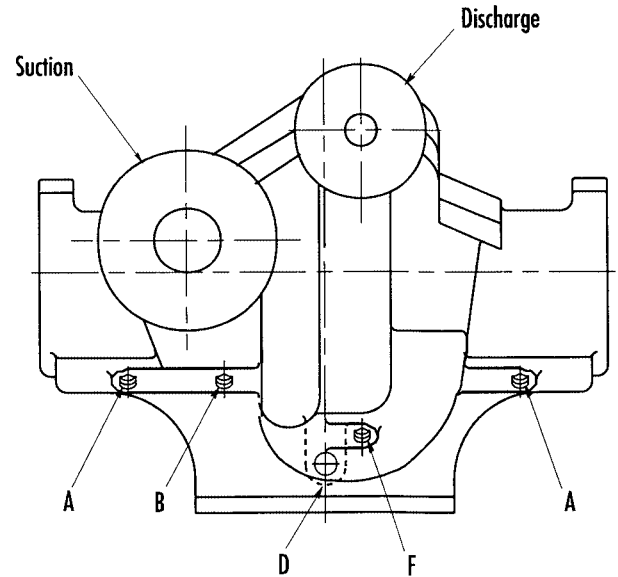
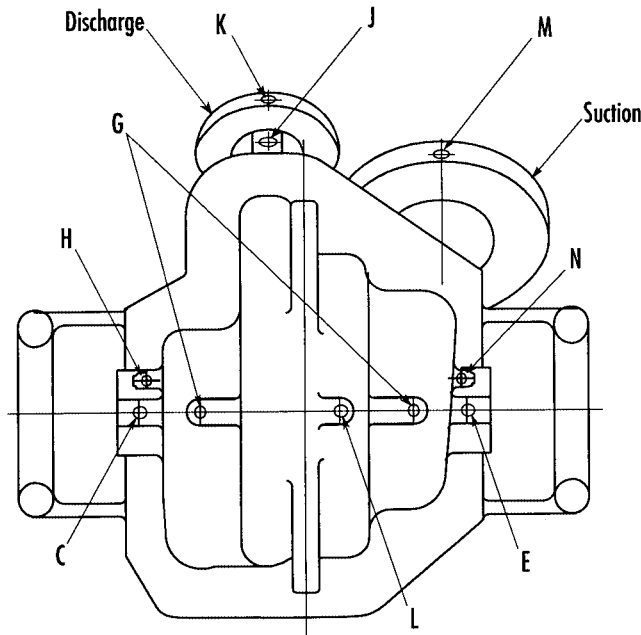

LETTER	PIPE TAP SIZE	DESCRIPTION
A	1/2	PACKING BOX DRAIN
B	1/2	FIRST STAGE SUCTION CHAMBER DRAIN
C	1/4	SECOND STAGE SEAL FLUSH
D	1	FIRST STAGE VOLUTE DRAIN & SECOND STAGE SUCTION DRAIN (1-1/2x3x11)
	1-1/4	FIRST STAGE VOLUTE DRAIN & SECOND STAGE SUCTION DRAIN (2x4x11)
E	1/4	FIRST STAGE SEAL FLUSH
F	1/2	SECOND STAGE VOLUTE DRAIN
G	1/4	SUCTION VENT
H	1/4	INLET TO SECOND STAGE PACKING BOX
J	1/4	SECOND STAGE VOLUTE VENT (SEE NOTE 1)
K	1/4	DISCHARGE GAUGE CONNECTION
L	1/4	FIRST STAGE VOLUTE VENT (SEE NOTE 1)
M	1/4	SUCTION GAUGE CONNECTION
N	1/4	INLET TO FIRST STAGE PACKING BOX

NOTES:
1. CAUTION - LOOSEN VENT PLUGS "J" AND "L" AND ROTATE SHAFT SLOWLY TO VENT AIR.

AURORA MODEL 430 PUMPS

ENGINEERING DATA EXTERNAL FLUSH LINE SCHEMATICS / POWER SERIES 3A

**MECHANICAL SEALS EXTERNAL FLUSH
 STANDARD WITH INSIDE SEALS / OPTION 1**

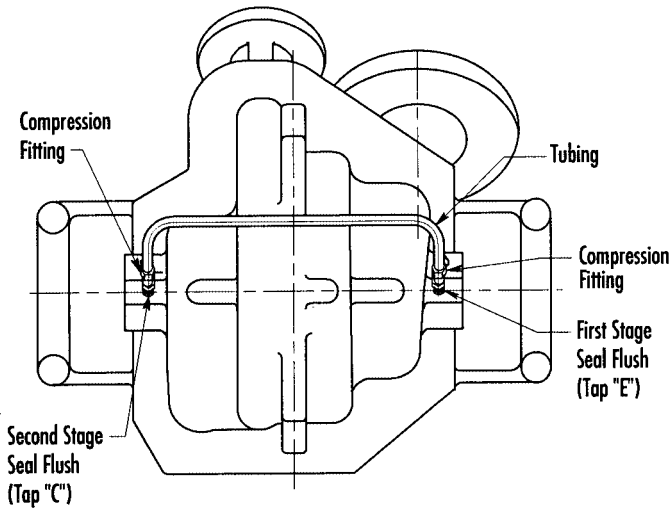

**MECHANICAL SEALS EXTERNAL FLUSH
 OPTION 16**

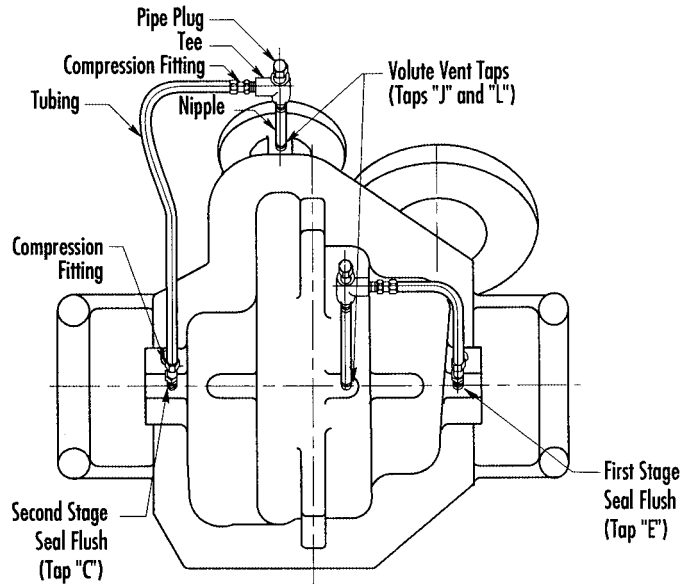

**PACKING WITH LANTERN RING – 1ST STAGE
 EXTERNAL WATER SEAL / OPTION 37B**

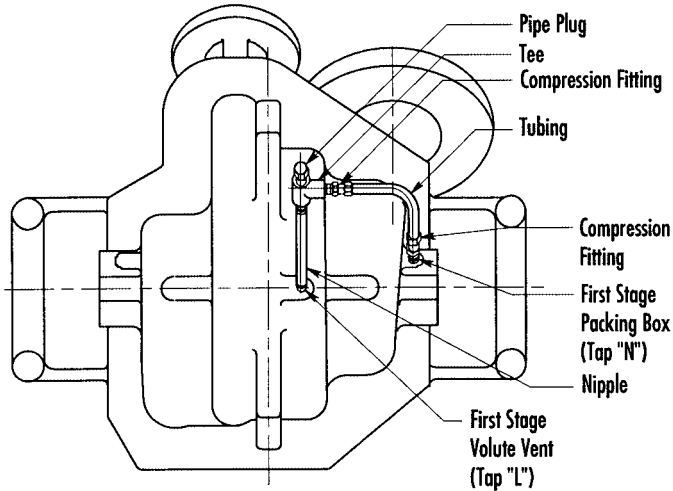

**PACKING WITH LANTERN RING – BOTH STAGES
 EXTERNAL WATER SEAL / OPTION 37J**

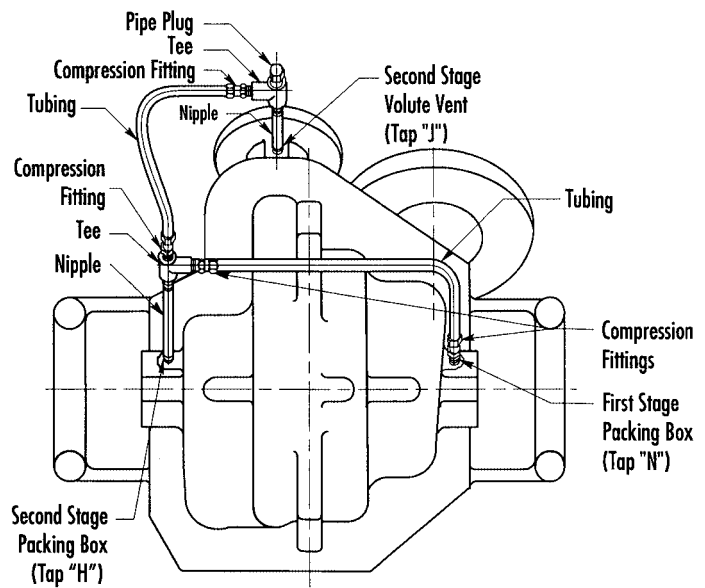

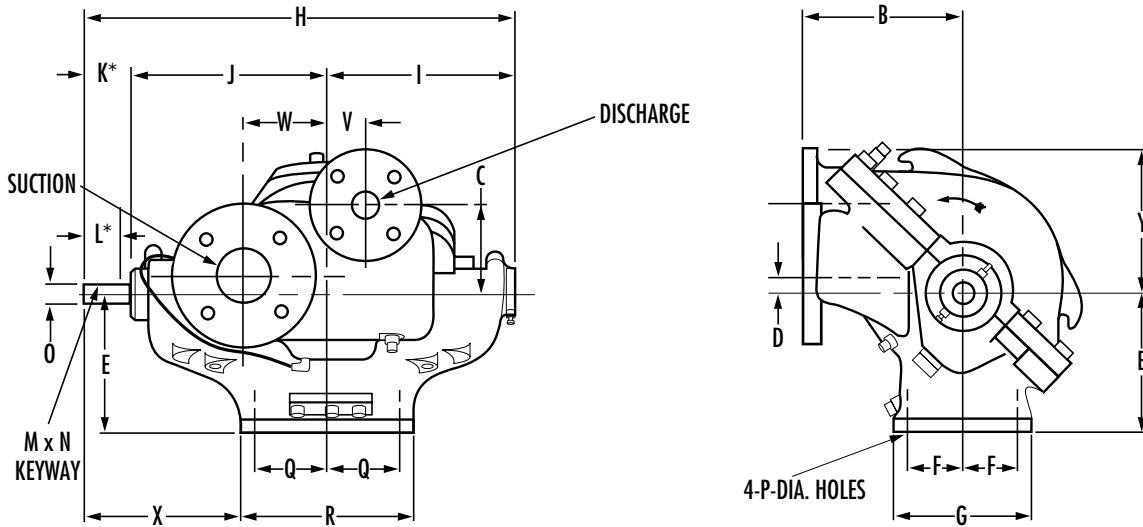

RIGHT HAND PUMPS

DISCH.	SUCT.	CASE BORE	B	C	D	E	F	G	H	I	J	K
1-1/2	3	9	9	5-1/4	1-1/2	8	3-1/2	8	26-1/4	11-3/4	11-3/4	2-3/4
2	4	9	9	5-1/4	1	8	3-1/2	8	26-1/4	11-3/4	11-3/4	2-3/4
1-1/2	3	11	11	6-1/2	1-1/2	11	4-3/8	10-1/2	34	14-7/8	14-7/8	4-1/4
2	4	11	11	6-9/16	1-1/2	11	4-3/8	10-1/2	34	14-7/8	14-7/8	4-1/4

DISCH.	SUCT.	CASE BORE	L	M	N	O	P	Q	R	V	W	X	Y
1-1/2	3	9	2-1/2	1/4	1/8	1-1/8	5/8	4	10	1-1/4	5-1/2	9-1/2	8-3/4
2	4	9	2-1/2	1/4	1/8	1-1/8	5/8	4	10	1-3/4	5-1/2	9-1/2	8-3/4
1-1/2	3	11	3	3/8	3/16	1-3/8	5/8	5	12	1-5/8	6-3/8	13-1/8	10
2	4	11	3	3/8	3/16	1-3/8	5/8	5	12	1-5/8	6-3/8	13-1/8	10

NOTES:

- All dimensions in inches.
- Dimensions may vary $\pm 3/8"$.
- Not for construction purposes unless certified.
- Discharge and suction flanges—American Standard flat face.

*L=Length of keyway

K=Length of shaft exposed

STD. 125# SUCTION FLANGES & 250# DISCHARGE FLANGES
OPT. 250# FLANGES

Section **430** Page **202** ■ **AURORA MODEL 431 PUMPS (LH)**

Dated **MAY 2001**

POWER SERIES NO. 2 AND 3A

Supersedes Section 430 Page 202

Dated FEBRUARY 1996

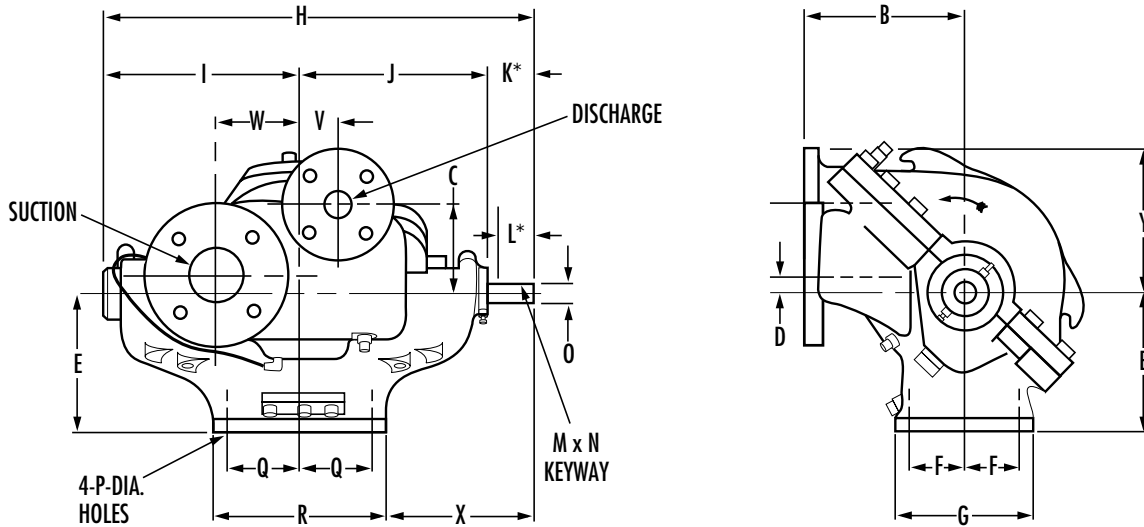

LEFT HAND PUMPS

DISCH.	SUCT.	CASE BORE	B	C	D	E	F	G	H	I	J	K
1-1/2	3	9	9	5-1/4	1-1/2	8	3-1/2	8	26-1/4	11-3/4	11-3/4	2-3/4
2	4	9	9	5-1/4	1	8	3-1/2	8	26-1/4	11-3/4	11-3/4	2-3/4
1-1/2	3	11	11	6-1/2	1-1/2	11	4-3/8	10-1/2	34	14-7/8	14-7/8	4-1/4
2	4	11	11	6-9/16	1-1/2	11	4-3/8	10-1/2	34	14-7/8	14-7/8	4-1/4

DISCH.	SUCT.	CASE BORE	L	M	N	O	P	Q	R	V	W	X	Y
1-1/2	3	9	2-1/2	1/4	1/8	1-1/8	5/8	4	10	1-1/4	5-1/2	9-1/2	8-3/4
2	4	9	2-1/2	1/4	1/8	1-1/8	5/8	4	10	1-3/4	5-1/2	9-1/2	8-3/4
1-1/2	3	11	3	3/8	3/16	1-3/8	5/8	5	12	1-5/8	6-3/8	13-1/8	10
2	4	11	3	3/8	3/16	1-3/8	5/8	5	12	1-5/8	6-3/8	13-1/8	10

NOTES:

1. All dimensions in inches.
2. Dimensions may vary $\pm 3/8"$.
3. Not for construction purposes unless certified.
4. Discharge and suction flanges—American Standard flat face.

*L=Length of keyway
K=Length of shaft exposed

<input type="checkbox"/>	STD. 125# SUCTION FLANGES & 250# DISCHARGE FLANGES
<input type="checkbox"/>	OPT. 250# FLANGES

AURORA MODEL 431 PUMPS (LH)

ON STEEL BASE

POWER SERIES NO. 2 AND 3A

STD. 125# SUCTION FLANGES & 250# DISCHARGE FLANGES
OPT. 250# FLANGES

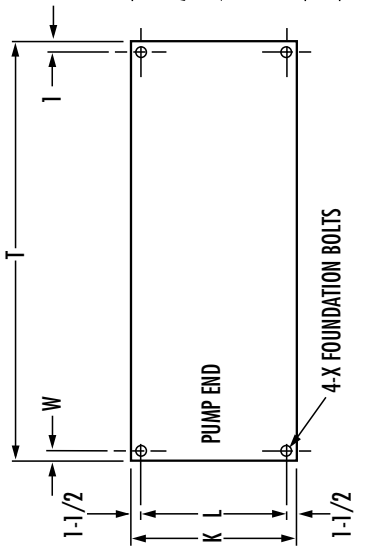
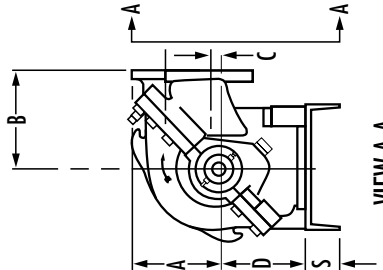
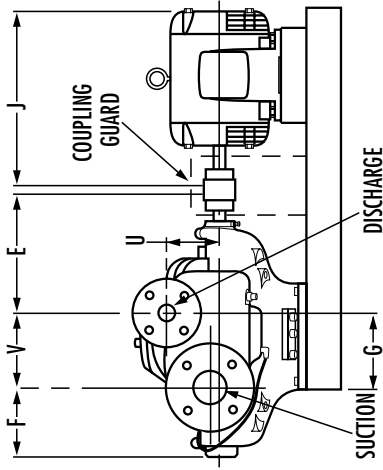

LEFT HAND PUMPS

NOTES:

1. All dimensions in inches.
2. Dimensions may vary $\pm 3/8"$.
3. Not for construction purposes unless certified.
4. Coupling gap may vary $1/8"$ to $1"$.
5. Discharge and suction flanges—American Standard flat face.
6. Conduit box is located on the opposite side of the motor shown. Dimensions are not specified as they vary with each motor manufacturer.

BASE	12x34	13x38	15x40	15x44	15x48	15x54	18x48	18x50	18x54	22x60
K	12	13	15	15	15	15	18	18	18	22
L	9	10	12	12	12	12	15	15	15	19
S	3	4	4	3-3/8	3-3/8	3-3/8	4	4	4	4
T	34	38	40	44	48	54	48	50	54	60
W	20	1	1	1	1	1	1	1	1	1
X	1/2	5/8	5/8	5/8	5/8	5/8	5/8	5/8	5/8	5/8

DISCH. SUCT.	CASE BORE	MOTOR FRAME															
		A	B	C	E	F	G	U	V	143T	145T	182T	184T	213T	215T	254T	256T
1-1/2	9	8-3/4	9	1-1/2	13-1/4	6-1/4	6-1/4	5-1/4	6-3/4	12x34	12x34	12x34	12x34	13x38	13x38	15x44	15x44
2	9	8-3/4	9	1	12-3/4	6-1/4	6-3/4	5-1/4	7-1/4	12x34	12x34	12x34	12x34	13x38	13x38	15x44	15x44
1-1/2	11	10	11	1-1/2	17-1/2	8-1/2	7-5/8	6-1/2	8	BASE	-	15x40	15x40	15x44	15x44	15x48	15x48
2	11	10	11	1-1/2	17-1/2	8-1/2	7-5/8	6-9/16	8	BASE	-	15x40	15x40	15x44	15x44	15x48	15x48

DISCH. SUCT.	CASE BORE	MOTOR FRAME															
		A	B	C	E	F	G	U	V	284TS	286TS	324TS	326TS	364TS	365TS	404TS	405TS
1-1/2	9	8-3/4	9	1-1/2	13-1/4	6-1/4	6-1/4	5-1/4	6-3/4	15x44	15x44	18x48	18x48	18x48	18x48	-	31
2	9	8-3/4	9	1	12-3/4	6-1/4	6-3/4	5-1/4	7-1/4	D	8	8	8	8	9	-	-
1-1/2	11	10	11	1-1/2	17-1/2	8-1/2	7-5/8	6-1/2	8	BASE	15x48	18x50	18x54	18x54	18x54	22x60	22x60
2	11	10	11	1-1/2	17-1/2	8-1/2	7-5/8	6-9/16	8	BASE	15x48	18x50	18x54	18x54	18x54	22x60	22x60

AURORA MODEL 431 PUMPS (RH)

ON STEEL DRIP RIM BASE

POWER SERIES NO. 2 AND 3A

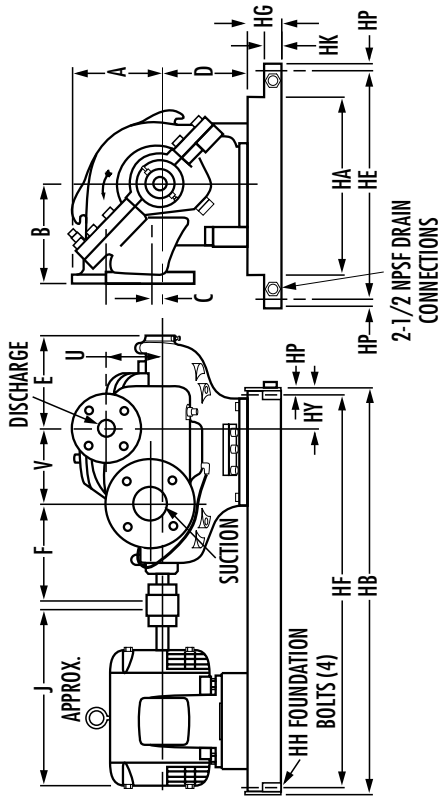

RIGHT HAND PUMPS

STD. 125# SUCTION FLANGES & 250# DISCHARGE FLANGES
OPT. 250# FLANGES

NOTES:

- All dimensions in inches.
- Dimensions may vary $\pm 3/8"$.
- Not for construction purposes unless certified.
- Coupling gap may vary $1/8"$ to $1"$.
- Discharge and suction flanges--American Standard flat face.
- Conduit box is located on the opposite side of the motor shown. Dimensions are not specified as they vary with each motor manufacturer.
- 3 grout holes are provided in top of base.

BASE	SIZE	HA	HB	HE	HF	HG	HH	HK	HP
3	9x33	9	33-1/2	13-3/4	32-1/4	3	3/8	1-1/2	5/8
5	11x36	11	36-1/2	15-7/8	35-1/8	3	1/2	1-1/2	11/16
6	11x42	11	42-1/2	15-7/8	41-1/8	3	1/2	1-1/2	11/16
8	14x42	14	42-1/2	19	41	3	5/8	1-1/2	3/4
9	14x48	14	48-1/2	19	47	3	5/8	1-1/2	3/4
11	18x46	18	46-1/2	25-1/8	44-7/8	4	3/4	2	13/16
12	18x54	18	54-1/2	25-1/8	52-7/8	4	3/4	2	13/16
15	22x54	22	54-1/2	29-1/8	52-7/8	4-1/2	3/4	2	13/16
16	22x64	22	64-1/2	29-1/8	62-7/8	4-1/2	3/4	2	13/16

DISCH. SUCT.	CASE BORE	A	B	C	E	F	HY	U	V	MOTOR FRAME									
										143T	145T	182T	184T	213T	215T	254T	256T		
1-1/2	9	8-3/4	9	1-1/2	10-1/2	9	4-1/4	5-1/4	6-3/4	J	12	13	13	14	16	18	21	23	
2	9	8-3/4	9	1	10	9	3-3/4	5-1/4	7-1/4	BASE	3	3	3	3	5	6	8	8	
1-1/2	11	10	11	1-1/2	13-1/2	12-3/4	4-7/8	6-1/2	8	D	8	8	8	8	8	8	8	8	
2	11	10	11	1-1/2	13-1/2	12-3/4	4-7/8	6-9/16	8	BASE	-	-	6	6	6	6	9	9	
										D	-	-	11	11	11	11	11	11	
										D	-	-	11	11	11	11	11	11	

DISCH. SUCT.	CASE BORE	A	B	C	E	F	HY	U	V	MOTOR FRAME									
										284TS	284T	286TS	324TS	326TS	364TS	365TS	404TS	405TS	
1-1/2	9	8-3/4	9	1-1/2	10-1/2	9	4-1/4	5-1/4	6-3/4	J	22	24	24	25	26	27	28	30	31
2	9	8-3/4	9	1	10	9	3-3/4	5-1/4	7-1/4	BASE	8	9	9	11	11	11	-	-	-
1-1/2	11	10	11	1-1/2	13-1/2	12-3/4	4-7/8	6-1/2	8	BASE	8	9	9	11	11	11	-	-	-
2	11	10	11	1-1/2	13-1/2	12-3/4	4-7/8	6-9/16	8	D	8	8	8	8	8	9	-	-	-
										BASE	9	9	9	12	12	12	12	15	16
										D	11	11	11	11	11	11	11	11	11
										BASE	9	9	9	12	12	12	12	15	16
										D	11	11	11	11	11	11	11	11	11

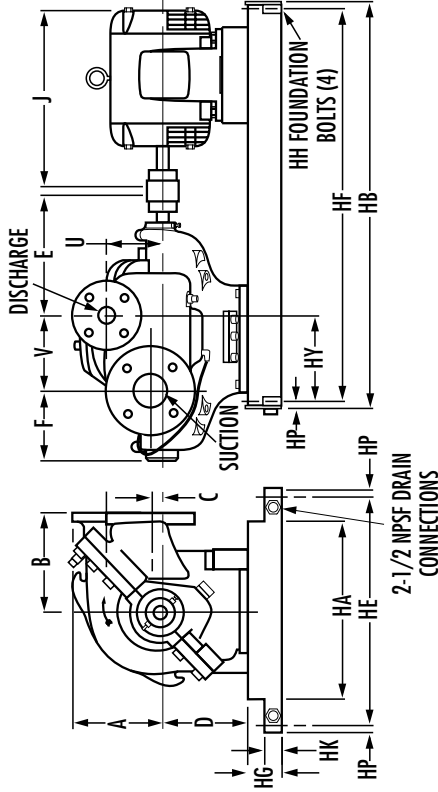

LEFT HAND PUMPS

STD. 125# SUCTION FLANGES & 250# DISCHARGE FLANGES
OPT. 250# FLANGES

NOTES:

- All dimensions in inches.
- Dimensions may vary $\pm 3/8"$.
- Not for construction purposes unless certified.
- Coupling gap may vary $1/8"$ to $1"$.
- Discharge and suction flanges—American Standard flat face.
- Conduit box is located on the opposite side of the motor shown. Dimensions are not specified as they vary with each motor manufacturer.
- 3 grout holes are provided in top of base.

BASE SIZE	HA	HB	HE	HF	HG	HH	HK	HP
3	9	33-1/2	13-3/4	32-1/4	3	3/8	1-1/2	5/8
5	11x36	11	36-1/2	35-1/8	3	1/2	1-1/2	11/16
6	11x42	11	42-1/2	41-1/8	3	1/2	1-1/2	11/16
8	14x42	14	42-1/2	41	3	5/8	1-1/2	3/4
9	14x48	14	48-1/2	47	3	5/8	1-1/2	3/4
11	18x46	18	46-1/2	44-7/8	4	3/4	2	13/16
12	18x54	18	54-1/2	52-7/8	4	3/4	2	13/16
15	22x54	22	54-1/2	52-7/8	4-1/2	3/4	2	13/16
16	22x64	22	64-1/2	62-7/8	4-1/2	3/4	2	13/16

DISCH. SUCT.	CASE BORE	A	B	C	E	F	HY	U	V	MOTOR FRAME									
										143T	145T	182T	184T	213T	215T	254T	256T		
1-1/2	9	8-3/4	9	1-1/2	13-1/4	6-1/4	5-3/4	5-1/4	6-3/4	J	12	13	13	14	16	18	21	23	
2	9	8-3/4	9	1	12-3/4	6-1/4	6-1/4	5-1/4	7-1/4	BASE	3	3	3	3	5	6	8	8	
1-1/2	11	10	11	1-1/2	17-1/2	8-1/2	7-1/8	6-1/2	8	D	8	8	8	8	8	8	8	8	
2	11	10	11	1-1/2	17-1/2	8-1/2	7-1/8	6-9/16	8	BASE	-	-	-	-	-	-	-	-	
										D	-	-	-	-	-	-	-	-	

DISCH. SUCT.	CASE BORE	A	B	C	E	F	HY	U	V	MOTOR FRAME									
										284TS	284T	286TS	324TS	326TS	364TS	365TS	404TS	405TS	
1-1/2	9	8-3/4	9	1-1/2	13-1/4	6-1/4	5-3/4	5-1/4	6-3/4	J	22	24	24	25	26	27	28	30	31
2	9	8-3/4	9	1	12-3/4	6-1/4	6-1/4	5-1/4	7-1/4	BASE	8	8	8	8	8	9	9	9	9
1-1/2	11	10	11	1-1/2	17-1/2	8-1/2	7-1/8	6-1/2	8	BASE	8	8	8	8	8	8	8	8	8
2	11	10	11	1-1/2	17-1/2	8-1/2	7-1/8	6-9/16	8	BASE	9	9	9	9	9	9	9	9	9
										D	11	11	11	11	11	11	11	11	11

1-1/2 x 3 x 9 SERIES 430

ENCLOSED IMPELLER

Section **430** Page **401**

Date **January 2001**

Supersedes Section 430 Page 401

Dated May 1995

SIZE : 1-1/2x3x9

TYPE : 430

IMPELLER : Enclosed

R. P. M. : 3500

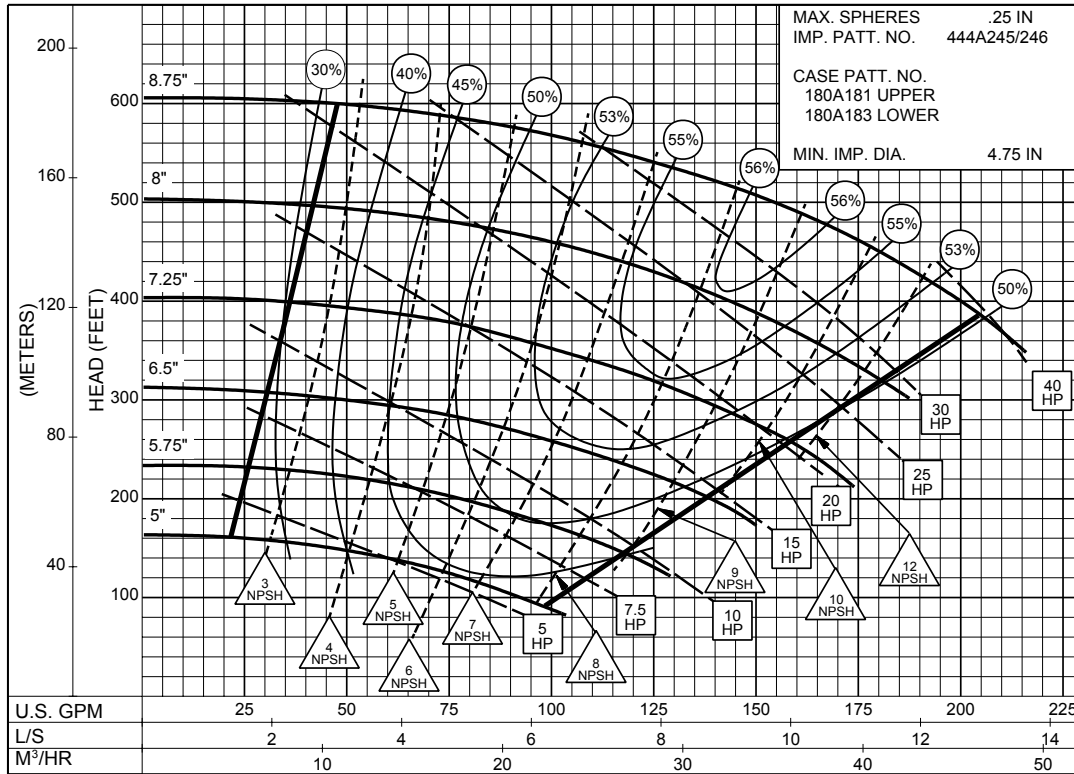

1PC-116118A

3500
R.P.M

SIZE : 1-1/2x3x9

TYPE : 430

IMPELLER : Enclosed

R. P. M. : 1750

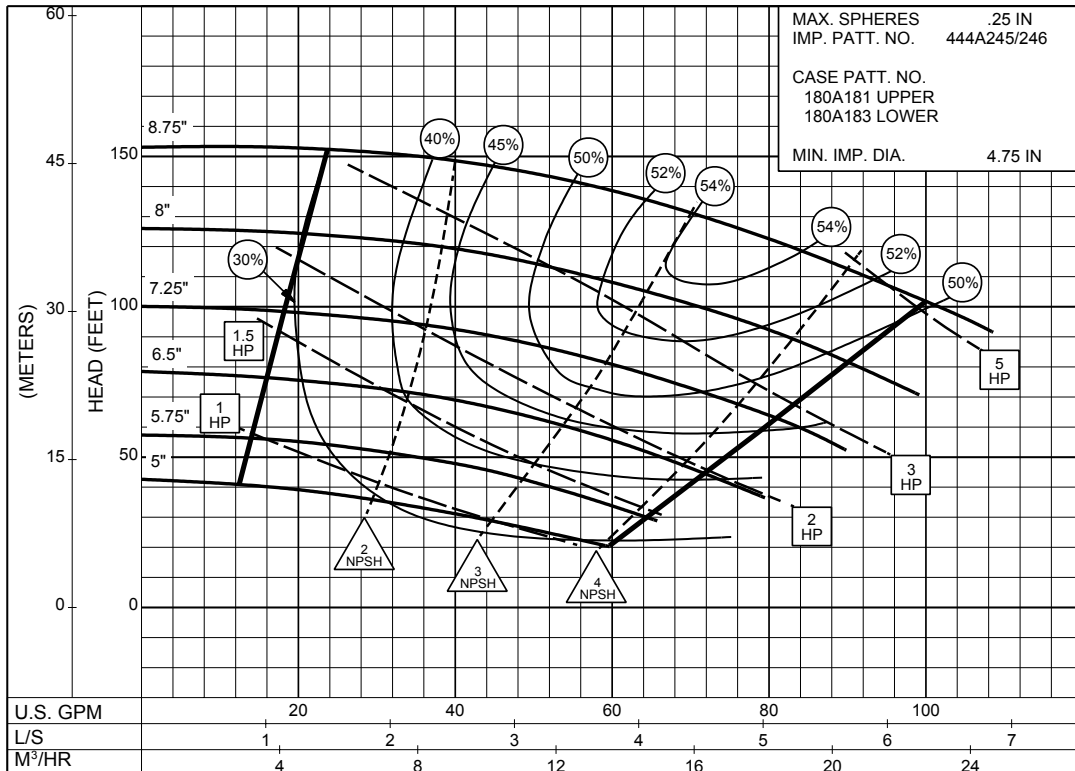

1PC-116119A

1750
R.P.M

ENCLOSED IMPELLER

Supersedes Section 430 Page 402
 Dated May 1995

SIZE : 1-1/2x3x11 TYPE : 431 IMPELLER : Enclosed R. P. M. : 3550

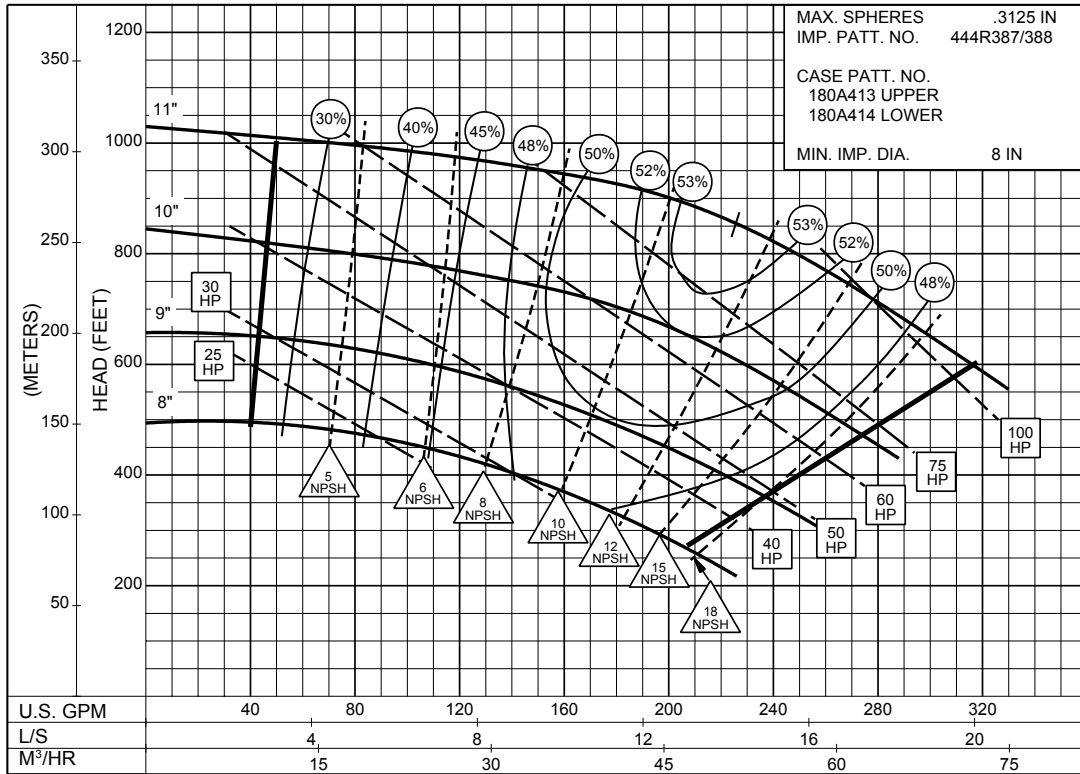

1PC-158883

3550
R.P.M

SIZE : 1-1/2x3x11 TYPE : 431 IMPELLER : Enclosed R. P. M. : 1750

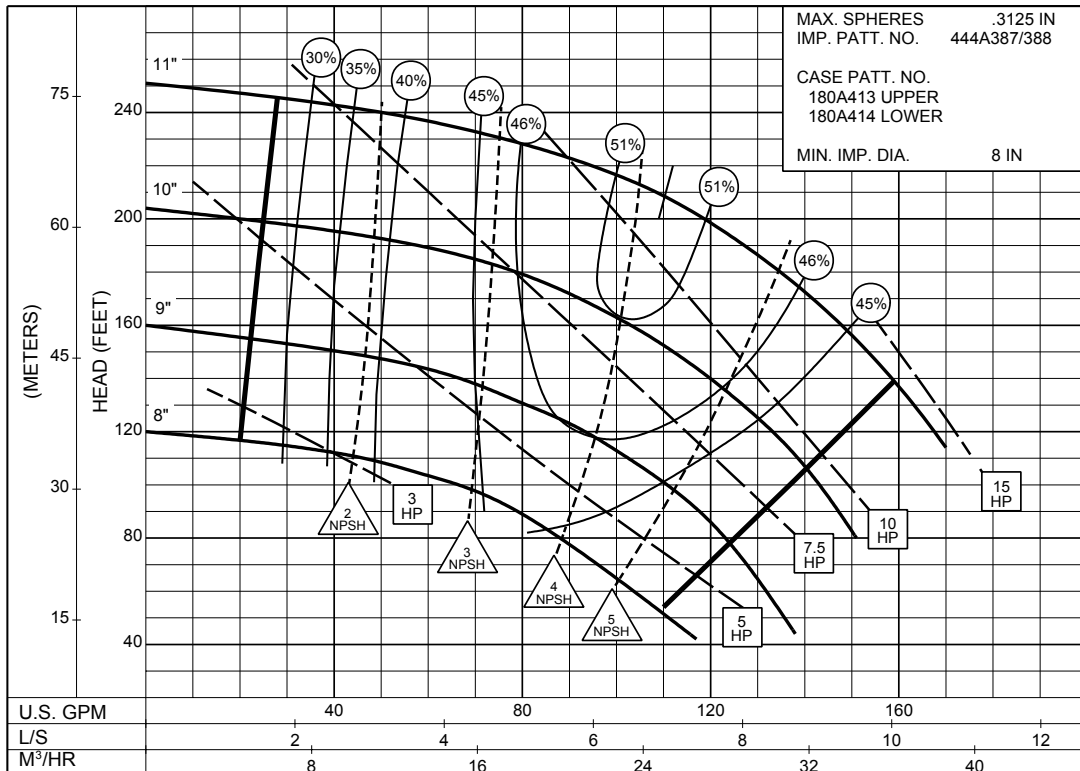

1PC-158908

1750
R.P.M

2 x 4 x 9 SERIES 430

ENCLOSED IMPELLER

SIZE : 2x4x9

TYPE : 430

IMPELLER : Enclosed

R. P. M. : 3500

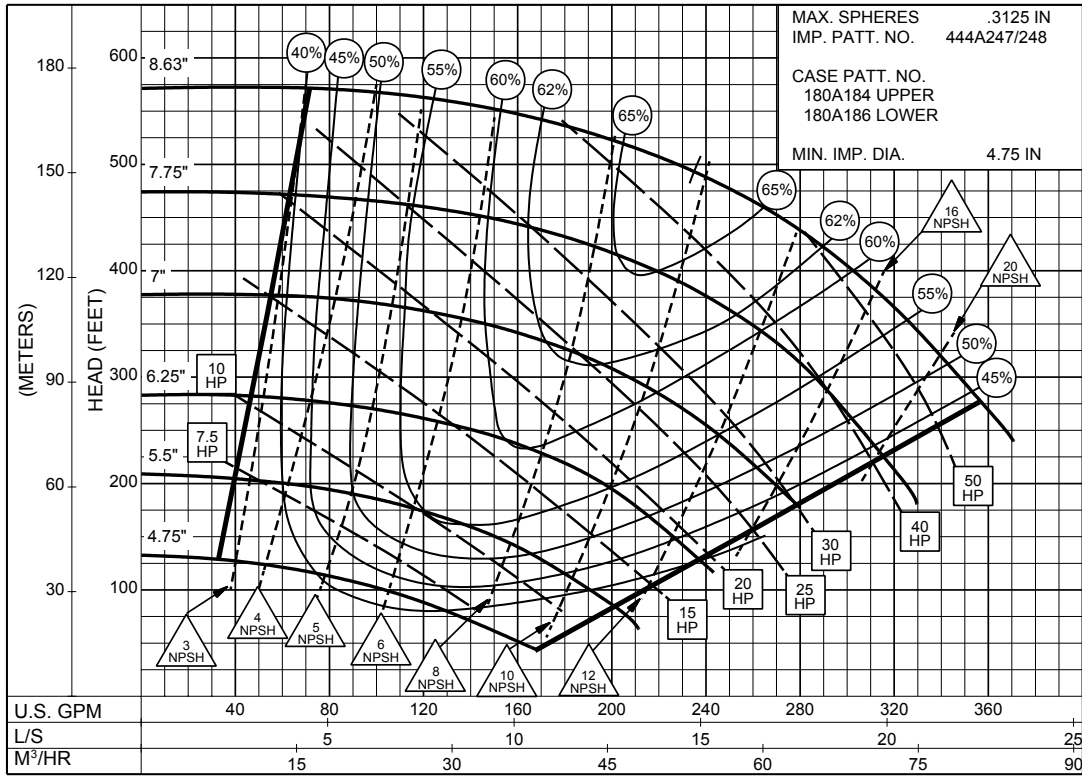

1PC-116120A

3500
R.P.M

SIZE : 2x4x9

TYPE : 430

IMPELLER : Enclosed

R. P. M. : 1750

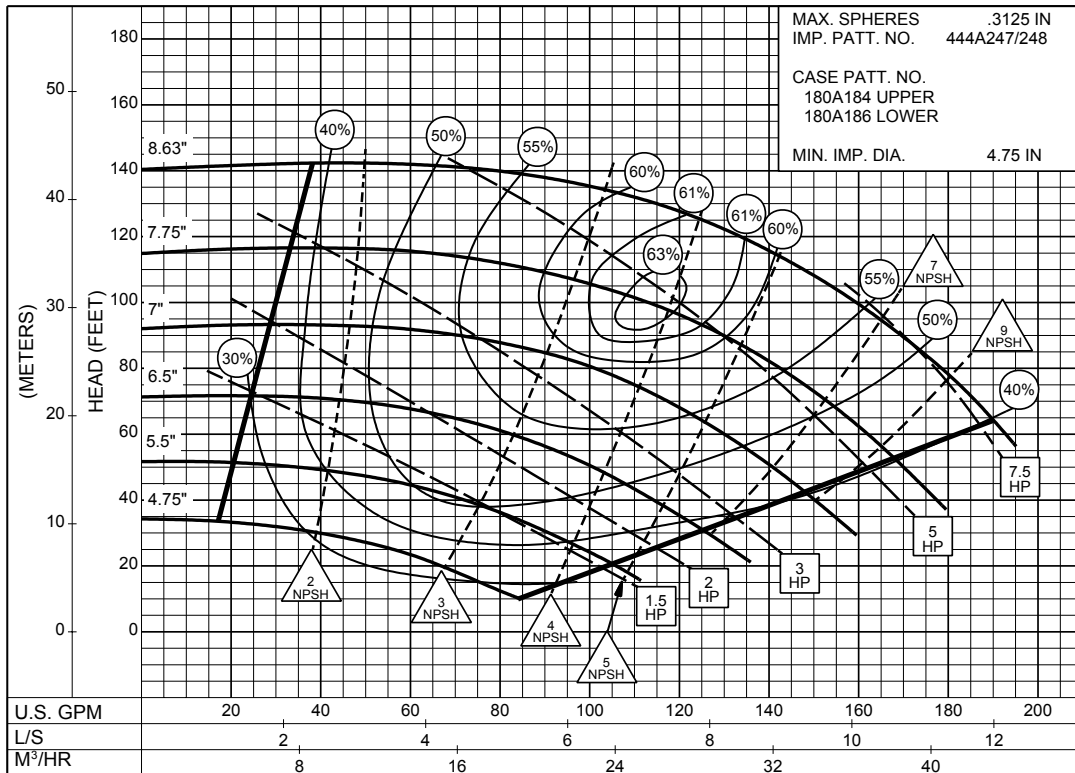

1PC-116121A

1750
R.P.M

2 x 4 x 11 SERIES 430

ENCLOSED IMPELLER

SIZE : 2x4x11

TYPE : 431

IMPELLER : ENCLOSED

R. P. M. : 3550

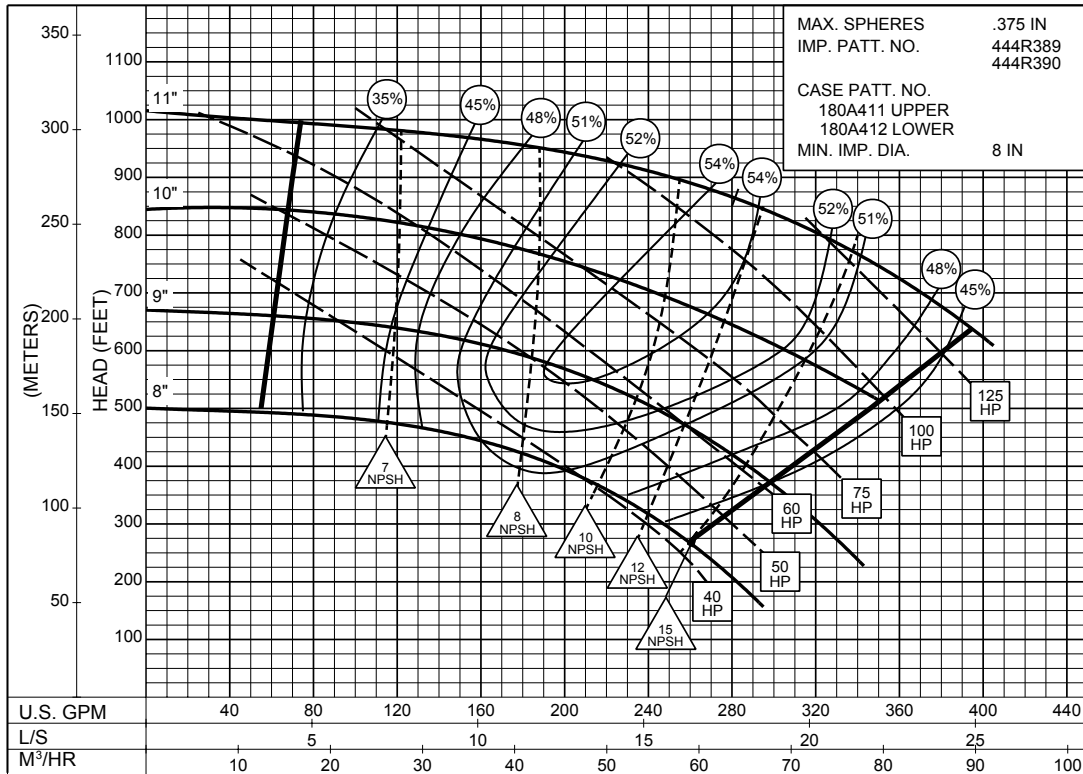

PC-158291

3550
R.P.M

SIZE : 2x4x11

TYPE : 430

IMPELLER : Enclosed

R. P. M. : 1750

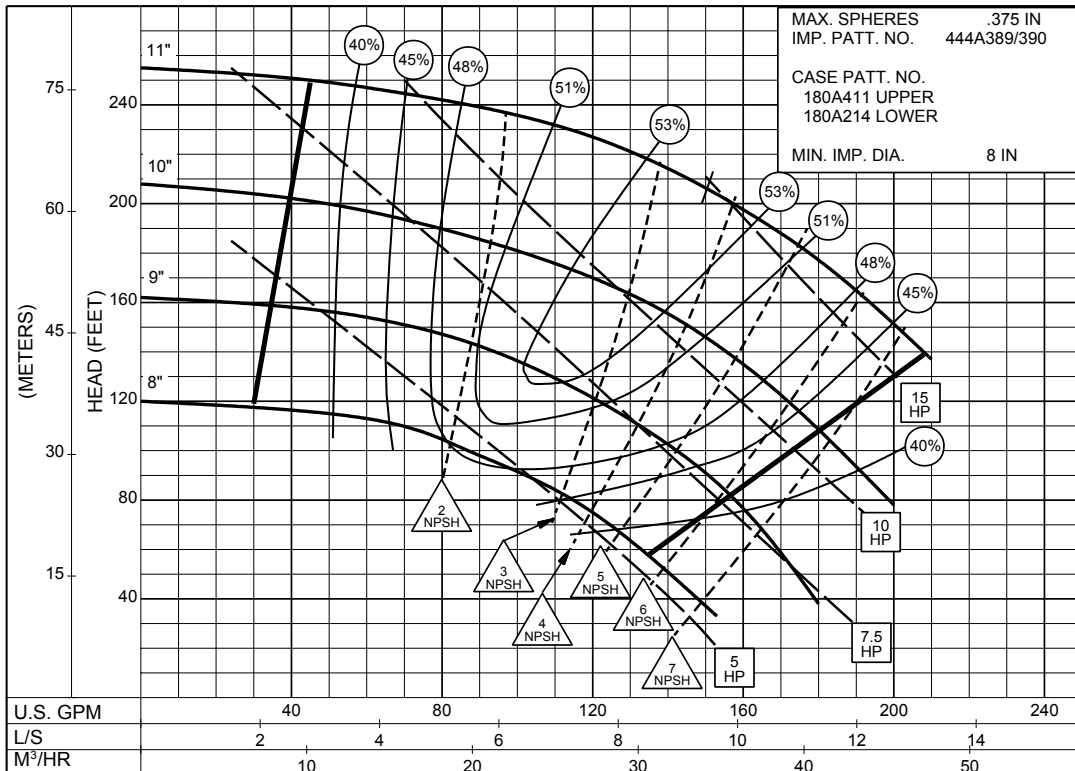

PC-158292

1750
R.P.M