

**AURORA® MODELS**  
**471-481-483-485-491-492**

ENGINEERING SPECIFICATIONS  
CENTRIFUGAL FIRE PUMPS

Section **910** Page **61**

Date **April 2018**

Supersedes Section 910 Page 61  
Dated March 2013

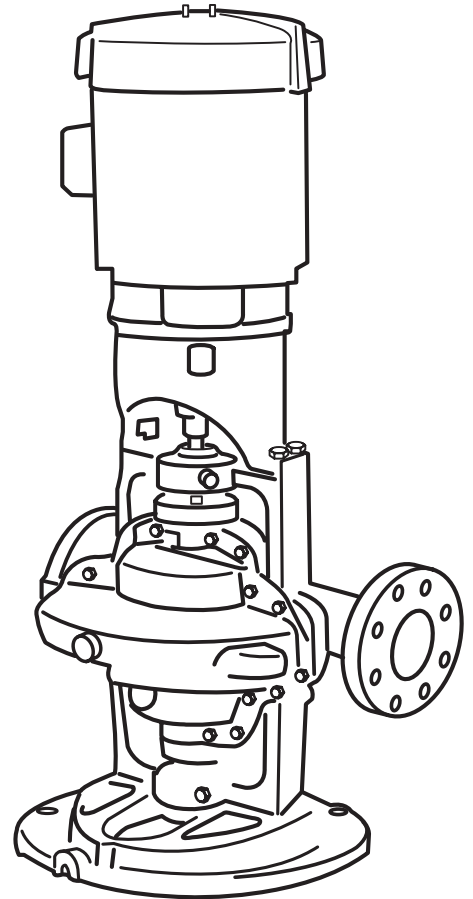
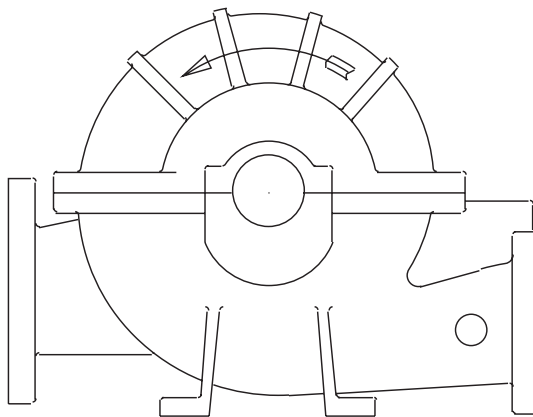
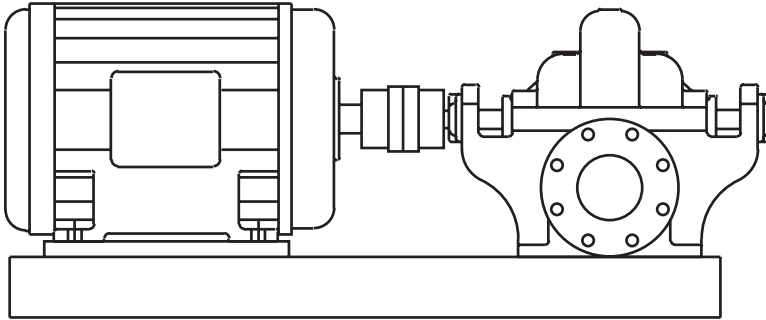

Furnish and install where shown on plans \_\_\_\_\_ Aurora Fire Pump System(s) complete with pump, driver, controller and accessories. The pumping unit shall be listed by Underwriters' Laboratories, Inc. and/or shall be fully approved by the Associated Factory Mutual Fire Insurance Companies, where applicable. The pumping unit shall meet all requirements of the National Fire Protection Association Pamphlet No.20. The Fire Pump shall be designed to deliver \_\_\_\_\_ G.P.M. when operating at \_\_\_\_\_ PSIG. The pump shall also deliver not less than 150% of rated capacity at a pressure not less than 65% of rated pressure. The shut off pressure shall not exceed 140% of rated pressure. Suction pressure is \_\_\_\_\_ PSIG. The pump shall operate at a maximum synchronous speed of \_\_\_\_\_ R.P.M.

The Fire Pump shall be (one of the following):

(A) AURORA MODEL 471/481 - 491/492 HORIZONTAL BASE MOUNTED size \_\_\_\_\_-471/481 - 491/492-\_\_\_\_\_ horizontal split case, bronze fitted,

SINGLE STAGE, double suction centrifugal pump.

(B) AURORA MODEL 485 HORIZONTAL BASE MOUNTED size \_\_\_\_\_-485-\_\_\_\_\_ horizontal split case, bronze fitted, TWO STAGE, single suction, centrifugal pump.

The driver shall be a horizontal, foot mounted, open drip-proof (or T.E.F.C.), ball bearing type, AC, induction, squirrel cage motor: wound for \_\_\_\_\_ volts, 3 phase, 60 (50) Hertz. The motor shall be of such capacity that 115% of the full-load ampere rating shall not be exceeded at any condition of pump load. Locked rotor current shall not exceed the values specified in NFPA Pamphlet No.20.

**AURORA® MODELS**  
**471-481-483-485-491-492**

ENGINEERING SPECIFICATIONS

CENTRIFUGAL FIRE PUMPS

Pump and motor shall be mounted on a common baseplate of steel (or optional with drip rim). Pump and motor shall be checked for alignment after the pump base has been installed and grouted in place.

C. AURORA MODEL 483 VERTICAL BASE MOUNTED size \_\_\_\_-483-\_\_\_\_ vertical splitcase, vertical mounted, bronze fitted, SINGLE STAGE double suction, centrifugal pump.

The driver shall be a vertical, open drip-proof (or T.E.F.C.), ball bearing type, AC, induction, squirrel cage "P" face motor: wound for \_\_\_\_ volts, 3 phase, 60 (50) Hertz. The motor shall be of such capacity that 115% of the full-load ampere rating shall not be exceeded at any condition of pump load. Locked rotor current shall not exceed the values specified in NFPA Pamphlet No.20.

The mounting feet of the pump shall be machined perpendicular to the shaft. The pump shall be bolted to an extra heavy cast iron drip rim ring base. The top of the pump shall be machined to receive the motor mounting bracket. The mounting bracket shall be machined with registered fits to align pump and motor.

Casings shall be of cast iron \_\_\_\_ ductile iron \_\_\_\_ having a minimum tensile strength of 35,000 P.S.I. Bearing housing supports, and suction and discharge flanges shall be integrally cast with the lower half of the casing. Removal of the upper half of the casing must allow the rotating element to be removed without disconnecting the suction and discharge flanges.

Impellers shall be of the enclosed type and shall be of vacuum cast bronze \_\_\_\_ stainless steel \_\_\_\_\_. Impellers shall be dynamically balanced, keyed to the shaft, and \_\_\_\_ held in place with threaded shaft sleeves.

The pump shaft shall be made of SAE 1045 Steel or equal, accurately machined to give a true running rotating element. Shaft shall be protected by bronze sleeves which are key locked and threaded so that the sleeves tighten with the rotation of the shaft. An o-ring shall seal between the impeller hub and the shaft sleeve to protect the pump shaft.

Pump shall be equipped with renewable bronze casing rings so designed that hydraulic pressure will seat them against a shoulder in the pump case around the full periphery of the wearing ring. The wearing rings will be locked by dowelling to prevent rotation. The rotating element uses heavy duty grease lubricated ball bearings and shall be equipped with water slingers. Bearing housings shall be so designed to flush lubricant through the bearing.

All pumps \_\_\_\_ where the suction pressure is expected to average 40 P.S.I. or below, shall be provided with a lantern ring connected to the pressure side of the pump \_\_\_\_ by a cored passage in the parting flange of the pump \_\_\_\_ through external flush lines. Stuffing boxes shall be equipped with split stainless steel packing glands designed for easy removal for packing inspection and maintenance.

The fire pump unit shall include the following accessories, as required by NFPA standards (depending on the conditions under which the pumps are to be installed).

- |  |               |
|--|---------------|
| 1. Flow metering device                                  | <u>  X  </u>  |
| 2. Eccentric tapered suction reducer                     | <u>  X  </u>  |
| 3. Concentric tapered discharge increaser                | <u>  X  </u>  |
| 4. Discharge tee   | <u>      </u> |
| 5. Base elbow  | <u>      </u> |
| 6. Hose valves   | <u>  X  </u>  |
| 7. Caps and chains                                       | <u>  X  </u>  |
| 8. Hose valve header                                     | <u>  X  </u>  |
| 9. Blind flange  | <u>      </u> |
| 10. Pressure gauges                                      | <u>  X  </u>  |
| 11. Main relief valve (mandatory for engine drives)      | <u>  X  </u>  |
| 12. Circulation relief valve                             | <u>  X  </u>  |
| 13. Relief cone - enclosed (mandatory for engine drives) | <u>  X  </u>  |
| 14. Automatic air release valve                          | <u>  X  </u>  |
| 15. Splash shield (electric drive only)                  | <u>      </u> |
| 16. Balldrip valve                                       | <u>  X  </u>  |
| 17. Coupling guard                                       | <u>  X  </u>  |

**AURORA® MODELS**  
**471-481-483-485-491-492**  
**ENGINEERING SPECIFICATIONS**  
**CENTRIFUGAL FIRE PUMPS**

The Fire Pump motor control shall be U.L. Listed and/or F.M. Approved, where applicable. It shall be completely assembled, wired and tested by the control manufacturer before shipment from the factory, and shall be labeled "Fire Pump Controller." The controller shall be located as close as practical and within sight of the motor. The controller shall be so located or protected that it will not be injured by water escaping from the pump or connections. The controller shall be of the combined manual and automatic, (across-the-line) (primary resistor) (partwind) (limited service) (wye delta) type, and shall be complete with:

1. Disconnect switch - externally operable, quick-break type.
2. Circuit breaker - time delay type with trips in all phases set for 300% of the motor full-load current. The interrupting capacity of circuit breaker shall be \_\_\_\_\_ asymmetrical amperes.
3. Motor starter - across-the-line type capable of being energized automatically through the pressure switch or manually by means of an externally operable handle.
4. Pressure switch set to cut in at \_\_\_\_\_ p.s.i.g. and out at \_\_\_\_\_ p.s.i.g.
5. Running period timer - set to keep motor in operation, when started automatically, for a minimum period of one minute for each 10 HP motor rating, but not to exceed 7 minutes.
6. Pilot lamp - to indicate circuit breaker closed and power available.
7. Ammeter test link and voltmeter test studs.
8. Alarm relay - to energize an audible or visible alarm through an independent source of power to indicate circuit breaker open or power failure.
9. Manual selection station - a two position station shall be provided on the enclosure marked "Automatic" and "Non-automatic."
10. Means shall be provided on the Controller to operate an alarm signal continuously while the pump is running.

Control equipment shall meet all requirements of NFPA No.20.

**ENGINE DRIVE**

The Fire Pump shall be driven by a U.L. Listed and F.M. Approved diesel engine. The engine shall conform to the requirements of NFPA Pamphlet No.20 and be approved for Fire Pump use. The rated speed shall not exceed \_\_\_\_\_ RPM and shall develop \_\_\_\_\_ H.P. to drive the pump. Reserve H.P. shall be as stipulated in Pamphlet No.20 when the unit is operating at \_\_\_\_\_ ft. above sea level in an ambient temperature not greater than \_\_\_\_\_ degrees F. The engine shall be of the self-contained open type mounted on a suitable base with the following minimum accessories, plus any others that may be necessary by local requirements.

- |   |              |
|---|--------------|
| 1. Dual battery set sized to NFPA Pamphlet No.20 requirements with rack and cables  | <u>  X  </u> |
| 2. Dual battery charger of proper type for batteries used (included in U.L. Listed/F.M. Approved controller)  | <u>  X  </u> |
| 3. Electric starter with suitable generator and voltage regulator   | <u>  X  </u> |
| 4. Engine water pump  | <u>  X  </u> |
| 5. Heat exchanger cooling system  | <u>  X  </u> |
| 6. Water cooled or ceramic blanketed exhaust manifold   | <u>  X  </u> |
| 7. Lubricating oil pump and filter  | <u>  X  </u> |
| 8. Speed governor   | <u>  X  </u> |
| 9. Fuel injection system  | <u>  X  </u> |
| 10. Air cleaner   | <u>  X  </u> |
| 11. Driveshaft and guard  | <u>  X  </u> |
| 12. Fuel Pump   | <u>  X  </u> |
| 13. Engine Jacket Pre-heater  | <u>  X  </u> |
| 14. Oil Emersion Heater   | <u>  X  </u> |
| 15. Proper instrument panel complete with engine run warning light, water temperature gauge, oil pressure gauge, ammeter, totalizing type tachometer and hour meter | <u>  X  </u> |
| 16. Commercial Grade Muffler  | <u>  X  </u> |
| 17. Cooling water line for the engine heat exchanger assembly   | <u>  X  </u> |
| 18. Flexible exhaust connectors   | <u>  X  </u> |

All engine wiring for automatic operation shall terminate in a proper junction box to permit field connection to a separate control panel.

**AURORA® MODELS**  
**471-481-483-485-491-492**

**ENGINEERING SPECIFICATIONS**  
**CENTRIFUGAL FIRE PUMPS**

**FUEL SYSTEM**

A suitable fuel system for the diesel engine shall be furnished. It must be in accordance with NFPA Pamphlet No.20, and shall include a \_\_\_\_\_gallon above surface storage tank. Flexible fuel connectors, emergency vent and fill cap shall be included.

**AUTOMATIC ENGINE CONTROL PANEL**

The automatic engine control panel shall be approved for fire pump service and shall meet the requirements of NFPA Pamphlet No. 20. The panel shall be of the floor-mounted type, and enclosed in a moisture and dust tight housing. A combination manual and automatic type controller with "Manual-Off-Automatic" selector switch shall be provided also, a 115 volt single phase power failure relay or a pressure switch, which will (when the system drops to \_\_\_\_\_psig) activate all electrical circuits to automatically start the engine.

Should the engine fail to start after the required cranking cycles, the controller shall disconnect the starting circuit and activate an alarm system using lights and buzzer or bell. "Low oil pressure" and "high jacket-water temperature" shall also be indicated by a suitable alarm system. The engine shall not shut down if either of these conditions occurs during an operating cycle.

The engine shall be started automatically by the controller at least once a week and operate a minimum of 30 minutes. An appropriate timing arrangement shall determine the day and hour of this test.

Starting the engine by a fire alarm relay, deluge valve relay, or remote push-button station shall be included in the controller circuit.

In the event the pump, engine and control are in an unattended area, a remote alarm panel shall be furnished as per NFPA Pamphlet No.20.

**TESTS**

The pump and electric motor (or engine) shall be thoroughly shop-tested by the respective manufacturers as required by NFPA Pamphlet No.20. The control panel shall also be tested as a unit. All such tests shall be conducted prior to shipment.

The pump, driver, controller and all accessories shall be purchased under a unit contract. The pump shall be given a complete performance test with POSITIVE SUCTION PRESSURE. A certified performance curve shall be prepared and submitted. Pumps shall also be hydrostatically tested to 1.5 times the maximum working pressure, but in no case less than 250 lbs. per sq. inch.

The pump manufacturer shall assume unit responsibility and shall provide the services a factory trained representative to supervise and/or be available to conduct final field acceptance tests.