

SPLIT COUPLED IN-LINE PUMPS

Standard Features

- Stainless steel shaft
- Dynamically balanced stainless steel impeller
- 303 stainless steel mechanical seal with buna-n, ceramic and carbon parts
- Flush Line

Optional Features

- Pump base
 - High temperature mechanical seal
 - Outside balanced seal
 - Certified performance testing over the full operating range of the pump
 - Abrasive separator with sight flow indicator
 - Epoxy coating in casing internal surface to reduce surface roughness of hydraulic passages
 - Different flange drilling options
- *Motors are available with shaft grounding ring and insulated NDE bearings

Forward Thinking Designs

- Shared hydraulics with 3800 series End Suction
- More durable construction than leading competition
 - Stainless steel impeller and casing wear ring
- Unique jacking mechanisms for seal servicing
 - Needs no special tools
- Standard C face motor improves lead time compared to previous generations
- Ductile iron casings provide higher working pressures
- Standard footed motors
- Efficiencies meet DOE 2020 energy regulations
- Meets federal low lead legislation for potable water



1200 RPM Curve

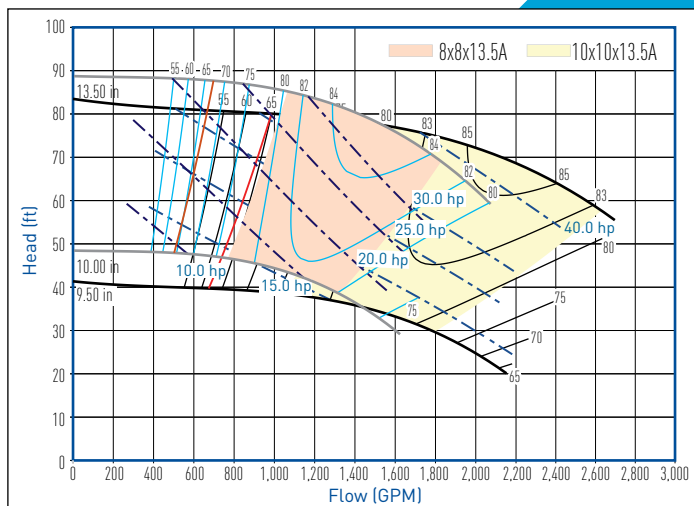

1800 RPM Curve

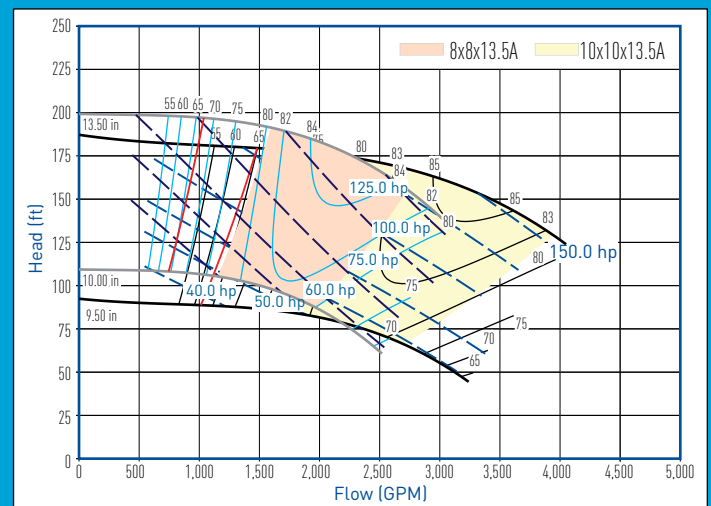

Material of Construction

| Pump Part | Stainless Impeller Fitted |
|-----------------------|------------------------------------|
| Casing | Ductile Iron ASTM A536 |
| Impeller | Stainless Steel ASTM A743 Type 316 |
| Shaft | Stainless Steel ASTM A582 Type 416 |
| Bushing | Carbon Graphite Matrix |
| Case Wearing Rings | Stainless Steel ASTM A582 Type 416 |
| Bracket | Cast Iron ASTM A48 |
| Mechanical Seal (STD) | Type 21 Carbon/Ceramic/Buna/SS |

Limitations

| Maximum Limitation Based On Standard Materials and Pumping Clear Water | |
|--|-----------------------------|
| Temperature °F | Standard 225 / Optional 275 |
| Maximum Working Pressure PSI* | 250 PSI |

*Max pressure dependent on seal and flange selection

| Pump Size | Dimensions | | | | |
|-------------|--------------|--------------|--------------|--------------|----------------------------|
| | X (mm) | DC (mm) | DE (mm) | YY (mm) | VD (mm) without spool base |
| 8x8x13.5A | 21.50" (546) | 9.93" (252) | 13.74" (349) | 20.50" (521) | 11.46" (291) |
| 10x10x13.5A | 23.00" (584) | 10.52" (267) | 15.67" (398) | 24.50" (622) | 12.38" (314) |

Dimensional Data

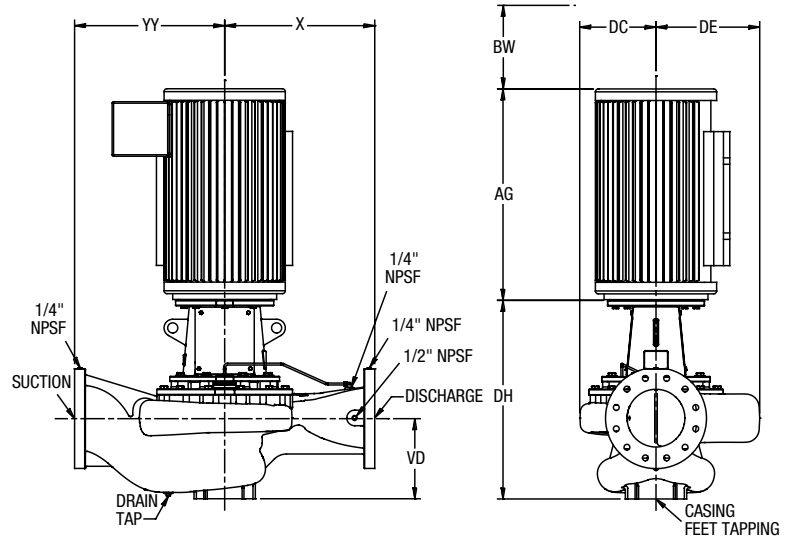

| Pump Size | Available Frame Range | DH + AG [Min/Max] (mm) without spool base | Approximate Weight [Min/Max] (kg) without spool base and motor |
|-------------|-----------------------|---|--|
| 8x8x13.5A | 250TC to 440TC | 53.8" (1367) / 82.84" (2104) | 586 lbs. (266) / 643 lbs. (292) |
| 10x10x13.5A | 250TC to 440TC | 54.56" (1386) / 83.59" (2123) | 725 lbs. (329) / 783 lbs. (355) |

Performance Data - 382 Split Coupled Range (60 Hz)

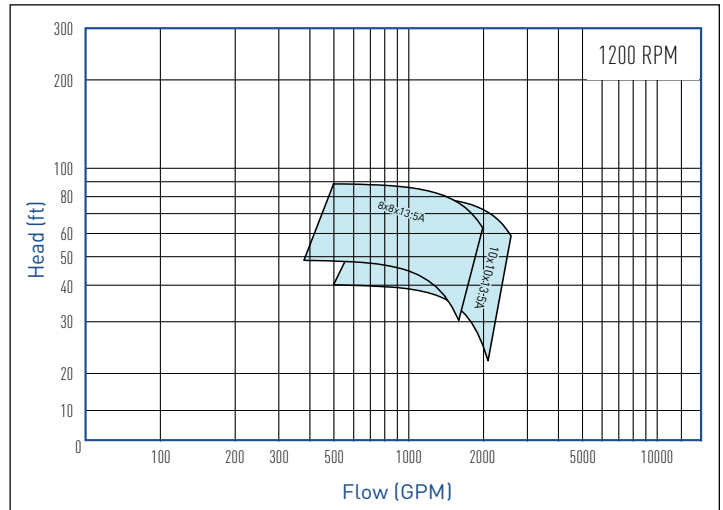
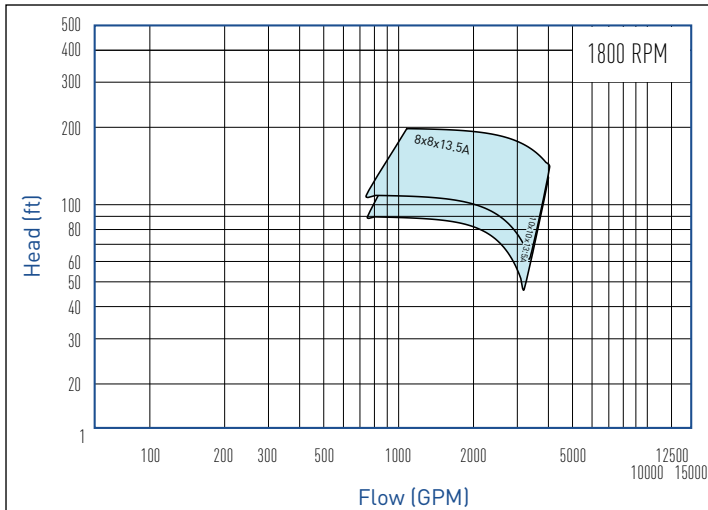

For more information, contact your authorized Pentair Aurora Distributor.



800 Airport Road | North Aurora | Illinois 60542 | www.aurorapump.com

Because we are continuously improving our products and services, Pentair reserves the right to change specifications without prior notice.
A-02-1076 06/07/18 ©2018 Pentair plc. All Rights Reserved.